

IOM manual

tapflo®

CTX High Performance Centrifugal Pumps

Original instruction
2020 | 1



Read this instruction manual carefully,
before you install and operate the pump.



CTX I

CTX I 40-165
CTX I 50-145
CTX I 50-200
CTX I 65-175
CTX I 65-230
CTX I 65-240
CTX I 80-205
CTX I 80-212
CTX I 80-260
CTX I 100-230

CTX H

CTX H 40-165
CTX H 50-145
CTX H 50-200
CTX H 65-175
CTX H 65-230
CTX H 65-240
CTX H 80-205
CTX H 80-212
CTX H 80-260
CTX H 100-230



» All about your flow

www.tapflo.com

CONTENTS

EC DECLARATION OF CONFORMITY 01/EC/CTX/2020	4
0. GENERAL	5
0.1. Introduction.....	5
0.2. Warning symbols	5
0.3. Qualification and training of personnel	5
1. INSTALLATION	6
1.1. Operation principle	6
1.2. Receiving inspection.....	6
1.3. Lifting and transportation	6
1.4. Storage.....	7
1.5. Foundation	7
1.6. Environment	7
1.7. Suction and discharge piping	7
1.7.1. Connection of discharge pipe	7
1.7.2. Connection of suction pipe	8
1.8. Health and safety	8
1.8.1. Protection	8
1.8.2. Electrical safety	9
1.8.3. Chemical hazard	9
1.8.4. Dry running	9
1.8.5. Noise level	9
1.8.6. Temperature hazards.....	9
1.8.7. Rotating parts.....	9
1.8.8. Cleaning and disinfection.....	9
1.9. Example of installation.....	10
1.10. Instruments.....	10
1.10.1. Electric power	11
1.10.2. Optional instruments.....	11
1.10.3. Thermometer.....	11
1.11. Motor connection	11
1.12. Motor standard	12
2. OPERATION	13
2.1. Start-up.....	13
2.1.1. Starting the pump.....	13
2.1.2. Restarting after power shut-off.....	13
2.2. Stopping the pump.....	14
2.3. Cleaning and disinfection.....	14
2.3.1. Cleaning procedure.....	14
2.4. Residual risks	15
2.5. Disposal after expiration of the expected lifetime	15

CONTENTS

2.6.	Waste of electrical and electronic equipment (WEEE) directive	15
2.7.	Actions in emergency	15
3.	MAINTENANCE	16
3.1.	Inspections.....	16
3.2.	Location of faults	16
3.3.	Disassembly of the pump.....	17
3.3.1.	Disassembly procedure.....	17
3.4.	Assembly of the pump.....	20
3.4.1.	Test run	23
4.	OPTIONS	24
4.1.	Motor shroud – M/N.....	24
5.	SPARE PARTS	25
5.1.	Spare parts drawing.....	25
5.2.	Spare parts list.....	26
5.3.	Recommended spare parts.....	26
5.4.	How to order parts.....	26
6.	DATA	27
6.1.	Pump code	27
6.2.	Dimensions	28
6.3.	Materials, data and limits.....	32
6.4.	Mounting torques and dimensions of screws/nuts	33
6.5.	Performance curves	34
6.6.	Permitted loads on inlet and outlet	35
7.	WARRANTY	36
7.1.	Returning parts	36
7.2.	Warranty	36
7.3.	Warranty form.....	38

EC DECLARATION OF CONFORMITY 01/EC/CTX/2020

Series:

CTX...

Serial numbers:

From 2001 - ...

Manufactured by:

Tapflo AB

Filaregatan 4

442 34 Kungälv, Sweden

This declaration of conformity is issued under the sole responsibility of the manufacturer.

Object of declaration: **SINGLE STAGE CENTRIFUGAL PUMPS**

The object of the declaration described above is in conformity with the relevant Union harmonisation legislation:

- Directive 2006/42/EC of European Parliament and of the Council of 17 May 2006 on machinery, amending Directive 95/16/EC;
- Directive 2014/35/UE of the European Parliament and of the Council of 14 February 2014 on harmonization of the laws of Member States relating to electrical equipment designed for use within certain voltage limits;

Mr Michał Śmigiel is authorized to compile the technical file.

Tapflo Sp. z o.o.
ul. Czatkowska 4b
83-110 Tczew

Signed for and on behalf of Tapflo AB:



Håkan Ekstrand

Managing director

Tapflo AB, 02.02.2020

0. GENERAL

0. GENERAL

0.1. Introduction

The CTX pumps are open impeller single stage centrifugal pumps. They are manufactured in high finish and mechanical strong material stainless steel AISI 304/316L. The pump range meets the demands from a variety of today's industries.

The industrial series CTX I is designed with sand blasted pump casing. A variety of connection types, mechanical seal options and other executions are available to satisfy most type of industrial duties.

The hygienic series CTX H is supplied with electro polished internals. This series is specially dedicated for hygienic duties in food, beverage and pharmaceutical industries, where clean- and drain-ability are important factors.

With proper attention to maintenance, CTX pumps will give efficient and trouble free operation. This instruction manual will familiarise operators with detailed information about installing, operating and maintaining the pump.

0.2. Warning symbols

The following warning symbols are present in this instruction manual. This is what they say:



This symbol stands next to all safety instructions in this instruction manual where danger to life and limb may occur. Observe these instructions and proceed with utmost caution in these situations. Inform also other users of all safety instructions. In addition to the instructions in this instruction manual, the general safety and accident prevention regulations must be observed.



This signal stands at points in this instruction manual of particular importance for compliance with regulations and directives, for correct work flow and for the prevention of damage to and destruction of the pump.



This symbol signals possible danger caused by the presence of electric fields or live wires.

0.3. Qualification and training of personnel



The personnel in charge of installation, operation and maintenance of the pumps we produce must be qualified to carry out the operations described in this manual. Tapflo shall not be held responsible for the training level of personnel and for the fact that they are not fully aware of the contents of this manual.

1. INSTALLATION

1. INSTALLATION

1.1. Operation principle

In order to operate the pump, the casing has to be filled with liquid before start-up. The liquid enters the pump casing axially to the shaft. The rotating impeller generates a centrifugal force accelerating the liquid through the pump casing and into the discharge piping.

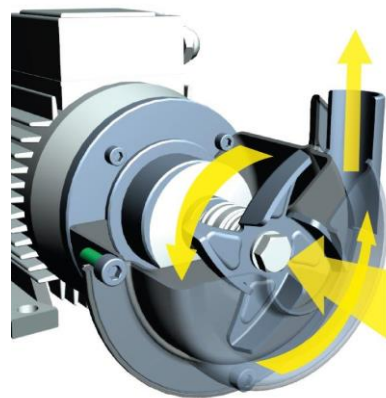

1.2. Receiving inspection

Although precaution is taken by us when packing and shipping, we urge you to carefully check the shipment on receipt. Make sure that all parts and accessories listed on the packing list are accounted for. Immediately report any damage or shortage to the transport company and to us.

1.3. Lifting and transportation

Before handling the pump check the weight of the pump (see chapter 6. Data). Refer to Your local standards on how to handle the pump. If the weight is excessive to transport by hand it must be lifted using slings and a suitable lifting device e.g. a crane or forklift.

Always use at least two slings and make sure they are secured in such a way to prevent the pump from slipping and that the pump unit is hanging straight.

Never lift the pump with only one sling. Incorrect lifting can cause serious injury and/or damage to the pump.

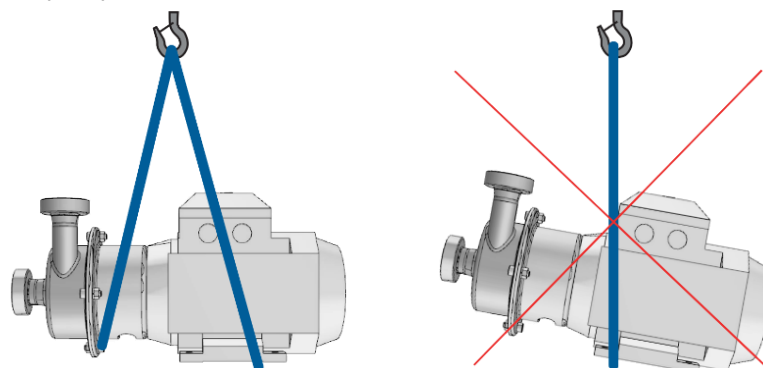

Never lift the pump under pressure.

Be careful that nobody passes under the pump when lifted.

Never try to lift the pump by the connections or hoses attached to the pump.

1. INSTALLATION

1.4. Storage



If the equipment is to be stored prior to installation, place it in a clean location. Do not remove the protective covers from the suction and discharge which have been fastened to keep pump internals free of debris. Clean the pump thoroughly before installation.

When in storage, turn the shaft by hand at least once per month. The pump-motor unit should always be stored indoor in dry, vibration and dust free conditions.

1.5. Foundation



The pump-motor unit must stand on and be fixed to a sufficiently rigid structure that can support the entire perimeter on which the unit stands. The foundation on a firm bottom is the most satisfactory. Once the pump is in position, adjust level with metal shims between the feet and the surface on which it stands. Check that the feet of the pump motor unit stand well on each of them. The surface on which the foundation stands must be flat and horizontal. If the unit is fitted on a steel structure, make sure that it is supported so that the feet do not warp. In any case, it is advisable to fit some anti-vibration rubber pieces between the pump and the brickwork. The motor needs an additional stand as its level is higher than that of the pump casing. As an option the pump can be ordered with feet for the motor. For close-coupled type, pump motor alignment is not required.

1.6. Environment



- There should be enough space in the vicinity of the pump in order to operate, maintain and repair it.
- The area in which the pump is operated, must be sufficiently ventilated. Excessive temperature, humidity or dirt may affect the pump operation.
- Behind the cooling fan of the motor there must be sufficient room for the hot air to escape the motor.

1.7. Suction and discharge piping



A pump is generally part of a piping system that can include a number of components such as valves, fittings, filters, expansion joints, instruments, etc. The way the piping is arranged and the positioning of the components has a great influence on the operation and the lifetime of the pump. The pump cannot be used as a support for the components connected to it.

The flow of liquid from the pump must be as even as possible. It is advisable to avoid any tight bends or drastic reductions of diameters that may cause flow resistance in the installation. In case of diameter reduction, it is advisable to use appropriate conical reductions (possibly eccentric on suction side and concentric on discharge side) at changes of diameter and at a minimum distance from pump connections of five diameters of the pipeline.

1.7.1. Connection of discharge pipe



A check-valve and a shut-off/regulation valve are normally fitted on the discharge side.

The check-valve protects the pump from any backflow. The shut-off/regulation valve cuts off the pump from the line and adjusts the output. Never adjust flow rate using the valve on the suction pipe.

1. INSTALLATION

1.7.2. Connection of suction pipe



The suction piping is very important for the correct operation of the pump assembly. It must be as short and as direct as possible. If a longer suction line is unavoidable, the diameter should be large enough, i.e. at least as the inlet connection on the pump, to ensure less flow resistance. In any case, suction must be carried out properly avoiding any air locks.

The CTX pumps are single-stage centrifugal pumps, thus not self-priming. It will therefore always be necessary to install a bottom valve in all cases when the static height of the liquid is lower than the suction height of the pump. It is also crucial that the whole suction line is filled with liquid prior to starting the pump. The suction piping must be air tight. Critical points in these terms are also the seals between flanges and the seals of the valve stems. Even some small air let into the suction line cause serious operating problems that can make the pump stop. It is recommended to use check-valve in the suction line to avoid siphoning when the pump stops.

1.8. Health and safety

The pump must be installed according to local and national safety rules.



The pumps are constructed for particular applications. Do not use the pump on applications different from that for which it was sold without consulting us to ascertain its suitability.

1.8.1. Protection



In the interest of health and safety it is essential to wear protective clothing and safety goggles when operating, and/or working in the vicinity of Tapflo pumps.

1. INSTALLATION

1.8.2. Electrical safety



Do not carry out any maintenance or/and operation on the pump while it is running or before it has been disconnected from the power supply. Avoid any danger caused by electric power (for details see current regulations in force). Check that electrical specifications on the data plate are equivalent to the power supply to which it will be connected.

1.8.3. Chemical hazard



Whenever the pump is to be used for pumping a different liquid, it is essential to clean the pump beforehand in order to avoid any possible reaction between the two products.

1.8.4. Dry running



Do not start nor carry out running tests before filling the pump with liquid. Always avoid dry operation of the pump. Start the pump when it is completely filled and with the valve on the discharge side almost completely closed.

1.8.5. Noise level



CTX pumps, including the motor, in normal operating conditions produce a sound level below 80 dB(A). The major sources of noise are: liquid turbulence in the installation, cavitation or any other abnormal operation that is independent from the pump construction nor the pump manufacturer. The user must provide suitable protective means if the sources of noise could produce a harmful noise level for operators and for the environment (in compliance with current local regulations).

1.8.6. Temperature hazards



Raised temperature can cause damage on the pump and/or piping and may also be hazardous for personnel in the vicinity of the pump/piping. The hot or cold parts of the machine must be protected to avoid accidental contacts.

1.8.7. Rotating parts



Do not tamper with the protection of the rotating parts, do not touch or approach rotating parts in movement.

1.8.8. Cleaning and disinfection



Cleaning and disinfection of the pump system is of greatest importance when the pump is used in a food process installation. Use of a pump system that is NOT cleaned or disinfected can cause contamination of the product.

1. INSTALLATION

1.9. Example of installation

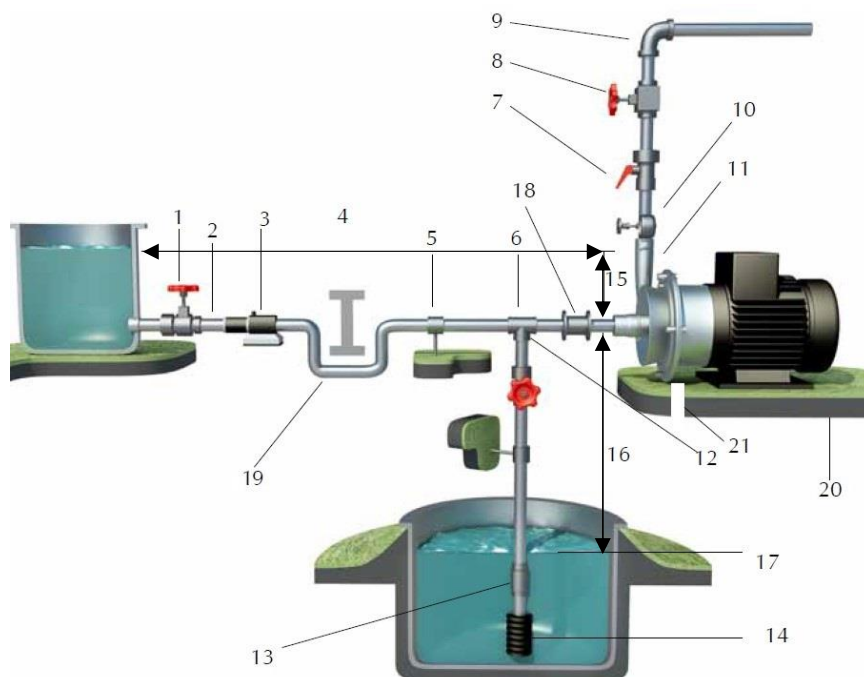

- 1) YES: Gate valve (may also be near pump in case of long piping)
- 2) With positive head: tilt of piping towards pump
- 3) YES: line strainer if particles are present
- 4) NO: air pockets – the circuit must be short and straight
- 5) YES: pipe fastening
- 6) Suction line as short and direct as possible
- 7) YES: attachment for gauge or safety pressure switch
- 8) YES: adjusting gate valve on outlet
- 9) Bends placed after valves and instruments not closer to the pump inlet than five times the piping diameter
- 10) YES: attachment for gauge or safety pressure switch
- 11) NO: elbow joints (and other parts) on the pump (discharge and suction lines)
- 12) With negative suction lift: tilt of piping towards suction tank
- 13) YES: check valve (with negative suction lift)
- 14) YES: strainer if particles are present
- 15) Suction head varies according to flow in order to prevent windage
- 16) Suction head
- 17) Immersion depth
- 18) YES: expansion joint (indispensable with long pipes or hot liquids) and/or anti-vibration facility during discharge and suction; anchored near to pump
- 19) YES: overcoming obstacles at lower depths
- 20) Fix the pump by the fixing holes provided: the supports must be level
- 21) YES: drainage channel around base

1.10. Instruments



In order to ensure a proper control of the performance and the conditions of the installed pump, we recommend using the following instruments:

- a pressure-vacuum gauge on the suction piping;
- a pressure gauge on the discharge piping.

1. INSTALLATION

The pressure intakes must be made of straight pieces of piping at a distance of minimum five diameters from the pump inlets. The pressure gauge on discharge must always be fitted between the pump and the shut-off / regulation valve. The output can be read on the pressure gauge, transformed into meters and then compared with the typical curves.

1.10.1. Electric power

The electric power absorbed by the motor can be measured by means of a wattmeter or an amp gauge.

1.10.2. Optional instruments

The optional instruments can indicate if pump is working in an abnormal way. The abnormal conditions can be caused by: accidentally closed valves, lack of pumped liquid, overloads, etc.

1.10.3. Thermometer

If the temperature of the pumped liquid is a critical parameter, provide the installation with a thermometer (preferably on the suction side).

1.11. Motor connection



An expert electrician must always carry out the electrical connection. Compare the power supply with the data plate specifications and then choose a suitable connection. The type of connection is stated on the motor data plate and can be Y (star) or D (Delta), according to the power supply of the motor (see figure below).

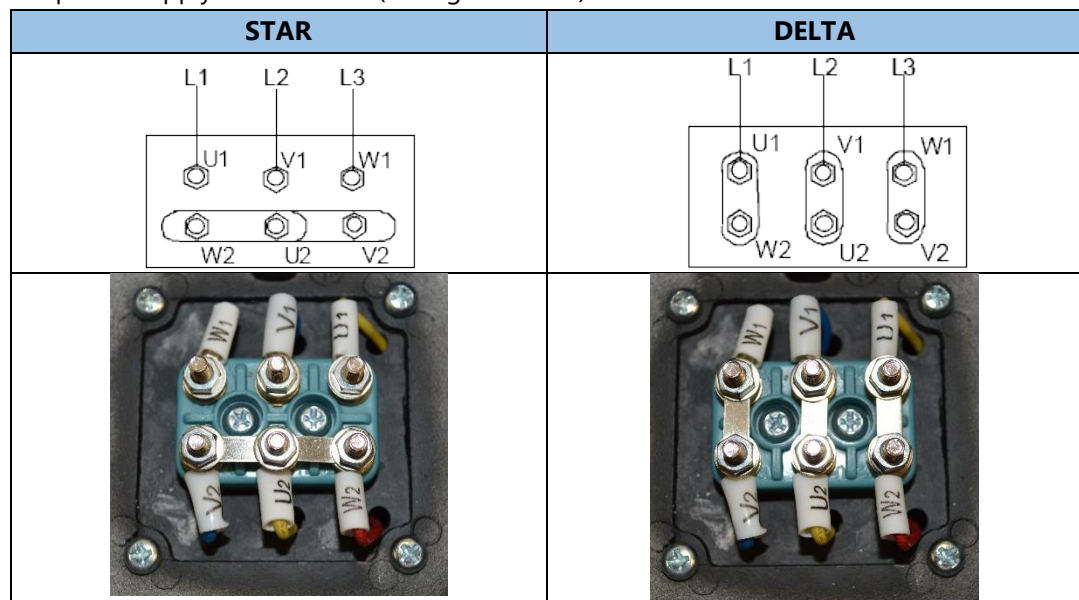

Follow the connection standard used in the plant. In no case connect the electrical motor directly to supply network but use a suitable electric switchboard equipped with a knife switch and suitable safety devices (e.g. motor breaker switches) in the power circuit. Safety devices against overloads must also protect the motors. Make sure that the motor has suitable grounding and that it has been connected properly.

1. INSTALLATION

1.12. Motor standard

As a standard Tapflo CTX pump are equipped with motors of the following parameters:



- International Mounting Arrangement – **B35**
- Number of poles / Rotation speed [rpm] – **2**
- **Non ATEX**
- Protection grade – **IP55**
- Voltage – **3 phase**
- **PTC protection**

Motor power	IEC size	RPM	Voltage	Frequency
1.5 kW	90S	2920	Δ230 / Y400	50 Hz
		3500	Δ280 / Y480	60 Hz
2.2 kW	90L	2920	Δ230 / Y400	50 Hz
		3500	Δ280 / Y480	60 Hz
3.0 kW	100L	2910	Δ230 / Y400	50 Hz
		3500	Δ280 / Y480	60 Hz
4.0 kW	112M	2910	Δ400 / Y690	50 Hz
		3500	Δ480 / Y830	60 Hz
5.5 kW	132S	2930	Δ400 / Y690	50 Hz
		3500	Δ480 / Y830	60 Hz
7.5 kW	132S	2930	Δ400 / Y690	50 Hz
		3520	Δ480 / Y830	60 Hz
11 kW	160M	2950	Δ400 / Y690	50 Hz
		3540	Δ480 / Y830	60 Hz
15 kW	160M	2950	Δ400 / Y690	50 Hz
		3550	Δ480 / Y830	60 Hz
18.5 kW	160L	2960	Δ400 / Y690	50 Hz
		3550	Δ480 / Y830	60 Hz
22 kW	180M	2960	Δ400 / Y690	50 Hz
		3550	Δ480 / Y830	60 Hz
30 kW	200L	2970	Δ400 / Y690	50 Hz
		3550	Δ480 / Y830	60 Hz
37 kW	200L	2970	Δ400 / Y690	50 Hz
		3560	Δ480 / Y830	60 Hz
45 kW	225M	2970	Δ400 / Y690	50 Hz
		3580	Δ480 / Y830	60 Hz

2. OPERATION

2. OPERATION

2.1. Start-up

- Check manually that the motor is free to turn, moving the motor cooling fan.
- Make sure that the piping is not clogged and is free from residues or foreign objects. Make sure that the liquid flows regularly into the pump.
-  ➤ The pump and piping connected to it, at least the suction pipe, must be full of liquid. Any air or gas must be carefully released. In case of suction with negative head, fill the suction piping and check how the bottom valve works. It must guarantee that the liquid must not flow back, therefore emptying the suction pipe with consequent disconnection of the pump.
- The suction shut-off valve (if any) must be completely open.
- The shut-off / regulation valve on the discharge side must be 75% closed.
-  ➤ The motor must turn in the same direction as the arrow shown on the pump. The direction of rotation is always clockwise looking at the pump from the motor side; check by starting briefly, then looking at the direction of rotation of the motor fan through the fan lid. If it is wrong, the motor must be stopped immediately. Change the connection to the terminals of the electric motor (chapter 1.11 "Motor connection") and repeat the procedure described above.
-  ➤ Any auxiliary connections must all be connected.

2.1.1. Starting the pump



The CTX pump must be started with almost closed discharge valve. Start the electric motor and open the discharge shut-off / regulation valve gradually until the desired output has been reached. The pump must not run more than two or three minutes with closed discharge. Longer operation in these conditions can seriously damage the pump.



If the pressure shown on the pressure gauge on the discharge piping does not increase, turn off the pump immediately and release pressure carefully. Repeat the connection procedure.



If there are changes of flow rate, head, density, temperature or viscosity of the liquid, stop the pump and get in touch with our technical service.

2.1.2. Restarting after power shut-off



In case of accidental stopping, make sure that the non-return valve has prevented backflow and check that the motor cooling fan has stopped. Start the pump again following the instructions of chapter 2.1.1 "Starting the pump".

If the pump intakes from a lower level than it is positioned, it can un-prime during the standstill and therefore you must check again before starting that the pump and the suction piping are full of liquid.

2. OPERATION

2.2. Stopping the pump



It is advisable to close the discharge shut-off / regulation valve gradually and stop the motor immediately after. The reverse sequence is not recommendable, especially with larger pumps or longer delivery piping. That is to avoid any problems due to water hammering. If a suction shutoff valve has been installed, it is advisable to close it completely after pump is fully stopped.

2.3. Cleaning and disinfection



Cleaning and disinfection of the pump system is of greatest importance when the pump is used in a food processing installation. Use of a pump system that is NOT cleaned or disinfected can cause contamination of the product. The cleaning cycles as well as chemicals to use for the cleaning vary depending on the pumped product and the process. The user is responsible to establish a suitable cleaning and / or disinfection program according to local and public health and safety regulations.

2.3.1. Cleaning procedure

The pump may be cleaned in two different ways:

CIP (Cleaning In Place)

without dismantling the pump, using steam, water or cleaning chemicals. Follow these safety instructions during the CIP procedure:



- Make sure that all cleaning line connections are properly tightened to avoid splashing of hot water or cleaning chemicals.
- When using an automatic process, a safety device should be installed to avoid unintentional automatic start-up of the pump.
- Before any disassembly of the pump, fittings or pipes, make sure that the cleaning cycle is finished.

Manual cleaning

by simply dismantling the pump casing, impeller and mechanical seal. Always follow these safety instructions:



- Switch off the electric power to the motor and disconnect the motor starting system if installed.
- The cleaning personnel shall wear suitable protective clothing, footwear and goggles.
- Use a suitable non-toxic and non-flammable cleaning solution.
- Always keep the area around the pump clean and dry.
- Never clean the pump by hand with pump running.

2. OPERATION

2.4. Residual risks

Even with proper application and observance of all points listed in this operating manual, there is still an estimable and unexpected residual risk when using the pumps. It may leak, fail due to wear, application-related causes or system-related circumstances.

2.5. Disposal after expiration of the expected lifetime

The metallic components like stainless steel can be recycled. Plastic parts are not recyclable and must be disposed of as residual waste. The pump must be disposed of properly, according to local regulations. It should be noted that potentially dangerous fluid residues may remain in the pump and can create a hazard to the operator or the environment, therefore the pump has to thoroughly cleaned before disposal.

2.6. Waste of electrical and electronic equipment (WEEE) directive

Users of electrical and electronic equipment (EEE) with the WEEE marking per Annex IV of the WEEE Directive must not dispose of end of life EEE as unsorted municipal waste, but use the collection framework available to them for the return, recycle, recovery of WEEE and minimize any potential effects of EEE on the environment and human health due to the presence of hazardous substances. The WEEE marking applies only to countries within the European Union (EU) and Norway. Appliances are labelled in accordance with European Directive 2002/96/EC. Contact your local waste recovery agency for a designated collection facility in your area.

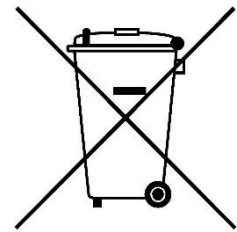

2.7. Actions in emergency

In the event of a leak during fluid transfer, the air supply have to be closed and the pressure released. During spillage of an aggressive liquid, local and national safety rules must be followed.

3. MAINTENANCE

3. MAINTENANCE



Maintenance work on electrical installations must be performed by qualified personnel and only when the power supply has been shut off. Follow the local and national safety regulations.

3.1. Inspections

- Periodically check suction and discharge pressures.
- Inspect the motor according to the instructions from the motor manufacturer.
- In general, a mechanical seal does not require maintenance, but the pump should never run when empty (dry). If a leakage occurs, replace the mechanical seal.
- Establish a preventive maintenance schedule based on the pump's service history.

3.2. Location of faults

Overheating of motor	Insufficient flow rate or pressure in pump	No pressure on the discharge	Irregular discharge flow / pressure	Noise and vibrations	The pump gets clogged	Overheating of the pump	Abnormal wear	Leak in mechanical seal	Possible reason	Solution
	X		X						Wrong direction of rotation	Invert the direction of rotation
	X	X	X	X					Insufficient suction head (NPSH)	Increase available NPSH: ➤ Raise the suction reservoir ➤ Lower the pump ➤ Increase the pressure in the suction tank ➤ Reduce the vapour pressure ➤ Increase the diameter of the suction pipe ➤ Make suction pipe short and direct
		X							Pump is clogged	Clean the pump
	X		X	X				X	Cavitation	Increase suction pressure
	X		X	X				X	The pump sucks air	Make sure all connections are tight
		X	X	X					Suction pipe is blocked	Check pipes / valves and filters on the suction line
	X			X					Discharge pressure too high	Reduce the head by increasing pipe diameter and/or reduce number of valves and bends
X				X		X			Flow rate too high	Reduce the flow: ➤ Partially close the discharge valve ➤ Reduce the impeller diameter (contact us) ➤ Reduce the rotation speed
	X			X	X	X	X		Liquid temperature too high	Cool the liquid
								X	Broken or worn mechanical seal	Replace the seal
								X	Wrong material of O-rings for the liquid	Mount O-rings in other material (contact us)
X				X	X	X			The impeller scratches	Reduce the temperature and / or suction pressure. Adjust clearance between housing and impeller
				X			X		Loads on the pipes	Connect the pipes independent of the pump
				X	X	X	X		Foreign objects in the liquid	Use a filter on the suction side
								X	Spring tension too low on mechanical seal	Adjust as mentioned in this manual
		X							Shut-off valve closed on suction side	Check and open the valve
	X								Discharge pressure too low	Increase the pressure – install an impeller with a bigger diameter (contact us)
					X	X			Pump is not filled with liquid	Fill pump with liquid
X	X			X					Liquid parameters different than calculated	Check pumped liquid parameters

3. MAINTENANCE

3.3. Disassembly of the pump



The disassembly should be performed only by qualified personnel.



Each operation to be fulfilled with the machine must always be carried out once all the electrical contacts have been disconnected. The pump-motor unit must be placed in a position where it cannot be started unintentionally.



Before servicing in any way the parts that come in contact with the pumped liquid, make sure that the pump has been fully emptied and washed. When draining the liquid, make sure that there is no danger for people or the environment.

The numbers put in brackets, refer to the part numbers in the spare part drawings and spare part lists in chapter 5. "Spare parts".

3.3.1. Disassembly procedure

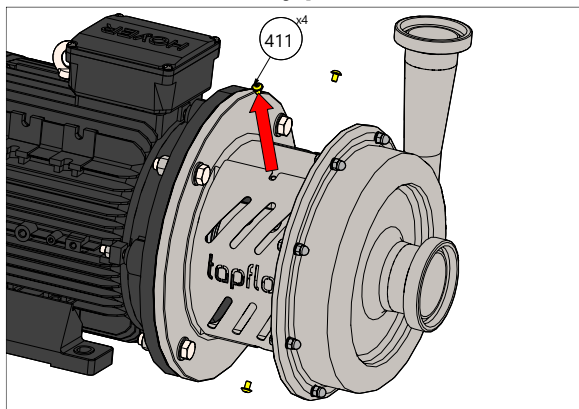

Fig. 3.3.1

Unscrew the shaft guard screws [411] fastening the shaft guards [41] to the lantern [11].

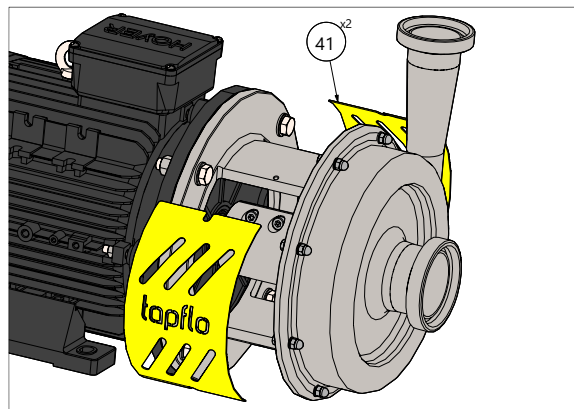

Fig. 3.3.2

Take off the shaft guards [41].

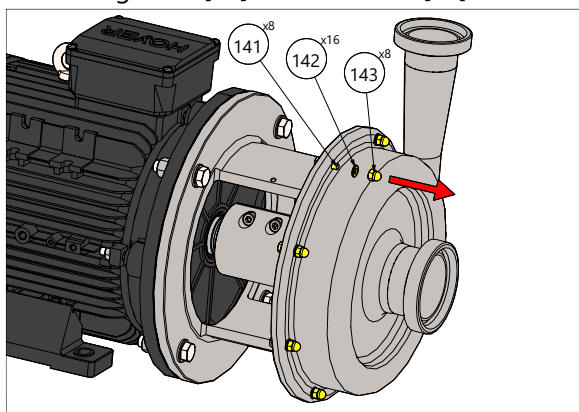

Fig. 3.3.3

Unscrew the casing mounting screws [141] and remove them with the nuts [143] and washers [142].

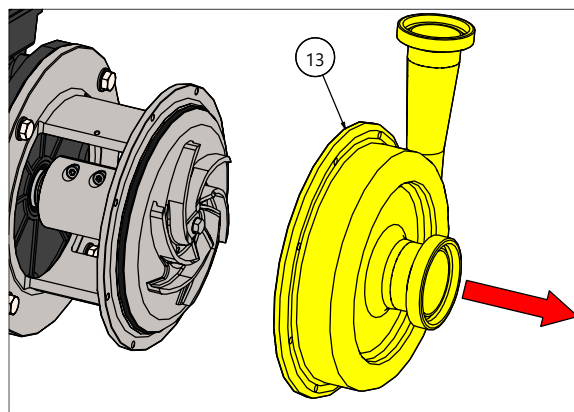

Fig. 3.3.4

Take off the pump casing [13].

3. MAINTENANCE

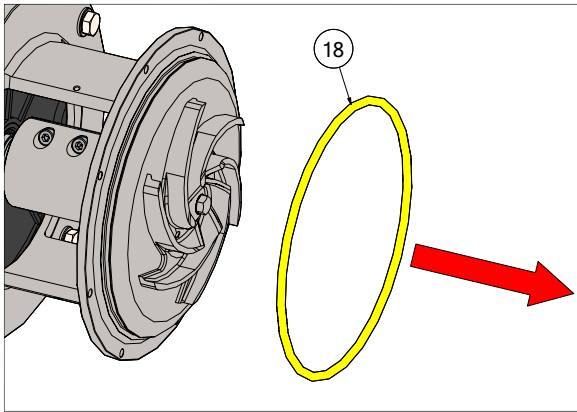

Fig 3.3.5

Remove the casing O-ring [18].

NOTE! After every disassembly the O-ring [18] should be replaced by a new one.

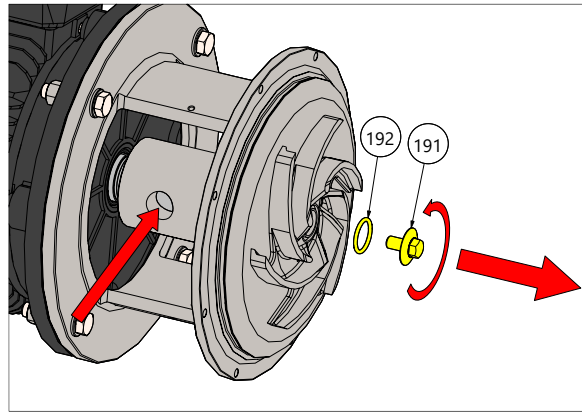

Fig 3.3.6

Use a bar to fix the shaft in place and unscrew the impeller nut [191] and remove the O-ring [192].

NOTE! Apply grease on the thread before re-assembly.

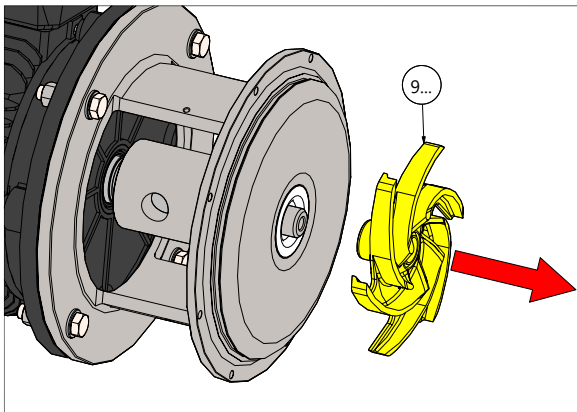

Fig 3.3.7

Unscrew the impeller [9...].

NOTE! Apply grease on the thread before re-assembly.

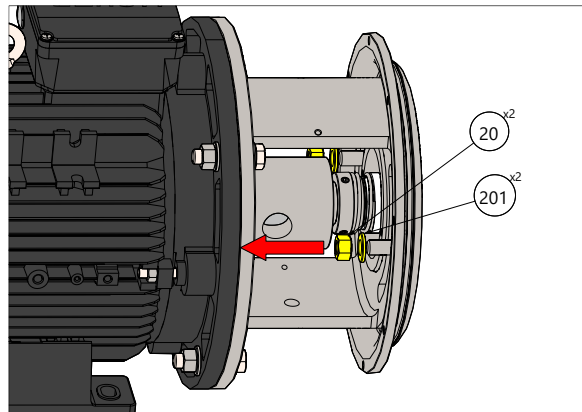

Fig 3.3.8

Remove the nuts [20] and washers [201] fastening the back casing [12] to the lantern [11].

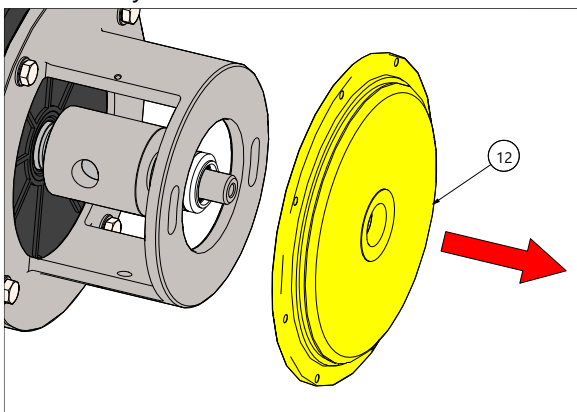

Fig 3.3.9

Carefully remove the back casing [12]. The static part of the mechanical seal will remain in the back casing.

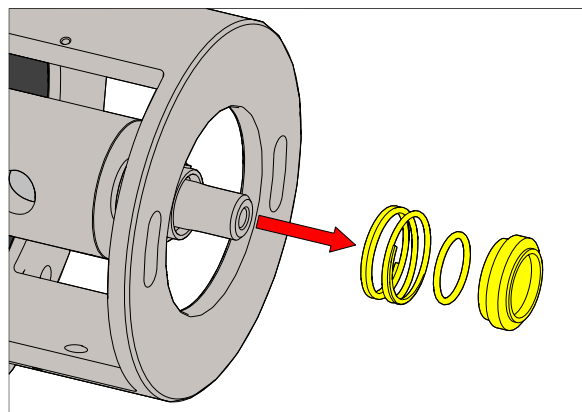

Fig 3.3.10

Remove the rotary parts of mechanical seal.

3. MAINTENANCE

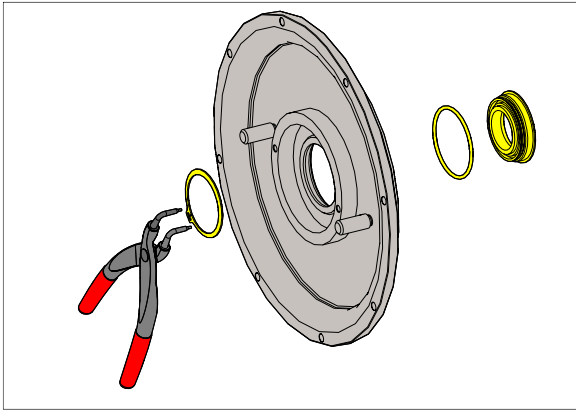

Fig 3.3.11
Remove the circlip by means of pliers and push out the static part of the mechanical seal.

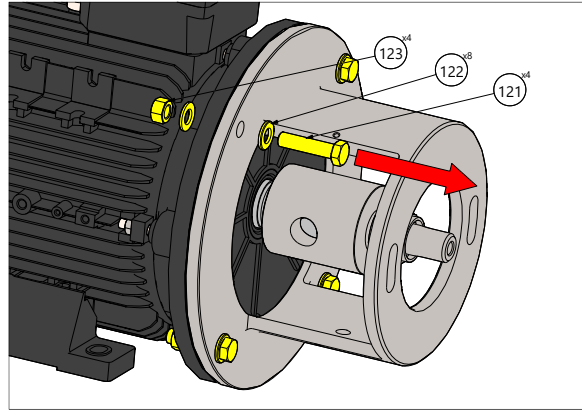

Fig 3.3.12
Remove the bolts [121], washers [122] and nuts [123] fastening the lantern [11] to the electric motor.

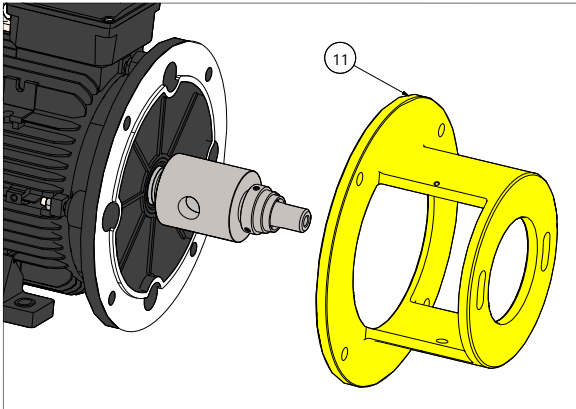

Fig 3.3.13
Remove the lantern [11].

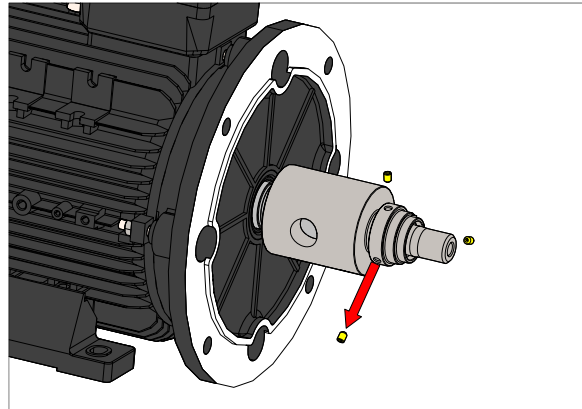

Fig 3.3.14
Remove the mechanical seal grub screws.

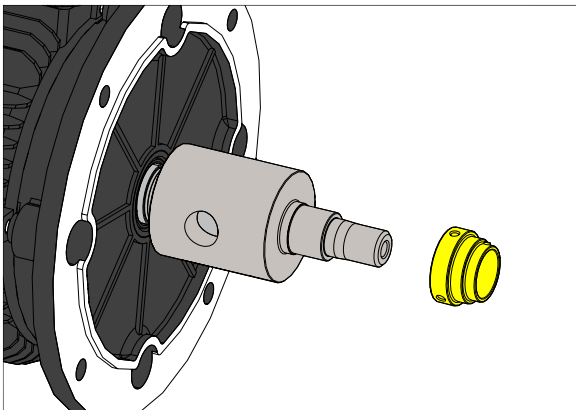

Fig 3.3.15
Remove the remaining part of mechanical seal.

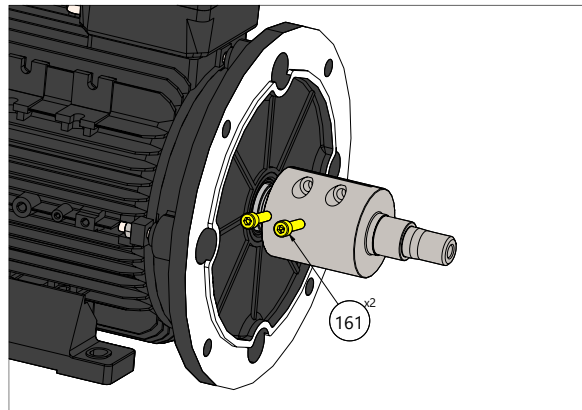

Fig 3.3.16
Remove the shaft screws [161].

3. MAINTENANCE

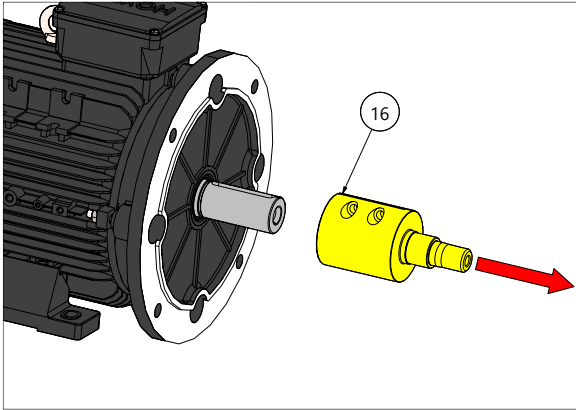

Fig 3.3.17
Remove the shaft [16].



The pump is now completely disassembled. Check all components, especially the mechanical seal, for wear or damage and replace if necessary. The casing O-ring should be replaced after every pump disassembly!

3.4. Assembly of the pump

The assembly procedure is done in the reverse order to the disassembly. Nevertheless there are a few things that you have to remember in order to assemble the pump correctly.

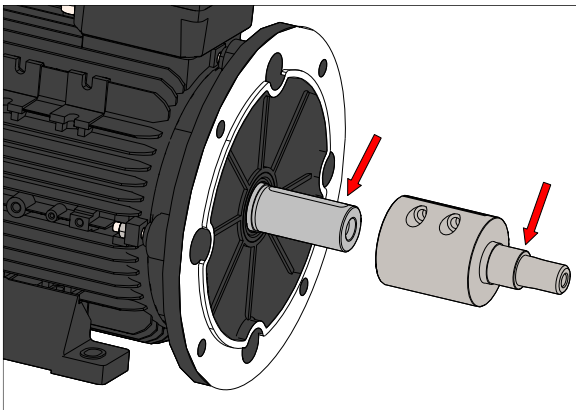

Fig. 3.4.1
Degrease the motor shaft and pump shaft before assembly.

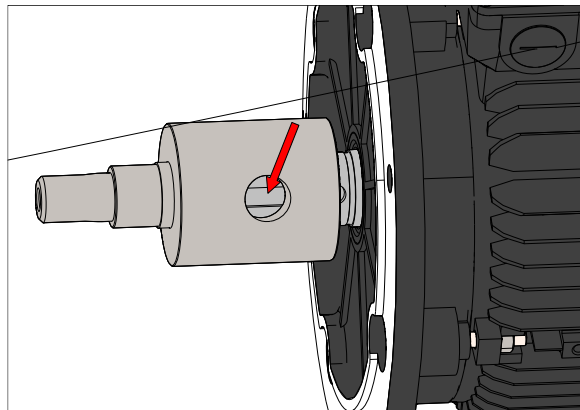

Fig. 3.4.2
Align keyseat with shaft hole.

3. MAINTENANCE

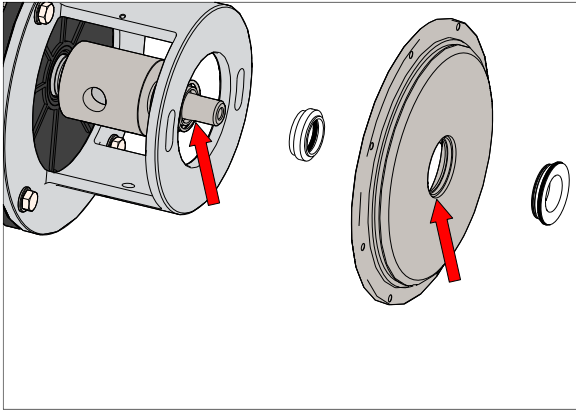

Fig. 3.4.3

Precisely clean and degrease with alcohol the internal rim of the back casing [12] as well as the shaft [16] surface. Check if the rim surface is smooth. If not it may cause mechanical seal leakage.

NOTE! For cleaning use dust-free material e.g. blue towel TORK 1230081.

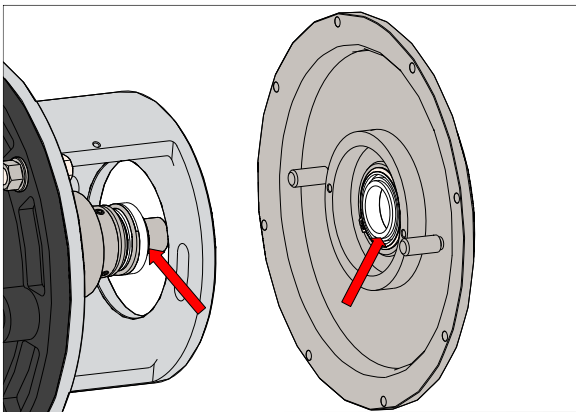

Fig. 3.4.5

Before final assembly, once again degrease the sliding faces of the mechanical seal.

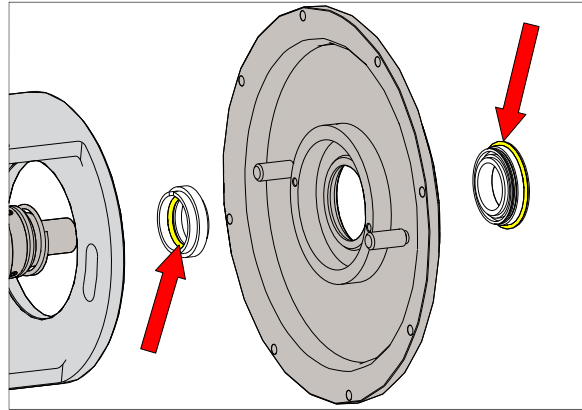

Fig. 3.4.4

Before assembly lubricate the mechanical seal O-rings to provide more accurate assembly as well as prevent the O-ring from curling.

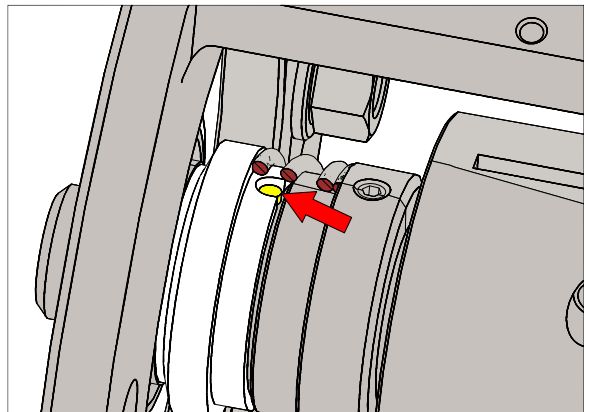

Fig. 3.4.6

Adjust retainer pin with rotary seal part groove.

3. MAINTENANCE

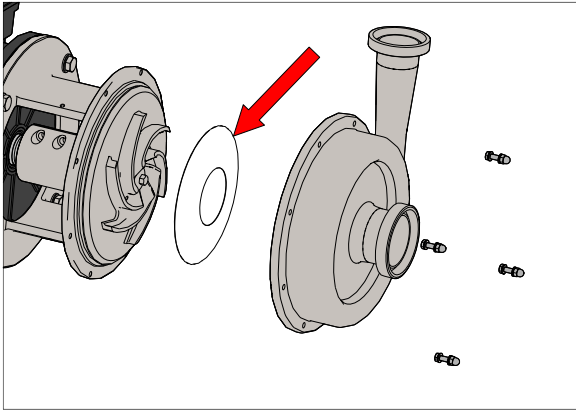

Fig. 3.4.7
Install back casing, impeller, insert spacer ring tool. Install casing, screw every second casing mounting screws nuts and washers.

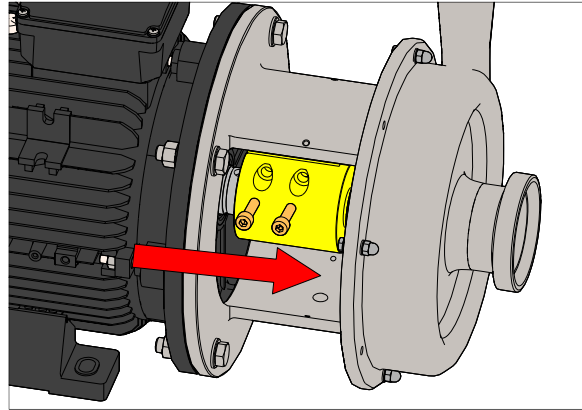

Fig. 3.4.8
Proper gap between the impeller and the back casing has to be set. Push the impeller to the housing through the shaft, then tighten the shaft screws.

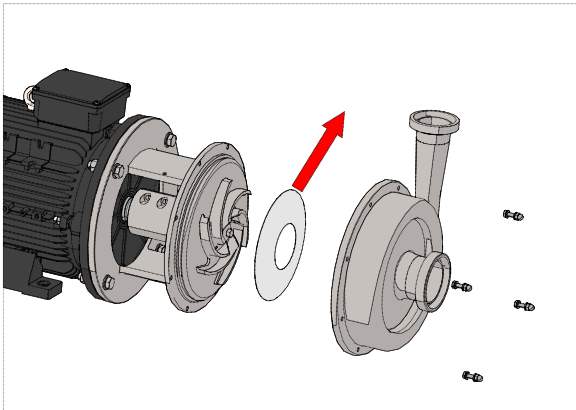

Fig. 3.4.9
Remove casing and spacer ring tool. Install casing O-Ring, lubricate it and install back casing with all screws.

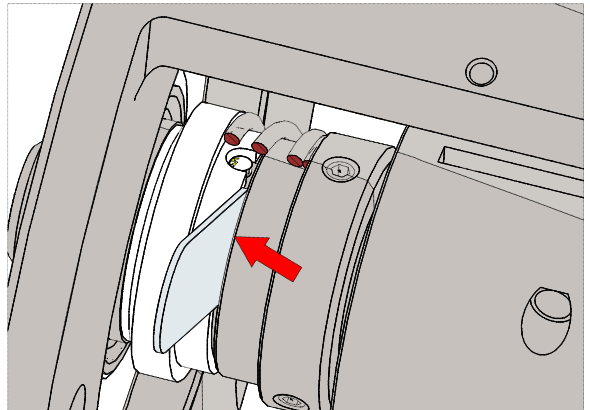
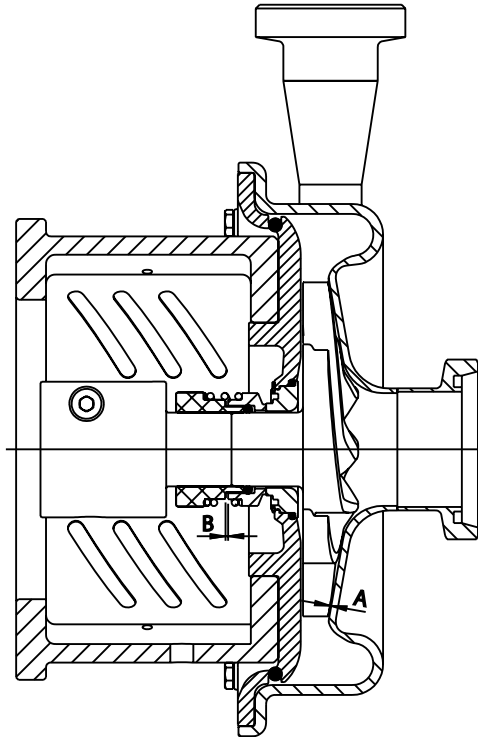

Fig. 3.4.10
By using a feeler (gap) gauge (**B**) set the appropriate gap between retainer and rotary seal part.

3. MAINTENANCE



After installation of the impeller, proper gap "A" between the impeller and the back casing has to be set. Loosen the shaft screws [161] and using a spacer ring tool(A) feeler (gap) gauge (B) set the appropriate gap.

Pump type	A [mm]	B [mm]
CTX 40-165	0.5	1.2
CTX 50-145		
CTX 50-200		
CTX 65-175	1.0	3
CTX 65-240		
CTX 65-230		
CTX 80-205		
CTX 80-212		
CTX 80-260		
CTX 100-230		

3.4.1. Test run



We recommend you to conduct a test run of the pump before installing it in the system, so no liquid gets wasted if the pump leaks or perhaps does not start accordingly to wrong assembly of the pump.

After a few weeks of operation retighten the screws with appropriate torque.

4. OPTIONS

4. OPTIONS

4.1. Motor shroud – M/N

An optional motor shroud is available. It is made of stainless steel and provides easy cleaning and splash protection for the electrical motor. As a standard, the pump with the shroud is equipped with feet (M) or bracket (N). Material execution of the shroud is AISI 304 stainless steel.

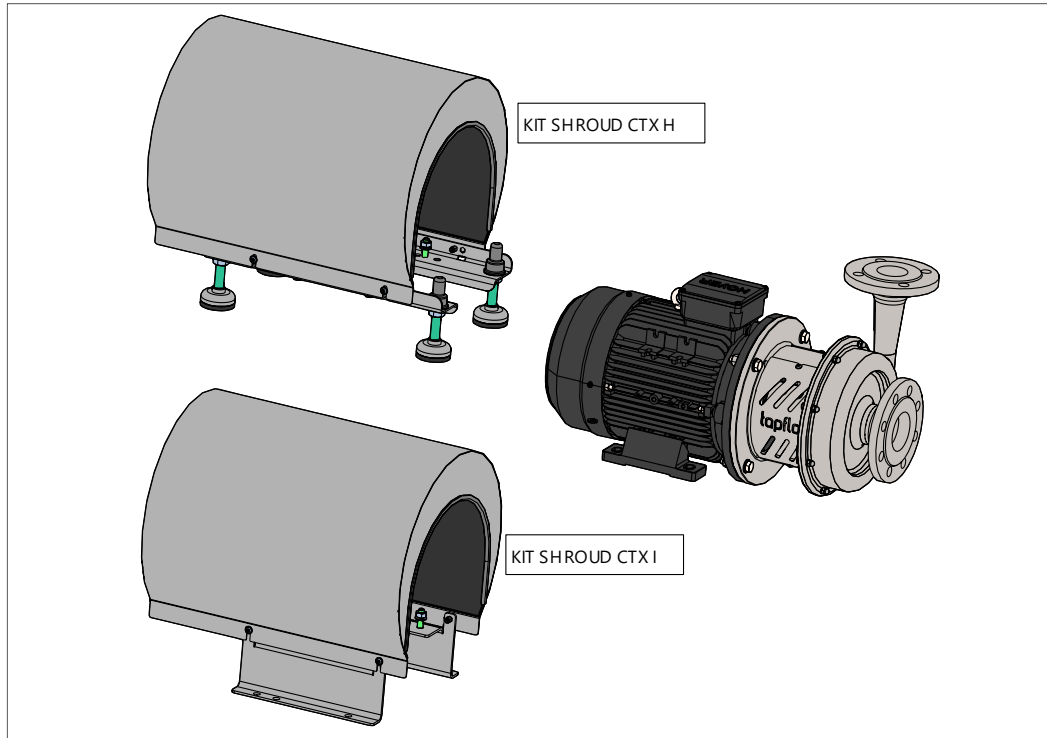

Available for all pump sizes

Code	Motor IEC size	Motor powers	Pump size
KIT SHROUD 90 X	90S / 90L	1.5 kW, 2.2 kW	40-165, 50-145
KIT SHROUD 100 X	100L	3.0 kW	40-165, 50-145, 65-175
KIT SHROUD 112 X	112M	4.0 kW	65-175
KIT SHROUD 132 X	132S	5.5 kW, 7.5 kW	50-200, 65-175, 65-230
KIT SHROUD 160 X	160M / 160L	11kW, 15 kW, 18.5 kW	50-200, 65-xxx, 80-xxx, 100-230
KIT SHROUD 180 X	180M	22 kW	65-240, 80-xxx, 100-230
KIT SHROUD 200 X	200L	30 kW, 37 kW	80-260, 100-230
KIT SHROUD 225 X	225M	45 kW	80-260, 100-230

X – M for hygienic and N for industrial execution

5. SPARE PARTS

5. SPARE PARTS

5.1. Spare parts drawing

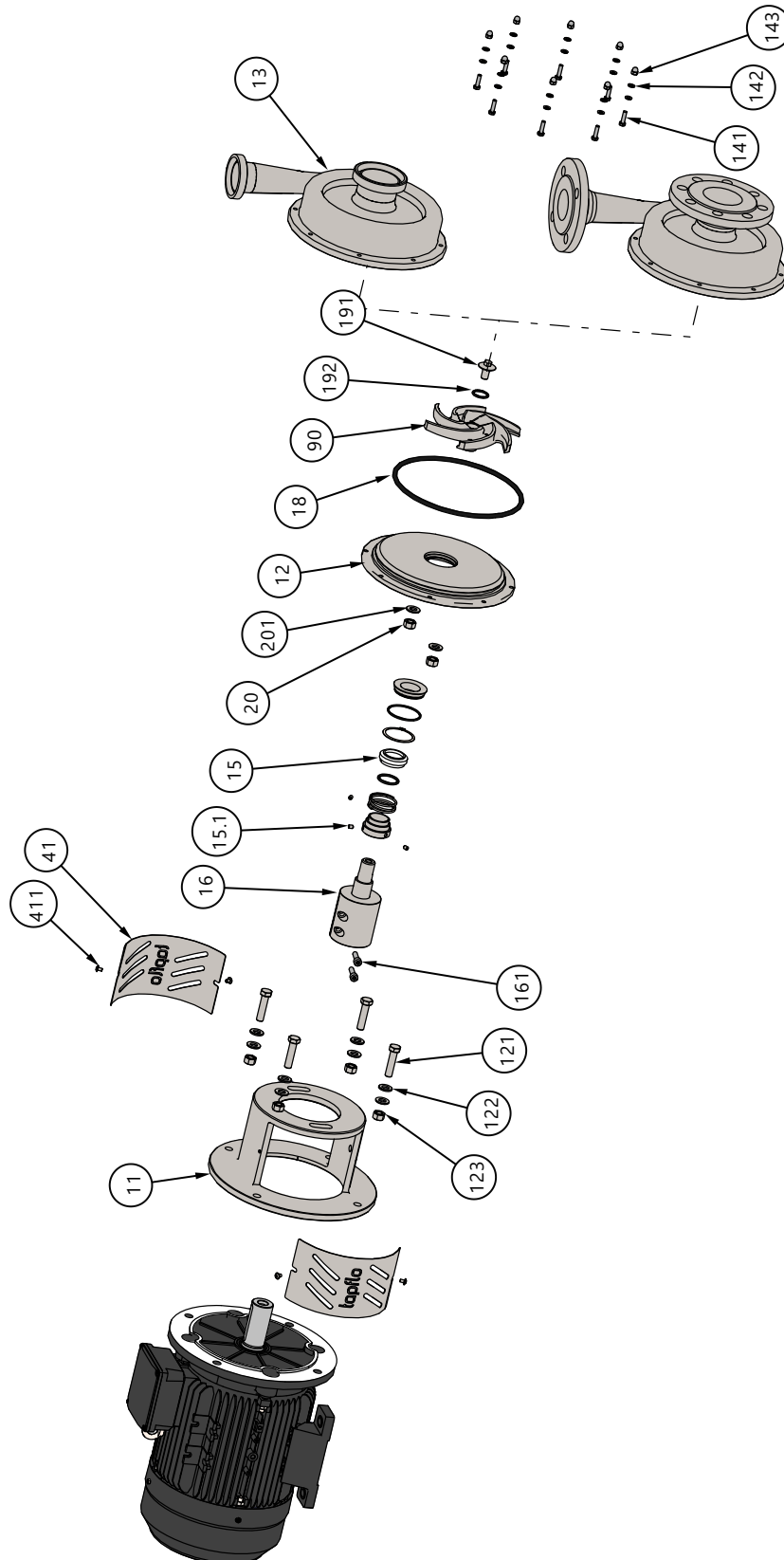

5. SPARE PARTS

5.2. Spare parts list

Pos.	Description	Q-ty	Material	
			CTX I	CTX H
11	Lantern	1	AISI 304	
12	Back casing [H/N]***	1	AISI 316L Ra<3.2	AISI 316L Ra<0.8
121	Lantern assembly bolt	4	A4-70	
122	Lantern assembly washer	8	A4-70	
123	Lantern assembly nut	4	A4-70	
13	Pump casing [H/N]	1	AISI 316L Ra<3.2	AISI 316L Ra<0.8
141	Casing mounting screws	8/6*	A4-70	
142	Casing mounting washers	16/12*	A4-70	
143	Casing mounting nuts	8/6*	A4-70	
15	Mechanical seal (complete)	1	See 6.1	See 6.1
16	Shaft extension	1	AISI 304L	
161	Shaft screw	2/1*	A4-80	
18	Casing O-ring	1	EPDM (std), FKM, Silicone, NBR	
191	Impeller mounting bolt [N/H]	1	AISI 316L Ra<3.2	AISI 316L Ra<0.8
192	Impeller bolt O-ring	1	EPDM (std), FKM, Silicone, NBR	
21	Back casing nut	4/2**	A4-70	
201	Back casing washer	4/2**	A4-70	
41	Shaft guard	2	AISI 304L	
411	Shaft guard screw	4	A2-70	
9xxx	Impeller (xxx – diameter in mm)	1	AISI 316L Ra<3.2	AISI 316L Ra<0.8



* CTX 100-230, 80-260, 80-212, 80-205, 65-240, 65-230, 65-175, 50-200 / 50-145, 40-165

** CTX 100-230, 80-260, 80-212, 80-205, 65-240, 65-230 / 65-175, 50-200, 50-145, 40-165

*** Parts indicated as [H/N] have different execution for CTX I and CTX H pumps. When ordering spare parts please indicate if the part is for Industrial or Hygienic series e.g. 14-145**N**-11 or 14-145**H**-11.

5.3. Recommended spare parts

Normally the CTX pump is maintenance free. However, depending on the nature of the liquid and temperature etc. some parts of the pump are subject to wear and need to be replaced. We recommend having the following parts in stock:

Pos.	Description	Q-ty
15	Mechanical seal	1
18	Casing O-ring	1
192	Impeller nut O-ring	1

5.4. How to order parts

When ordering spare parts for Tapflo pumps, please let us know what is the **model number** and **serial number** from the pump's name plate. Then just indicate the part numbers from the spare parts list and quantity of each item.

6. DATA

6. DATA

6.1. Pump code

The model number on the pump and on the front page of this instruction manual tells the pump size and materials of the pump.

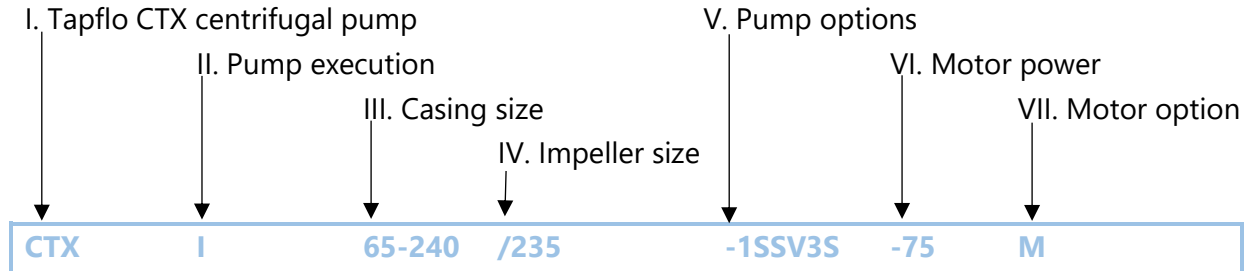

I. CTX = Tapflo CTX centrifugal pump

II. Pump execution:

- I = Industrial
- H = Hygienic

III. Pump size (inlet DN – max impeller diameter [mm]):

- 40-165
- 50-145
- 50-200
- 65-175
- 65-230
- 65-240
- 80-205
- 80-212
- 80-260
- 100-230

**IV. Actual impeller diameter [mm] used in pump
Trimming by 5 mm allowed**

	Max.	Min.
100-230	230	170
80-260	260	195
80-212	212	160
80-205	205	155
65-240	240	190
65-230	230	170
65-175	175	130
50-200	200	160
50-145	145	115
40-165	165	120

V. Pump options:

1. Mechanical seal (FDA as standard):

- Blank* = SiC/carbon/EPDM
- SSS = SiC/SiC/Silicone
- SSE = SiC/SiC/EPDM
- SSV = SiC/SiC/FKM
- SSN = SiC/SiC/NBR
- SGV = SiC/graphite/FKM
- SGS = SiC/graphite/Silicone
- SGN = SiC/graphite/NBR

2. Type of mechanical seal

- Blank* = Single mechanical seal
- D = Double mechanical seal – back-to-back

3. Connection options

- Blank* = EN 1092-1 flange on CTX I
Thread DIN 11851 on CTX H
- A = ANSI flange (CTX I only)
- B = BSPT female thread (CTX I only)
- C = SMS 3017 clamp (CTX H only)
- T = Clamp DIN 32676 (CTX H only)
- S = Thread SMS 1145 (CTX H only)
- R = Thread RJT (CTX H only)
- P = ISO 1127 clamp (CTX H only)
- W = No connection – plain weld end
- Z = Camlock male connection (CTX I only)

4. Special executions

- P05 = Extra polishing to Ra<0.5 (CTX H only)

VI. Motor power / IEC motor size

2900 rpm motors (2-pole):

- 15 = 1.5 kW / 90S
- 22 = 2.2 kW / 90L
- 30 = 3.0 kW / 100L
- 40 = 4.0 kW / 112M
- 55 = 5.5 kW / 132S
- 75 = 7.5 kW / 132S
- 110 = 11 kW / 160M
- 150 = 15 kW / 160M
- 185 = 18.5 kW / 160L
- 220 = 22 kW / 180M
- 300 = 30 kW / 200L
- 370 = 37 kW / 200L
- 450 = 45 kW / 225M

VII. Motor options

- M = Motor shroud with hygienic feet
- N = Motor shroud with mounting bracket
- V...F... = Motor for special voltage, frequency
- C = External cooling for motor
- UL = UL/CSA certified motor
- IP.. = IP class for motor
- D = Built on frequency inverter

* = standard execution

6. DATA

6.2. Dimensions

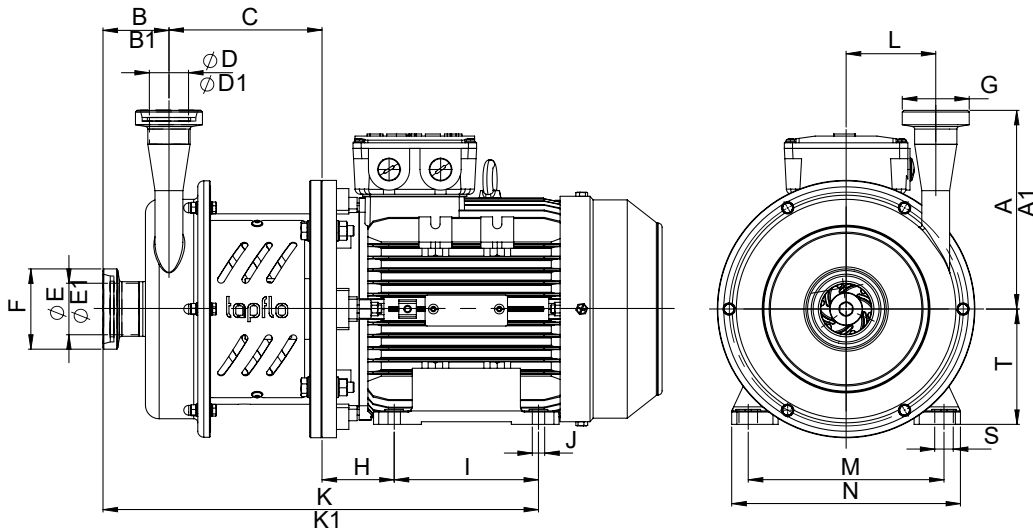

Dimensions in mm (where other is not indicated)

General dimensions only, ask us for detailed drawings. Changes reserved without notice.

MODEL	Power [kW]	IEC size	A	A1	B	B1	C	øD	øD1	øE	øE1	H*	I*	J*	K*	K1*	L	M*	N*	S*	T*					
40-165-15	1.5	90S	178	198	58.5	70.5	135	32	37.2	38	39.3	56	125	10	375	387	91	140	177	14	90					
40-165-22	2.2	90L					147					63						140			12	409	421	160	205	100
40-165-30	3.0	100L					171					70						12			416	428	190	222	112	
40-165-40	4.0	112M					89					459						471			216	256	132			
40-165-55	5.5	132S					132																			
40-165-75	7.5	132S	132																							
50-145-15	1.5	90S	193	205	64	82	137	38	39.3	50	54.5	56	125	10	382	400	87	140	177	14	90					
50-145-22	2.2	90L					149					63						140			12	416	434	160	205	100
50-145-30	3.0	100L					173					70						12			423	441	190	222	112	
50-145-40	4.0	112M					89					466						484			216	256	132			
50-145-55	5.5	132S					132																			
50-145-75	7.5	132S	132																							
50-200-30	3.0	100L	201	213	65.5	83.5	150	38	39.3	50	54.5	63	140	12	419	437	105	160	205	18	100					
50-200-40	4.0	112M					172					70						12			426	444	190	222	112	
50-200-55	5.5	132S					89					467						485			216	256	132			
50-200-75	7.5	132S					201					108						14.5			585	603	254	314	14.5	160
50-200-110	11	160M					254					629						647			160					
50-200-150	15	160M	160																							
50-200-185	18.5	160L	160																							
65-175-30	3.0	100L	231	249.5	75.5	88.5	149	50	54.5	66	70.3	63	140	12	428	441	100	160	205	18	100					
65-175-40	4.0	112M					171					70						12			435	448	190	222	112	
65-175-55	5.5	132S					89					476						489			216	256	132			
65-175-75	7.5	132S					200					108						14.5			594	607	254	314	14.5	160
65-175-110	11	160M					254					638						651			160					
65-175-150	15	160M	160																							
65-175-185	18.5	160L	160																							
65-240-55	5.5	132S	238	250	88	101	162	38	39.3	66	70.3	89	140	12	479	492	132	216	256	18	132					
65-240-75	7.5	132S					108					210						14.5			596	609	254	314	14.5	160
65-240-110	11	160M					254					640						653			160					
65-240-150	15	160M					121					241						18.5			716	729	279	349	180	
65-240-220	22	180M					133					305						18.5			716	729	318	388	18.5	200
65-240-300	30	200L	200																							
65-240-370	37	200L	200																							

6. DATA

65-240-450	45	225M											149			738	751		356	431		225
80-205-55	5.5	132S											89	140	12	495	501		216	256	18	132
80-205-75	7.5	132S																				132
80-205-110	11	160M																				160
80-205-150	15	160M											108	210	14.5	612	618		254	314	14.5	160
80-205-185	18.5	160L	240	258	96	101								254								160
80-205-220	22	180M											121	241		656	662		279	349		180
80-205-300	30	200L																				200
80-205-370	37	200L											133	305	18.5	732	738		318	388	18.5	200
80-205-450	45	225M											149			754.5	759.5		356	431		225
65-230-55	5.5	132S											89	140	12	486	491		216	256	18	132
65-230-75	7.5	132S																				132
65-230-110	11	160M																				160
65-230-150	15	160M											108	210	14.5	603	609		254	314	14.5	160
65-230-185	18.5	160L	240	258	87	92								254								160
65-230-220	22	180M											121	241		647	652		279	349		180
65-230-300	30	200L																				200
65-230-370	37	200L											133	305	18.5	723	728		318	388	18.5	200
65-230-450	45	225M											149			754.5	750		356	431		225
80-212-55	5.5	132S											89	140	12	498	504		216	256	18	132
80-212-75	7.5	132S																				132
80-212-110	11	160M																				160
80-212-150	15	160M											108	210	14.5	615	621		254	314	14.5	160
80-212-185	18.5	160L	272	285	99	104								254								160
80-212-220	22	180M											121	241		659	665		279	349		180
80-212-300	30	200L																				200
80-212-370	37	200L											133	305	18.5	735	741		318	388	18.5	200
80-212-450	45	225M											149			757.5	762.5		356	431		225
100-230-55	5.5	132S											89	140	12	508.5	519		216	256	18	132
100-230-75	7.5	132S																				132
100-230-110	11	160M																				160
100-230-150	15	160M											108	210	14.5	625.5	636		254	314	14.5	160
100-230-185	18.5	160L	292	297	94	99								254								160
100-230-220	22	180M											121	241		669.5	680		279	349		180
100-230-300	30	200L																				200
100-230-370	37	200L											133	305	18.5	745.5	756		318	388	18.5	200
100-230-450	45	225M											149	311		767.5	778		356	431		225
80-260-55	5.5	132S											89	140	12	493	497.5		216	256	18	132
80-260-75	7.5	132S																				132
80-260-110	11	160M																				160
80-260-150	15	160M											108	210	15	610	614.5		254	314	14.5	160
80-260-185	18.5	160L	272	284	94	99								254								160
80-260-220	22	180M											121	241		654	658.8		279	349		180
80-260-300	30	200L																				200
80-260-370	37	200L											133	305	19	730	734.5		318	388	18.5	200
80-260-450	45	225M											149	311		751.5	756.5		356	431		225

*Dimension may vary depending on motor brand

Dimensions A, B, D, E for sanitary version; A1, B1, D1, E1 for industrial version.

6. DATA

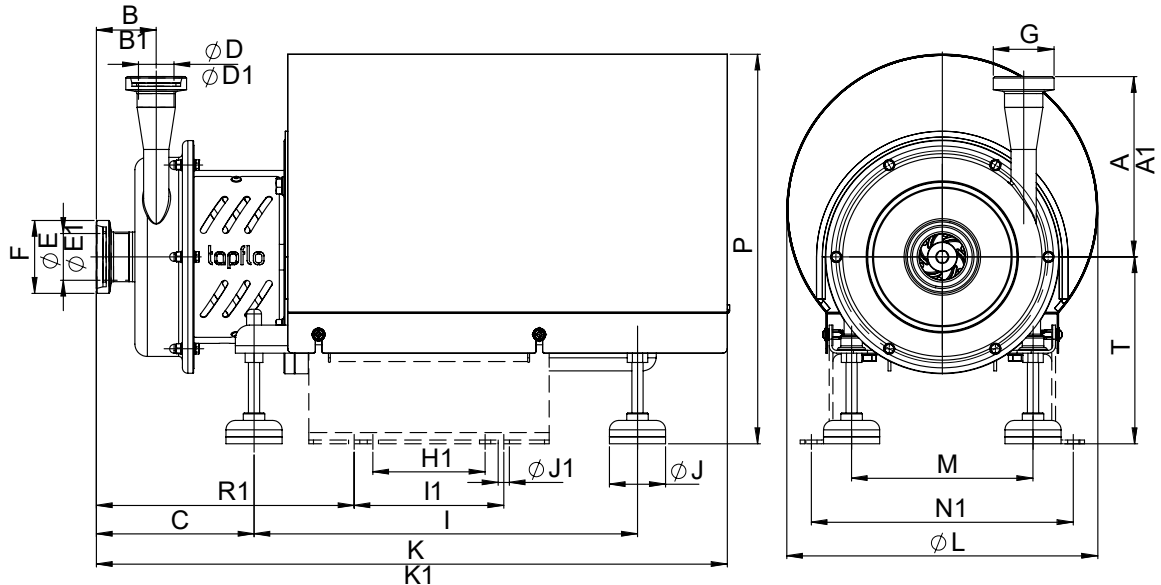

Dimensions in mm (where other is not indicated)

General dimensions only, ask us for detailed drawings. Changes reserved without notice.

MODEL	Power [kW]	IEC size	A	A1	B	B1	C	øD	øD1	øE	øE1	H1	I	I1	øJ	øJ1	K	K1	øL	M	N1	P	R1	T																									
40-165-15	1.5	90S	178	198	58.5	70.5	166	32	37.2	38	39.3	75	337	125	60	12	583	592.6	283	186/146**	230	370	261.5	190																									
40-165-22	2.2	90L					120					410	160																																				
40-165-30	3.0	100L					120					140	12/18*																																				
40-165-40	4.0	112M					12					722.5	734.5	402.5											226	320	465	330.5	225																				
40-165-55	5.5	132S					185.5					420	178	12											722.5	734.5	402.5	226	320	465	330.5	225																	
40-165-75	7.5	132S	185.5	420	178	12	722.5	734.5	402.5	226	320	465	330.5	225																																			
50-145-15	1.5	90S	193	205	64	82	173	38	39.3	50	54.5	75	337	125	60	12	587.5	605.5	283	186/146**	230	370	274.5	190																									
50-145-22	2.2	90L					120					410	160																																				
50-145-30	3.0	100L					120					140	12/18*																																				
50-145-40	4.0	112M					12					722.5	734.5	402.5											226	320	465	330.5	225																				
50-145-55	5.5	132S					185.5					420	178	12											722.5	734.5	402.5	226	320	465	330.5	225																	
50-145-75	7.5	132S	185.5	420	178	12	722.5	734.5	402.5	226	320	465	330.5	225																																			
50-200-30	3.0	100L	201	213	65.5	83.5	171.5	38	39.3	50	54.5	120	410	160	60	12	677.5	695.5	332.5	194	280	417	296.5	200																									
50-200-40	4.0	112M					120					140	12/18*																																				
50-200-55	5.5	132S					12					730.5	748.5	402.5											226	320	465	344.5	225																				
50-200-75	7.5	132S					12					730.5	748.5	402.5											226	320	465	344.5	225																				
50-200-110	11	160M					18					916.5	934.5	517.5											280	406	589	392.5	260																				
50-200-150	15	160M	18	916.5	934.5	517.5	280	406	589	392.5	260																																						
50-200-185	18.5	160L	18	916.5	934.5	517.5	280	406	589	392.5	260																																						
65-175-30	3.0	100L	231	249.5	75.5	88.5	180.5	50	54.5	66	70.3	120	410	160	60	12	686.5	699.5	332.5	194	280	417	300.5	200																									
65-175-40	4.0	112M					120					140	12/18*																																				
65-175-55	5.5	132S					12					739.5	752.5	402.5											226	320	465	348.5	225																				
65-175-75	7.5	132S					12					739.5	752.5	402.5											226	320	465	348.5	225																				
65-175-110	11	160M					18					925.5	938.5	517.5											280	406	589	396.5	260																				
65-175-150	15	160M	18	925.5	938.5	517.5	280	406	589	396.5	260																																						
65-175-185	18.5	160L	18	925.5	938.5	517.5	280	406	589	396.5	260																																						
65-240-55	5.5	132S	238	250	88	101	206	38	39.3	66	70.3	420	178	60	12	743	756	402.5	226	320	465	352	225																										
65-240-75	7.5	132S					600					290	18											928	941	517.5	280	406	589	399	260																		
65-240-110	11	160M					600					290																				18	928	941	517.5	280	406	589	399	260									
65-240-150	15	160M					600					290																													18	928	941	517.5	280	406	589	399	260
65-240-185	18.5	160L					600					290																																					
65-240-220	22	180M	645	315	18	968	981	552.5	316	442	621	412		280																																			
65-240-300	30	200L	645	315									18		968	981	552.5	316	442	621	412	280																											
65-240-370	37	200L	645	315																			18	968	981	552.5	316	442	621	412	280																		
65-240-450	45	225M	645	315																												18	968	981	552.5	316	442	621	412	280									
			229	760																																					18	1068	1081	617.5	342	512	674	424	300
			229	760	18	1068	1081	617.5	342	512	674	424		300																																			
			261	311									18		1131	1144	678	374	554	724	440	325																											
			261	311																			18	1131	1144	678	374	554	724	440	325																		
			261	311																												18	1131	1144	678	374	554	724	440	325									

6. DATA

80-205-55	5.5	132S	240	258	96	101	222.5	50	54.5	81	82.5	-	420	178	60	12	759.5	764.5	402.5	226	320	465	360.5	225
80-205-75	7.5	132S					247.5					600	290	944.5			949.5	517.5	280	406	589	407.5	260	
80-205-110	11	160M					250.5					645	315	984.5			989.5	552.5	316	442	621	420.5	280	
80-205-150	15	160M					244.5					229	760	305			1085	1090	617.5	342	512	674	432.5	300
80-205-185	18.5	160L					265.5					261	311	1147			1152	678	374	554	724	448.5	325	
80-205-220	22	180M					213					420	178	748			755	402.5	226	320	465	351	225	
80-205-300	30	200L					238					600	290	935			940	517.5	280	406	589	398	260	
80-205-370	37	200L					241					645	315	975			978	552.5	316	442	621	411	280	
80-205-450	45	225S					235					229	760	305			1075	1080	617.5	342	512	674	423	300
65-230-55	5.5	132S	240	258	87	92	213	50	54.5	66	70.3	-	420	178	60	12	748	755	402.5	226	320	465	351	225
65-230-75	7.5	132S					238					600	290	935			940	517.5	280	406	589	398	260	
65-230-110	11	160M					241					645	315	975			978	552.5	316	442	621	411	280	
65-230-150	15	160M					235					229	760	305			1075	1080	617.5	342	512	674	423	300
65-230-185	18.5	160L					251					261	311	1138			1143	678	374	554	724	439	325	
65-230-220	22	180M					213					420	178	748			755	402.5	226	320	465	351	225	
65-230-300	30	200L					238					600	290	935			940	517.5	280	406	589	398	260	
65-230-370	37	200L					241					645	315	975			978	552.5	316	442	621	411	280	
65-230-450	35	225S					235					229	760	305			1075	1080	617.5	342	512	674	423	300
80-212-55	5.5	132S	272	285	99	104	225.5	66	70.3	81	82.5	-	420	178	60	12	762.5	767.5	402.5	226	320	465	363.5	225
80-212-75	7.5	132S					250.5					600	290	947.5			952.5	517.5	280	406	589	410.5	260	
80-212-110	11	160M					253.5					645	315	987.5			992.5	552.5	316	442	621	423.5	280	
80-212-150	15	160M					247.5					229	760	305			1088	1093	617.5	342	512	674	435.5	300
80-212-185	18.5	160L					263.5					261	311	1150			1155	678	374	554	724	451.5	325	
80-212-220	22	180M					213					420	178	762.5			767.5	402.5	226	320	465	363.5	225	
80-212-300	30	200L					238					600	290	947.5			952.5	517.5	280	406	589	410.5	260	
80-212-370	37	200L					247.5					645	315	987.5			992.5	552.5	316	442	621	423.5	280	
80-212-450	45	225S					263.5					261	311	1150			1155	678	374	554	724	451.5	325	
80-260-55	5.5	132S	272	284	94	99	219.5	66	70.3	81	82.5	-	420	178	60	12	759	764	402.5	226	320	465	357.5	225
80-260-75	7.5	132S					244.5					130	600	290			944	949	517.5	280	406	589	404.5	260
80-260-110	11	160M					247.5					167	645	315			984	989	552.5	316	442	621	417.5	280
80-260-150	15	160M					241.5					229	760	305			1084	1089	617.5	342	512	674	429.5	300
80-260-185	18.5	160L					257.5					261	311	1144			1149	678	374	554	724	445.5	325	
80-260-220	22	180M					213					420	178	748			755	402.2	226	320	465	379	225	
80-260-300	30	200L					247.5					600	290	944			949	517.5	280	406	589	404.5	260	
80-260-370	37	200L					241.5					645	315	984			989	552.5	316	442	621	417.5	280	
80-260-450	45	225S					257.5					261	311	1144			1149	678	374	554	724	445.5	325	
100-230-55	5.5	132S	292	297	94	99	235.5	81	82.5	100	107.1	-	420	178	60	12	775	785.5	402.2	226	320	465	379	225
100-230-75	7.5	132S					260.5					130	600	290			960	970.5	517.5	280	406	589	426	260
100-230-110	11	160M					263.5					167	645	315			1000	1011	552.5	316	442	621	439	280
100-230-150	15	160M					257.5					229	760	305			1100	1111	617.5	342	512	674	451	300
100-230-185	18.5	160L					273.5					261	311	1160			1171	678	374	554	724	467	325	
100-230-220	22	180M					213					420	178	775			785.5	402.2	226	320	465	379	225	
100-230-300	30	200L					260.5					600	290	960			970.5	517.5	280	406	589	426	260	
100-230-370	37	200L					263.5					645	315	1000			1011	552.5	316	442	621	439	280	
100-230-450	45	225S					273.5					261	311	1160			1171	678	374	554	724	467	325	

*Kidney shaped hole – width/length

** Front feet wider than rear feet

Dimensions A, B, D, E, I, J, K, M for sanitary version; A1, B1, D1, E1, H1, I1, J1, K1, N1, R1 for industrial version.

6. DATA

Connection dimensions						
Model	BSPT male thread		EN1092-1 flange (std.)		ANSI 150 flange	
	F	G	F	G	F	G
40-165	1.5"	1.25"	DN40	DN32	1.5"	1.25"
50-145	2"	1.5"	DN50	DN40	2"	1.5"
50-200	2"	1.5"	DN50	DN40	2"	1.5"
65-175	2.5"	2"	DN65	DN50	2.5"	2"
65-230	2.5"	2"	DN65	DN50	2.5"	2"
65-240	2.5"	1.5"	DN65	DN40	2.5"	1.5"
80-205	3"	2"	DN80	DN50	3"	2"
80-212	3"	2.5"	DN80	DN65	3"	2.5"
80-260	3"	2.5"	DN80	DN65	3"	2.5"
100-230	4"	3"	DN100	DN80	4"	3"





Connection dimensions										
Model	DIN 11851 thread (std.)		DIN 32676 clamp		SMS3017 clamp		SMS 1145 thread		RJT thread	
	F	G	F	G	F	G	F	G	F	G
40-165	DN40	DN32	DN40	DN32	38	33.7	38	32	1.5"	1.25"
50-145	DN50	DN40	DN50	DN40	51	38	51	38	2"	1.5"
50-200	DN50	DN40	DN50	DN40	51	38	51	38	2"	1.5"
65-175	DN65	DN50	DN65	DN50	63.5	51	63.5	51	2.5"	2"
65-230	DN65	DN50	DN65	DN50	63.5	51	63.5	51	2.5"	2"
65-240	DN65	DN40	DN65	DN40	63.5	38	63.5	38	2.5"	1.5"
80-205	DN80	DN50	DN80	DN50	76.1	51	76	51	3"	2"
80-212	DN80	DN65	DN80	DN65	76.1	63.5	76	63.5	3"	2.5"
80-260	DN80	DN65	DN80	DN65	76.1	63.5	76	63.5	3"	2.5"
100-230	DN100	DN80	DN100	DN80	101.6	76.1	108	76	4"	3"

6.3. Materials, data and limits

	CTX H ...	CTX I ...
Casing	Stainless steel AISI 316L electro polished Ra<0.8	Stainless steel AISI 316L sand blasted Ra<3.2
Open impeller	Stainless steel AISI 316L electro polished Ra<0.8	Stainless steel AISI 316L electro polished Ra<3.2
Mechanical seal	Single, SiC/carbon (std) or SiC/SiC, FDA approved	Single, SiC/carbon (std) or SiC/SiC, FDA approved
O-rings	EPDM, FKM, NBR (all FDA approved)	EPDM, FKM, NBR (all FDA approved)
Motor	IP55; IEC frame B35; PTC thermistor; IE3; 3-phase	
Pressure rating @ 20°C	PN10 – CTX 40-165, CTX 50-145, CTX 50-200, CTX 65-175 PN16 – CTX 65-230, CTX 65-240, CTX 80-205, CTX 80-212, CTX 80-260, CTX 100-230	
Liquid temp.	(-10)÷120 °C (140°C for short periods during SiP)	
Ambient temp.	(-20)÷40 °C	
Viscosity	Max ~150 cSt	

6. DATA

6.4. Mounting torques and dimensions of screws/nuts

Screw / nut type	Description	CTX 40-165 CTX 50-145	CTX 50-200	CTX 65-175	CTX 65-230; CTX 65-240; CTX 80-205; CTX 80-212; CTX 80-260; CTX 100-230
	Pos. 141. DIN 933 bolt Mounting torque [Nm] Tool size "S" [mm] Thread	8 10 M6	8 10 M6	8 10 M6	20 13 M8
	Pos. 161. DIN 912 screw Mounting torque [Nm] Tool size "S" [mm] Thread	25 6 M8	25 6 M8	25 6 M8	25 6 M8
	Pos. 121. DIN 933 bolt Mounting torque [Nm] Tool size "S" [mm] Thread	35 17 M10	60 19 M12	60 19 M12	140 24 M16
-	Pos. 191. bolt Mounting torque [Nm] Tool size "S" [mm] Thread	40 12 M12	65 12 M14	40 12 M12	65 12 M14
	Pos.20. DIN 934 nut Mounting torque [Nm] Tool size "S" [mm] Thread	40 19 M12	40 19 M12	40 19 M12	40 19 M12
	Pos. 15.1. DIN 916 set screw Mounting torque [Nm] Tool size "S" [mm] Thread	2.5 3 M6	2.5 3 M6	2.5 3 M6	2.5 3 M6

6. DATA

6.5. Performance curves

The performance curves are based on water at 20°C.
Contact us for detailed curves

Speed 2900 rpm

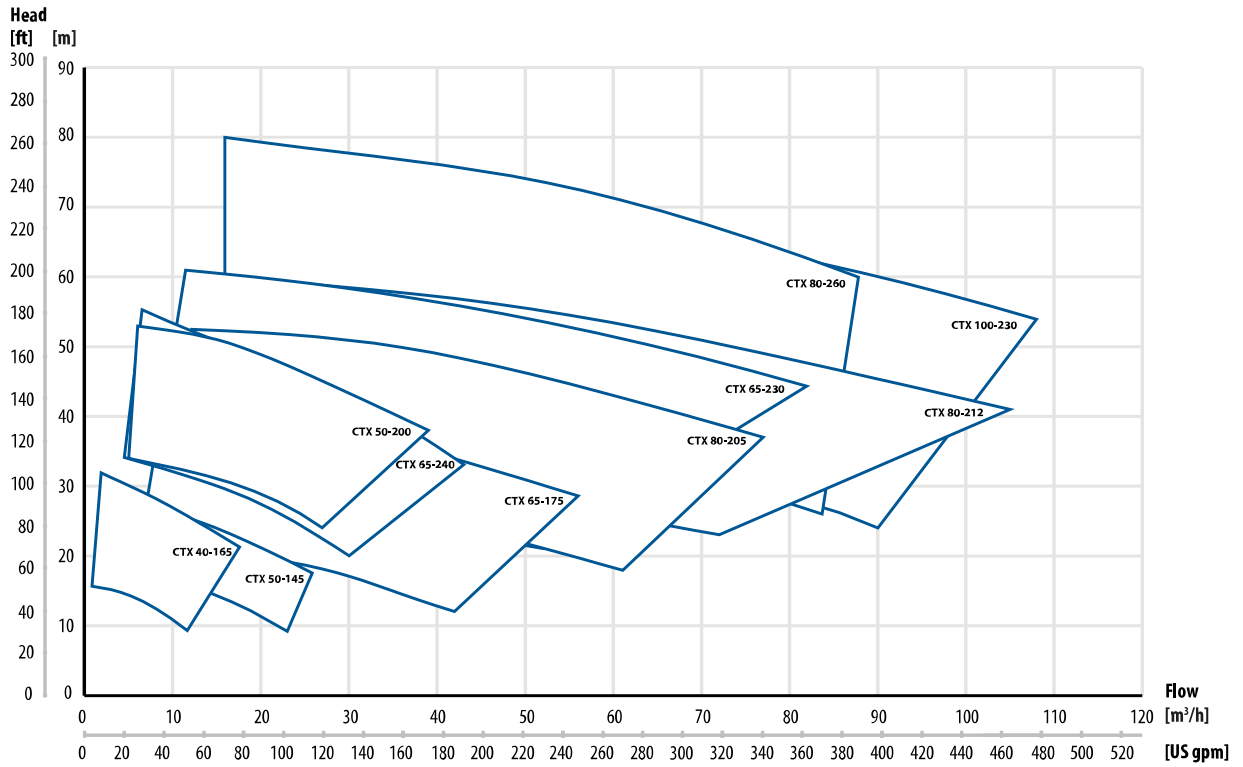

6. DATA

6.6. Permitted loads on inlet and outlet

We recommend not to exceed the following loads and forces reacting on the inlet and outlet.

CTX I/H 40-165		
Direction	Load [N] (inlet/outlet)	Moment of force (inlet/outlet) [Nm]
X	65/55	26/4
Y	65/55	24/4
Z	65/55	24/3

CTX I/H 50-145		
Direction	Load [N] (inlet/outlet)	Moment of force (inlet/outlet) [Nm]
X	90/65	44/4
Y	90/65	17/4
Z	90/65	18/4

CTX I/H 50-200		
Direction	Load [N] (inlet/outlet)	Moment of force (inlet/outlet) [Nm]
X	90/65	45/5
Y	90/65	17/5
Z	90/65	17/5

CTX I/H 65-175		
Direction	Load [N] (inlet/outlet)	Moment of force (inlet/outlet) [Nm]
X	115/90	104/10
Y	115/90	39/10
Z	115/90	39/11

CTX I/H 65-230		
Direction	Load [N] (inlet/outlet)	Moment of force (inlet/outlet) [Nm]
X	115/65	103/5
Y	115/65	39/7
Z	115/65	39/5

CTX I/H 65-240		
Direction	Load [N] (inlet/outlet)	Moment of force (inlet/outlet) [Nm]
X	115/90	103/13
Y	115/90	39/11
Z	115/90	39/14

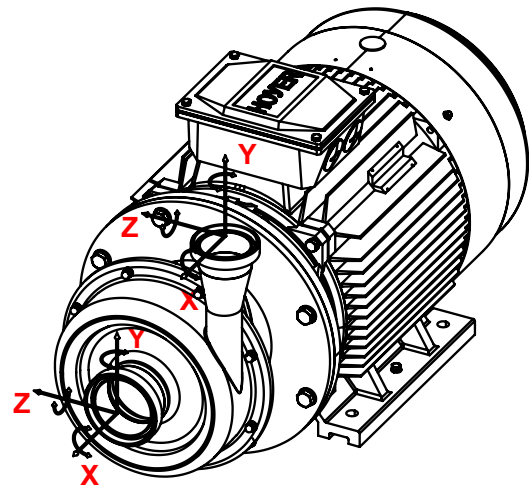

CTX I/H 80-205		
Direction	Load [N] (inlet/outlet)	Moment of force (inlet/outlet) [Nm]
X	135/90	157/16
Y	135/90	68/11
Z	135/90	68/15

CTX I/H 80-212		
Direction	Load [N] (inlet/outlet)	Moment of force (inlet/outlet) [Nm]
X	135/115	239/22
Y	135/115	182/16
Z	135/115	182/21

CTX I/H 80-260		
Direction	Load [N] (inlet/outlet)	Moment of force (inlet/outlet) [Nm]
X	135/115	159/32
Y	135/115	70/28
Z	135/115	69/34

CTX I/H 100-230		
Direction	Load [N] (inlet/outlet)	Moment of force (inlet/outlet) [Nm]
X	180/135	243/39
Y	180/135	83/45
Z	180/135	83/50

7. WARRANTY

7. WARRANTY

7.1. Returning parts

When returning parts to Tapflo please follow this procedure:

- Consult Tapflo for shipping instructions.
- Cleanse or neutralize and rinse the part/pump. Make sure the part/pump is completely empty from liquid.
- Pack the return articles carefully to prevent any damage during transportation.

Goods will not be accepted unless the above procedure has been complied with.

7.2. Warranty

Tapflo warrants products under conditions as stated below for a period of not more than 12 months from installation and not more than 24 months from date of manufacturing.

1. The following terms and conditions apply to the sale of machinery, components and related services and products, of Tapflo (hereinafter "the products").
2. Tapflo (the manufacturer) warrants that:
 - a. its products are free of defects in material, design and workmanship at the time of original purchase;
 - b. its products will function in accordance with Tapflo operative manuals; Tapflo does not guarantee that the product will meet the precise needs of the Customer except for those purposes set out in any invitation to render documents or other documents specifically made available to Tapflo before entering into this agreement;
 - c. high quality materials are used in the construction of the pumps and that machining and assembly are carried out to the highest standards.

Except as expressly stated above, Tapflo makes no warranties, express or implied, concerning the products, including all warranties of fitness for a particular purpose.

3. This warranty shall not be applicable in circumstances other than defects in material, design and workmanship. In particular warranty shall not cover the following:
 - a. Periodic checks, maintenance, repair and replacement of parts due to normal wear and tear (seals, O-rings, rubber items, bushings, etc.);
 - b. Damage to the product resulting from:
 - b.1. Tampering with, abuse or misuse, including but not limited to failure to use the product for its normal purposes as stated at the time of purchase or in accordance with Tapflo instructions for use and maintenance of the product, or the installation or improper ventilation or use of the product in a manner inconsistent with the technical or safety standard in force;
 - b.2. Repairs performed by non-skilled personnel or use of non-original Tapflo parts;

7. WARRANTY

b.3. Accidents or any cause beyond the control of Tapflo, including but not limited to lightning, water, fire, earthquake and public disturbances etc.;

4. The warrantee shall cover the replacement or repairing of any parts, which is documented faulty due to construction or assembling, with new or repaired parts free of charges delivered by Tapflo. Parts subjected to normal tear and wear shall not be covered by the warranty. Tapflo shall decide as to whether the defective or faulty part shall be replaced or repaired.
5. The warrantee of the products shall be valid for a period in accordance to the current law from the date of delivery, under the condition that notice of the alleged defect to the products or parts thereof be given to Tapflo in written within the mandatory term of 8 days from the discovery. Repair or replacement under the terms of this warranty shall not give a right to an extension to or a new commencement of the period of warranty.
6. Repair or replacement under the terms of this warranty shall not give a right to an extension to, or a new commencement of, the period of warranty. Repair or replacement under the terms of this warranty may be fulfilled with functionally equivalent reconditioned units. Tapflo qualified personnel shall be solely entitled to carry out repair or replacement of faulty parts after careful examination of the pump. Replaced faulty parts or components will become the property of Tapflo.
7. The products are built in accordance with standard CE normative and are tested (where applicable) by Tapflo. Approval and tests by other control authority are for the customer's account. The products shall not be considered defective in materials, design or workmanship if they need to be adapted, changed or adjusted to conform to national or local technical or safety standards in force in any country other than that for which the unit was originally designed and manufactured. This warranty shall not reimburse such adaptations, changes or adjustments, or attempt to do so. whether properly performed or not, nor any damage resulting from them, nor any adaptation change or adjustments to upgrade the products from their normal purpose as described in the products operative manual without the prior written consent of Tapflo.
8. Installation, including electric and other connections to utility mains according to Tapflo drawings, is for the cost and responsibility of the customer, unless otherwise agreed in writing.
9. Tapflo will not be liable on any claim, whether in contract, tort, or otherwise, for any indirect, special, incidental or consequential damages caused to the customer or to third parties, including loss of profits arising by any possible infringement of par. 3 above or by the customer or third parties being in the impossibility of using the products.

Steady the above, Tapflo liability to the customer or third parties from any claim, whether in contract, tort or otherwise, shall be limited to the total amount paid by the customer for the product that caused the damages.

7. WARRANTY

7.3. Warranty form

Company: _____	
Telephone: _____	Fax: _____
Address: _____	
Country: _____	Contact Name: _____
E-mail: _____	
Delivery Date: _____	Date of pump installation: _____
Pump type: _____	
Serial No (see name plate): _____	
Description of the fault: _____	

The installation:	
Liquid: _____	
Temperature [°C]: _____	Viscosity [cPs]: _____ Spec grav. [kg/m ³]: _____ pH-value: _____
Content of particles: _____	% of max size [mm]: _____
Flow [l/min]: _____	Duty [h/day]: _____ No of starts per day: _____
Discharge head [mWC]: _____	Suction head / lift [m]: _____
Other: _____	

Place for sketch of installation:	

Sweden

Filaregatan 4 | S-442 34 Kungälv

Tel: +46 303 63390

Fax: +46 303 19916

E-mail addresses:

Commercial questions: sales@tapflo.com

Orders: order@tapflo.com

Tech support: support@tapflo.com

Tapflo products and services are available worldwide.

Tapflo is represented by own Tapflo Group Companies and carefully selected distributors assuring highest Tapflo service quality for our customers' convenience.

AUSTRALIA | AUSTRIA | AZERBAIJAN | BAHRAIN | BELGIUM | BOSNIA | BRAZIL | BULGARIA | CANADA | CHILE | CHINA | COLOMBIA | CROATIA | CZECH REPUBLIC | DENMARK | ECUADOR | EGYPT | ESTONIA | FINLAND | FRANCE | GEORGIA | GERMANY | GREECE | HONG-KONG | HUNGARY | ICELAND | INDIA | INDONESIA | IRELAND | ISRAEL | ITALY | JAPAN | JORDAN | KAZAKHSTAN | KUWAIT | LATVIA | LIBYA | LITHUANIA | MACEDONIA | MALAYSIA | MEXICO | MONTENEGRO | MOROCCO | NETHERLANDS | NEW ZEALAND | NORWAY | OMAN | PHILIPPINES | POLAND | PORTUGAL | QATAR | ROMANIA | SAUDI ARABIA | SERBIA | SINGAPORE | SLOVAKIA | SLOVENIA | SOUTH AFRICA | SOUTH KOREA | SPAIN | SWEDEN | SWITZERLAND | TAIWAN | THAILAND | TURKEY | UKRAINE | UNITED ARAB EMIRATES | UNITED KINGDOM | USA | UZBEKISTAN | VIETNAM

Tapflo Group Companies

Australia

Tapflo Oceania (Pty) Ltd.
Tel: +61 1800303633
sales@tapflo.com.au

China

Tapflo (Wuxi) Pumps Co. Ltd.
Tel: +86 51082417072
sales@tapflo.cn

Ireland

Tapflo Ireland Ltd.
Tel: +353 12011911
info@tapflo.ie

Poland

Tapflo Sp. z o.o.
Tel: +48 609 995 500
info@tapflo.pl

Spain

Tapflo Ibérica S.L.
Tel: +34 918093182
avives@tapfloiberica.es

Uzbekistan

Tapflo Uzbekistan
Tel: +998 712370940
sales@tapflo.uz

Austria

Tapflo GmbH
Tel: +43 73227292910
sales@tapflo.at

Croatia

Tapflo d.o.o.
Tel: +385 914884666
sales@tapflo.hr

Italy

Tapflo Italia S.r.l.
Tel: +39 0362306528
info@tapfloitalia.com

Qatar

Tapflo Gulf General Trading Co. L.L.C
Tel: +971 58 582 3630
sales@tapfloqulf.com

South Africa

Tapflo (Pty) Ltd.
Tel: +27 317015255
sales@tapflo.co.za

Bahrain

Tapflo Gulf General Trading Co. L.L.C
Tel: +971 58 582 3630
sales@tapfloqulf.com

Czech Republic

Tapflo s.r.o.
Tel: +420 513033920
tapflo@tapflo.cz

Japan

Tapflo Japan K.K.
Tel: +81 362403510
tapflojp@tapflo.co.jp

Romania

S.C. Tapflo Rom. S.r.l.
Tel: +40 213451255
sales@tapflo.ro

Sweden

Tapflo AB Tel: +46
(0)30314050 info@tapflo.com

Baltic States

Tapflo SIA
Tel: +371 67472205
sales@tapflo.lv

Denmark

Tapflo Danmark ApS
Tel: +45 36454600
info@tapflo.dk

Kazakhstan

Tapflo LLP
Tel: +7 727 327 83 47
sales@tapflo.kz

Saudi Arabia

Tapflo Gulf General Trading Co. L.L.C
Tel: +971 58 582 3630
sales@tapfloqulf.com

Turkey

Tapflo Makina Ltd.
Tel: +90 2164673311
sales@tapflo.com.tr

Belgium

Tapflo Benelux B.V.
Tel: +31 (0) 6 21850664
info@tapflo.nl

France

Sarl Tapflo France
Tel: +33188788240
info@tapflo.fr

Kuwait

Tapflo Gulf General Trading Co. L.L.C
Tel: +971 58 582 3630
sales@tapfloqulf.com

Serbia

Tapflo d.o.o.
Tel: +381 21445808
sales@tapflo.rs

Ukraine

Tapflo LLC
Tel: +380 442226844
sales@tapflo.ua

Bulgaria

Tapflo EOOD
Tel: +359 886 124 937
office@tapflo.bg

Hungary

Tapflo Kft.
Tel: +36 30148 8551
office@tapflo.hu

Netherlands

Tapflo Benelux B.V.
Tel: +31 (0) 6 21850664
info@tapflo.nl

Slovakia

Tapflo s.r.o.
Tel: +421 911137883
tapflo@tapflo.sk

Canada

Tapflo Canada
Tel: +1 514 409 8380
office@tapflo.ca

India

Tapflo Fluid Handling India Pvt Ltd.
Tel: +91 9028574063
enquiry@tapflo.in

Oman

Tapflo Gulf General Trading Co. L.L.C
Tel: +971 58 582 3630
sales@tapfloqulf.com

Slovenia

Tapflo d.o.o.
Tel: +386 68613474
sales@tapflo.hr

United Arab Emirates

Tapflo Gulf General Trading Co. L.L.C
Tel: +971 58 582 3630
sales@tapfloqulf.com

United Kingdom

Tapflo (UK) Ltd.
Tel: +44 2380252325
sales@tapflo pumps.co.uk



If your country is not listed please visit www.tapflo.com/en/contact