

tapflo®

# HYGIENIC TWIN SCREW PUMPS

2026| 1



» All about your flow™

[www.tapflo.com](http://www.tapflo.com)

## » All about your flow™

*We began our journey 40 years ago in Kungälv, a small town on the Swedish west coast, as a family company with an ambition to one day become a global player on the pump market.*

Since 1980, we have taken pride in delivering a wealth of knowledge and passion for pumps to the industry, whilst supplying a wide range of premium products for various industrial applications.

Over the years, the company has developed into a global Tapflo Group with branches and distributors present in nearly every region of the world.

One thing did not change - we are still a family company.

Our solutions are designed and manufactured in Europe and distributed globally to offer the best service and flow solutions to our customers for a variety of applications.

Our values, Commitment, Quality and Simplicity are reflected both in our product and business approach.



**For fast and flexible service and high-quality products readily available worldwide, choose Tapflo.**

## Quality commitment

At Tapflo we are simply committed to quality. As a result, our production standards, as well as products quality, comply with various globally recognised certification and quality control standards. The Tapflo manufacturing process is certified according to ISO 9001:2015, confirming that our processes are appropriate, effective, customer-focused and continuously improved.



## Tapflo values

Our culture is concluded in Our values

### Commitment

We are different from our competitors because of our willingness to exceed the customers' expectations, move fast and be flexible. Our culture is based on the spirit of togetherness, enthusiasm and integrity. We come from all over the world but we share the same values and we respect each other. We are committed.

### Quality

We understand that the quality in our work is never better than the weakest link, that's why we focus on every small detail. We share a common passion for continuously finding more efficient and effective ways to provide value to our customers. As a manufacturer we have control of the complete process both in terms of our products and the way we operate internally. That is why we manufacture the highest quality pumps in our segment.

### Simplicity

We have a saying, "Simple is art" which means we try to find smooth and uncomplicated solutions in everything. By keeping it simple we can focus on the essential, like designing uncomplicated pumps with few components. For us it is a key to success; strive to simplify what is complex.

# Hygienic Twin Screw Pumps

Rotating positive displacement pumps .....



**FMH** - high pressure - EHEDG & 3A compliant - customizable version

**LMH** - high capacity - standard hygienic version

**LMHi300** - high pressure & high capacity (hybrid version)

Each pump can be customized for a specific application allowing the customer to be served in an optimal way. Several screws profiles and several materials available allow them to be optimized for each particular application.

One pair of screws, which operate without being in contact with each other, ensures a constant flow, pulsation-free, together with a high suction lift capability with very low NPSH values.

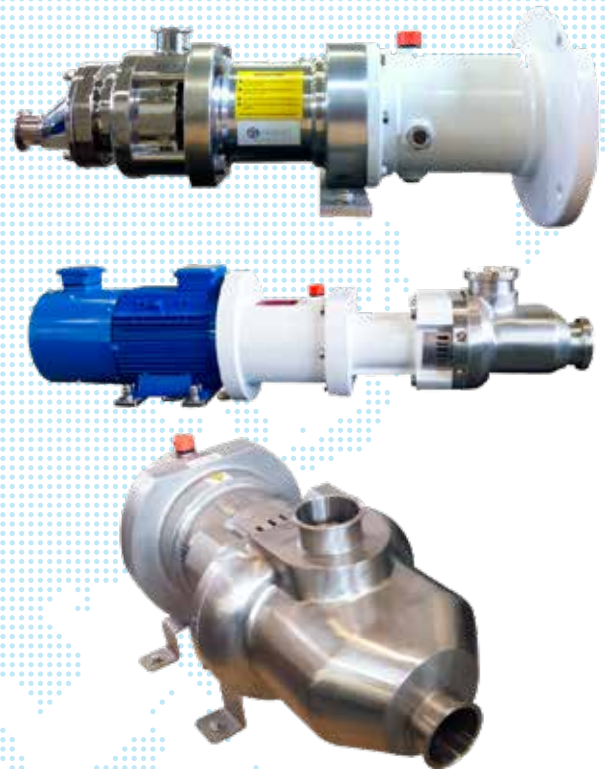

## Fast facts

Capacity:	up to 180 m <sup>3</sup> /h
Differential Pressure:	up to 16 bar
Rotation Speed:	up to 3000 rpm
Medium Temperature:	-20 °C   + 140 °C
Viscosity:	up to 1 000 000 cSt

## Features & Benefits

- ✓ **2 in 1 principle**  
Thanks to the wide range of speeds, it is possible to pump the product and clean in place (CIP) with only one pump! Angular speed range between 100 and 3000 RPM.
- ✓ **Best operating principle with longest life and less maintenance**  
The screws are rotating inside the pump casing without any contact. Wear-out is minimized, also on applications with abrasive and non-lubricating fluids, including dissolved gas/air.
- ✓ **Upgrading the hygienic standards**  
pumps are available in full EHEDG and 3-A compliant execution.
- ✓ **One pump for many operating conditions - highest flexibility**  
The FMH and LMH pumps can fit many operating conditions, thanks to their wide speed range. It is possible to generate different capacities and pressure ranges with a wide range of viscosities and temperatures.
- ✓ **Improve the final quality of the product by using the best pumps**  
Thanks to the operating principle of the pumps, the product is conveyed very smoothly and gently, with almost no pulsations.
- ✓ **Fully cleanable in place (CIP) and Sterilisable in place (SIP).**  
CIP and SIP are pumps procedures for cleaning and disinfecting without major disassembly and assembly work. Twin Screw Pumps can be used also as a CIP Pump, with the benefit of eliminating the need of another pump dedicated only to CIP (and any eventual accessories that would be needed for that).

## Working principle

The Screws Pair rotates inside the Pump Enclosure, creating several separate chambers and pushing the fluid trapped inside in accordance with the progression of the screws pitch.

The flow rate is particularly uniform and pulsation-free, and the pumped fluid flows in an axial direction (not circumferentially, as it happens in the centrifugal pumps)

The result of the screws rotation is a gentle movement of the displaced volume, in not turbulent conditions, making it ideal for handling shear-sensitive fluids or liquids easily subject to emulsification.



## Wide range of applications

The portfolio of FMH-LMH series offers a solution for almost any application. But also for special customers request we supply optimal solutions.



# Construction

FMH & LMH twin screw pumps are single flow and self-priming. Two non-contacting intermeshing screws and the pump housing form closed chambers that, according to the direction of rotation, constantly move towards the pressure discharge end of the pump.

## Material & Surface Finishing

- » Pump wetted parts (by the product) are designed for food contact and in Stainless Steel 316L grade
- » Surface roughness less than 0,8 micron Ra, as a Standard
- » FDA Compliant Elastomers

## Engineered Screws

Each pump can be provided with many screw pitches and with single or double profiles, for obtaining the best performance for each customized requirement and for larger solids handling.

## Customized Connection

- » The most common DIN hygienic connections are available as standard execution
- » Other connections, like: Tri-clamp, SMS, BS, are available on request.

## Three Part Design

Pump housing is made of 3 parts, that allow easy disassembly for manual cleaning, inspection and maintenance.

## Optimized Bearing Unit

- » Bearing Housing designed for smoothening vibrations and for hosting higher volume of lubricating oil, for better cooling
- » Specially Engineered Bearings Arrangement suitable to handle high pressures and reverse pumping
- » Timing Gears for synchronizing the 2 screws and permitting no contact movement in the pumping chamber
- » Bearing Housing available in SS316 or Cast Iron materials, for wash-down duty or more cost effective solutions
- » Closed coupling joint version available on most pump sizes;
- » Short assembly version, with motor output shaft is optional

## Customized Feet Arrangement

- » Levelling feet, anti-vibration type, standard for most pump sizes, allowing better cleanability under the pump
- » Fixed feet execution available for Stainless Steel Baseplate option

## Hygienic Engineered Mechanical Seals

- » Single, Single Flushed, Double type available
- » Soft or Hard Seal Surfaces available
- » Several Soft Part Materials available
- » Modular design available, with the possibility of retrofitting/upgrading the mechanical seal from single to double
- » Hygienic design, with no dead-ends (no product accumulation)
- » Fast and Easy Maintenance

## OPTIONS:

- » Heating jacket
- » Twin auger feeder system
- » Other options

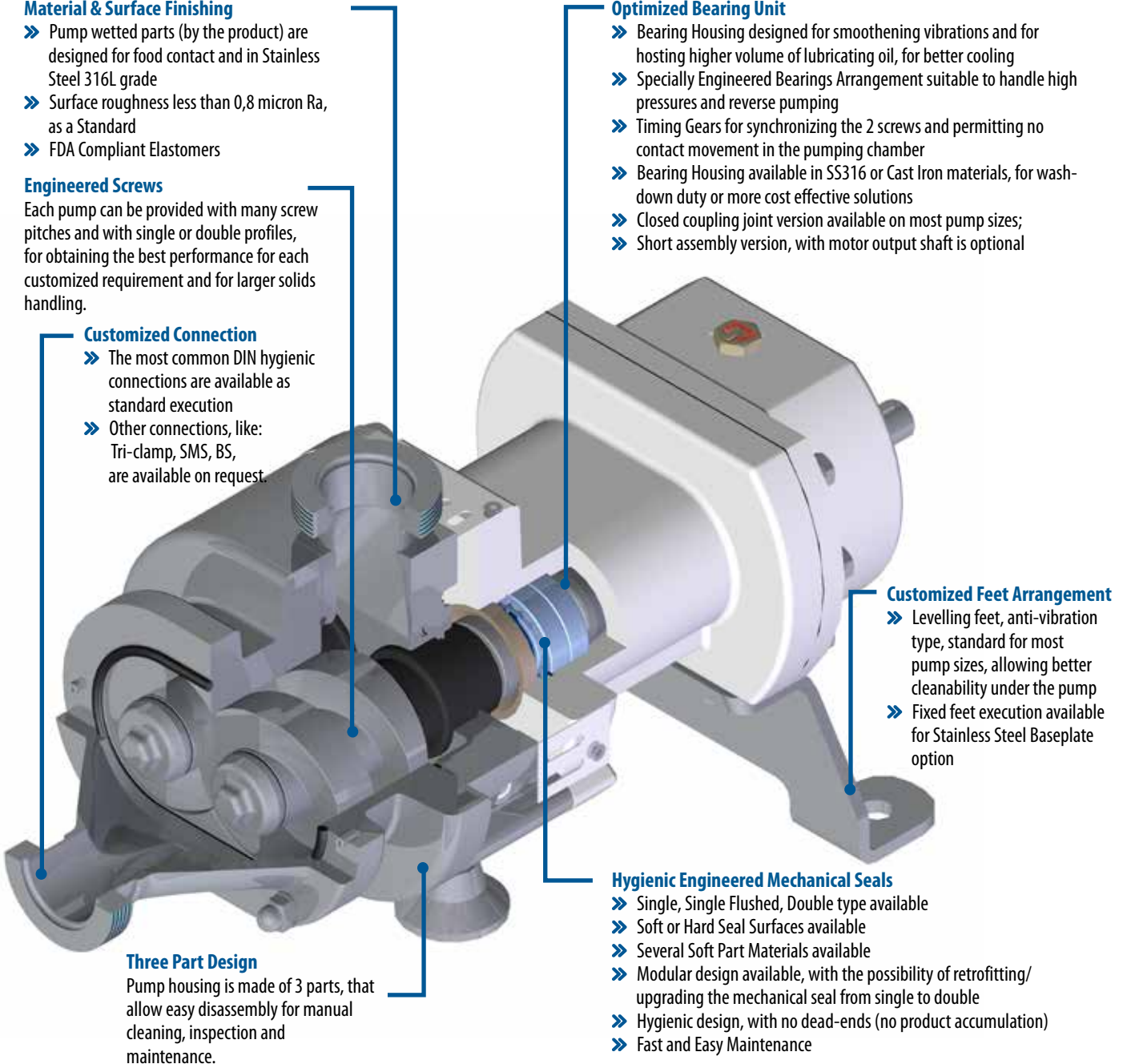

## Technical data

Pump Model	FMH 50	FMH 100	FMH 200
Capacity:	up to 12 m <sup>3</sup> /h 53 gpm	up to 22 m <sup>3</sup> /h 88 gpm	up to 30 m <sup>3</sup> /h 132 gpm
Differential Pressure:	up to 16 bar   232 psi		
Rotation speed:	up to 3000 rpm		
Medium Temperature:	-20 / +140 °C   -4 / 284 °F (160°C   320°F with oil cooler)		
Viscosity:	Up to 1.000.000 cSt		
Inlet / Outlet	1½"   1½"	2"   2"	3"   2½"

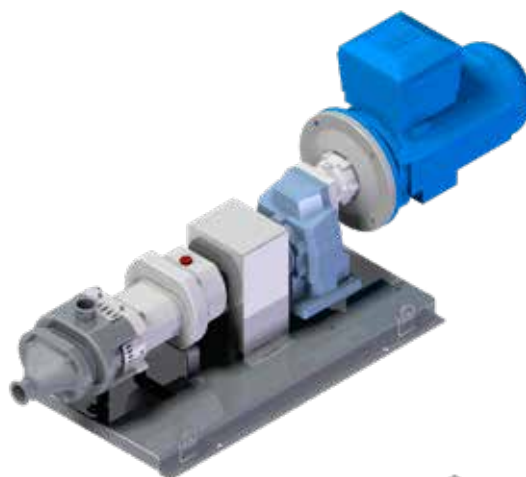

Pump Model	LMH 50	LMH 100	LMH 200	LMH300i
Capacity:	up to 16 m <sup>3</sup> /h 70 gpm	up to 32 m <sup>3</sup> /h 141 gpm	up to 72 m <sup>3</sup> /h 317 gpm	up to 180 m <sup>3</sup> /h 793 gpm
Differential Pressure:	up to 6 bar 87 psi			up to 16 bar 232 psi
Rotation speed:	up to 3000 rpm	up to 2600 rpm up to 2200 rpm		
Medium Temperature:	-20 / +140 °C   -4 / 284 °F (160°C   320°F with oil cooler)			
Viscosity:	Up to 1.000.000 cSt			
Inlet   Outlet	1½"   1½"	2"   2"	3"   2½"	4"   4"

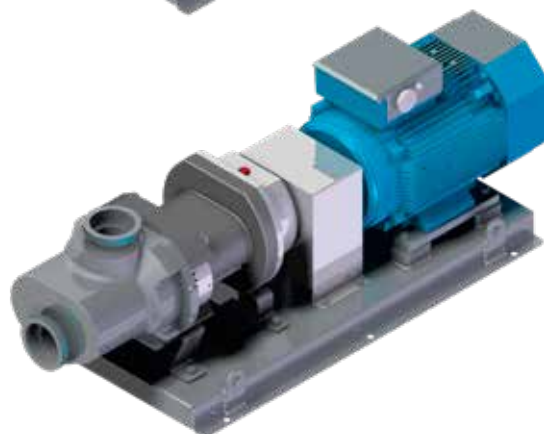

## Dimensional drawing

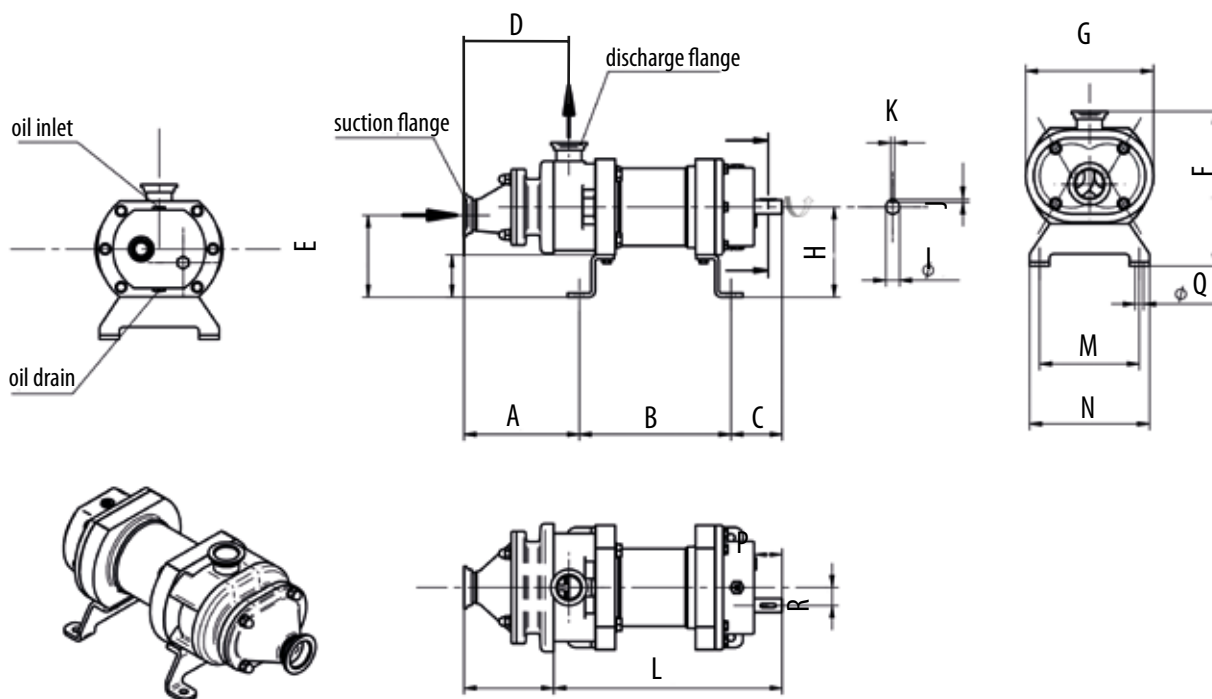

Type	A	B	C	D	E	F	G	H	I	J	K	L	M	N	O	P	Q	R
FMH50	180	242	91	163	100	217	202	119	18	3,5	6	270	151,5	197	163	40	12	28
FMH100	222	316	99	217	179	317	247	179	22	3,5	6	445	200	250	192	50	18	34
FMH200	289	380	128	262	205	386	320	225	35	8	10	440	250	300	259	70	20	45

# Product range

## Membranpumper og tilbehør

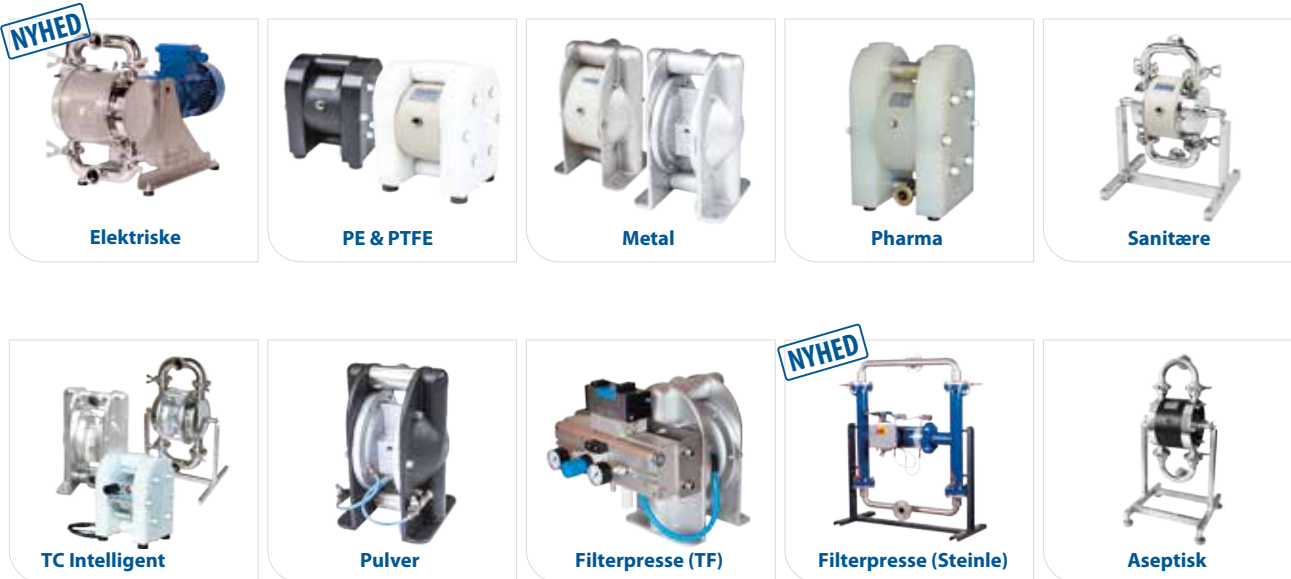

## Slangepumper



## Centrifugalpumper, filterenheder og tilbehør



## Sweden

Filaregatan 4 | S-442 34 Kungälv

Tel: +46 303 63390

Fax: +46 303 19916

E-mail addresses:

Commercial questions: [sales@tapflo.com](mailto:sales@tapflo.com)

Orders: [order@tapflo.com](mailto:order@tapflo.com)

Tech support: [support@tapflo.com](mailto:support@tapflo.com)

## Österreich

Töpferweg 1 | 4320 Perg

Tel: +43 732 272 929 10

Fax: +43 732 272 929 00

E-mail: [sales@tapflo.at](mailto:sales@tapflo.at)

## Tapflo products and services are available worldwide.

Tapflo is represented by own Tapflo Group Companies and carefully selected distributors assuring highest Tapflo service quality for our customers' convenience.

AUSTRALIA | AUSTRIA | AZERBAIJAN | BAHRAIN | BELGIUM | BOSNIA | BRAZIL | BULGARIA | CANADA | CHILE | CHINA | COLOMBIA | CROATIA | CZECH REPUBLIC | DENMARK | ECUADOR | EGYPT | ESTONIA | FINLAND | FRANCE | GEORGIA | GERMANY | GREECE | HONG-KONG | HUNGARY | ICELAND | INDIA | INDONESIA | IRELAND | ISRAEL | ITALY | JAPAN | JORDAN | KAZAKHSTAN | KUWAIT | LATVIA | LIBYA | LITHUANIA | MACEDONIA | MALAYSIA | MEXICO | MONTENEGRO | MOROCCO | NETHERLANDS | NEW ZEALAND | NORWAY | OMAN | PHILIPPINES | POLAND | PORTUGAL | QATAR | ROMANIA | SAUDI ARABIA | SERBIA | SINGAPORE | SLOVAKIA | SLOVENIA | SOUTH AFRICA | SOUTH KOREA | SPAIN | SWEDEN | SWITZERLAND | TAIWAN | THAILAND | TURKEY | UKRAINE | UNITED ARAB EMIRATES | UNITED KINGDOM | USA | UZBEKISTAN | VIETNAM

## Tapflo Group Companies

### Australia

Tapflo Oceania (Pty) Ltd.  
Tel: +61 1800303633  
[sales@tapflo.com.au](mailto:sales@tapflo.com.au)

### China

Tapflo (Wuxi) Pumps Co. Ltd.  
Tel: +86 51082417072  
[sales@tapflo.cn](mailto:sales@tapflo.cn)

### Ireland

Tapflo Ireland Ltd.  
Tel: +353 12011911  
[info@tapflo.ie](mailto:info@tapflo.ie)

### Poland

Tapflo Sp. z o.o.  
Tel: +48 609 995 500  
[info@tapflo.pl](mailto:info@tapflo.pl)

### Spain

Tapflo Ibérica S.L.  
Tel: +34 918093182  
[avives@tapfloiberica.es](mailto:avives@tapfloiberica.es)

### Uzbekistan

Tapflo Uzbekistan  
Tel: +998 712370940  
[sales@tapflo.uz](mailto:sales@tapflo.uz)

### Austria

Tapflo GmbH  
Tel: +43 73227292910  
[sales@tapflo.at](mailto:sales@tapflo.at)

### Croatia

Tapflo d.o.o.  
Tel: +385 914884666  
[sales@tapflo.hr](mailto:sales@tapflo.hr)

### Italy

Tapflo Italia S.r.l.  
Tel: +39 0362306528  
[info@tapfloitalia.com](mailto:info@tapfloitalia.com)

### Qatar

Tapflo Gulf General Trading Co. L.L.C  
Tel: +971 58 582 3630  
[sales@tapfloqulf.com](mailto:sales@tapfloqulf.com)

### South Africa

Tapflo (Pty) Ltd.  
Tel: +27 317015255  
[sales@tapflo.co.za](mailto:sales@tapflo.co.za)

### Bahrain

Tapflo Gulf General Trading Co. L.L.C  
Tel: +971 58 582 3630  
[sales@tapfloqulf.com](mailto:sales@tapfloqulf.com)

### Czech Republic

Tapflo s.r.o.  
Tel: +420 513033920  
[tapflo@tapflo.cz](mailto:tapflo@tapflo.cz)

### Japan

Tapflo Japan K.K.  
Tel: +81 362403510  
[tapflojp@tapflo.co.jp](mailto:tapflojp@tapflo.co.jp)

### Romania

S.C. Tapflo Rom. S.r.l.  
Tel: +40 213451255  
[sales@tapflo.ro](mailto:sales@tapflo.ro)

### Sweden

Tapflo AB  
Tel: +46 (0)30314050  
[info@tapflo.com](mailto:info@tapflo.com)

### Baltic States

Tapflo SIA  
Tel: +371 67472205  
[sales@tapflo.lv](mailto:sales@tapflo.lv)

### Denmark

Tapflo Danmark ApS  
Tel: +45 36454600  
[info@tapflo.dk](mailto:info@tapflo.dk)

### Kazakhstan

Tapflo LLP  
Tel: +7 727 327 83 47  
[sales@tapflo.kz](mailto:sales@tapflo.kz)

### Saudi Arabia

Tapflo Gulf General Trading Co. L.L.C  
Tel: +971 58 582 3630  
[sales@tapfloqulf.com](mailto:sales@tapfloqulf.com)

### Turkey

Tapflo Makina Ltd.  
Tel: +90 2164673311  
[sales@tapflo.com.tr](mailto:sales@tapflo.com.tr)

### Belgium

Tapflo Benelux B.V.  
Tel: +31 (0) 6 21850664  
[info@tapflo.nl](mailto:info@tapflo.nl)

### France

Sarl Tapflo France  
Tel: +33188788240  
[info@tapflo.fr](mailto:info@tapflo.fr)

### Kuwait

Tapflo Gulf General Trading Co. L.L.C  
Tel: +971 58 582 3630  
[sales@tapfloqulf.com](mailto:sales@tapfloqulf.com)

### Serbia

Tapflo d.o.o.  
Tel: +381 21445808  
[sales@tapflo.rs](mailto:sales@tapflo.rs)

### Ukraine

Tapflo LLC  
Tel: +380 442226844  
[sales@tapflo.ua](mailto:sales@tapflo.ua)

### Bulgaria

Tapflo EOOD  
Tel: +359 886 124 937  
[office@tapflo.bg](mailto:office@tapflo.bg)

### Hungary

Tapflo Kft.  
Tel: +36 30148 8551  
[office@tapflo.hu](mailto:office@tapflo.hu)

### Netherlands

Tapflo Benelux B.V.  
Tel: +31 (0) 6 21850664  
[info@tapflo.nl](mailto:info@tapflo.nl)

### Slovakia

Tapflo s.r.o.  
Tel: +421 911137883  
[tapflo@tapflo.sk](mailto:tapflo@tapflo.sk)

### United Arab Emirates

Tapflo Gulf General Trading Co. L.L.C  
Tel: +971 58 582 3630  
[sales@tapfloqulf.com](mailto:sales@tapfloqulf.com)

### Canada

Tapflo Canada  
Tel: +1 514 409 8380  
[office@tapflo.ca](mailto:office@tapflo.ca)

### India

Tapflo Fluid Handling India Pvt Ltd.  
Tel: +91 9028574063  
[enquiry@tapflo.in](mailto:enquiry@tapflo.in)

### Oman

Tapflo Gulf General Trading Co. L.L.C  
Tel: +971 58 582 3630  
[sales@tapfloqulf.com](mailto:sales@tapfloqulf.com)

### Slovenia

Tapflo d.o.o.  
Tel: +386 68613474  
[sales@tapflo.hr](mailto:sales@tapflo.hr)

### United Kingdom

Tapflo (UK) Ltd.  
Tel: +44 2380252325  
[sales@tapflo pumps.co.uk](mailto:sales@tapflo pumps.co.uk)



If your country is not listed please visit [www.tapflo.com/en/contact](http://www.tapflo.com/en/contact)