

tapflo®

# TAPFLO SOLUTIONS™

2025 | 1

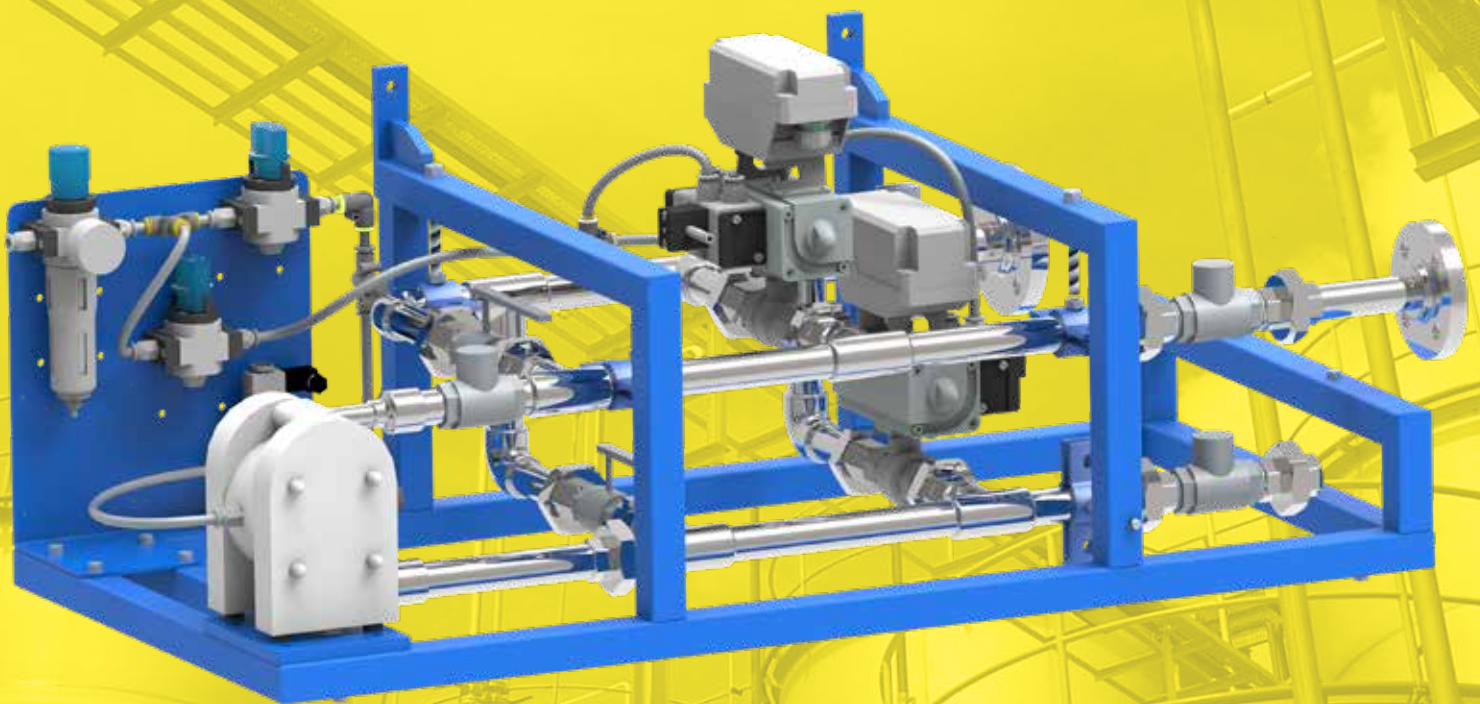

» All about your flow®

[www.tapflo.ca](http://www.tapflo.ca)

## » All about your flow®

*We began our journey in 1980 in Kungälv, a small town on the Swedish west coast, as a family company with an ambition to one day become a global player on the pump market.*

Since the foundation, we have taken pride in delivering a wealth of knowledge and passion for pumps to the industry, whilst supplying a wide range of premium products for various industrial applications.

Over the years, the company has developed into a global Tapflo Group with branches and distributors present in nearly every region of the world.

One thing did not change - we are still a family company.

Our solutions are designed and manufactured in Europe and distributed globally to offer the best service and flow solutions to our customers for a variety of applications.

Our values, Commitment, Quality and Simplicity are reflected both in our product and business approach.



**For fast and flexible service and high-quality products readily available worldwide, choose Tapflo.**

## Quality commitment

At Tapflo we are simply committed to quality. As a result, our production standards, as well as products quality, comply with various globally recognised certification and quality control standards. The Tapflo manufacturing process is certified according to ISO 9001:2015, confirming that our processes are appropriate, effective, customer-focused and continuously improved.



## Tapflo values

Our culture is concluded in Our values

### Commitment

We are different from our competitors because of our willingness to exceed the customers' expectations, move fast and be flexible. Our culture is based on the spirit of togetherness, enthusiasm and integrity. We come from all over the world but we share the same values and we respect each other. We are committed.

### Quality

We understand that the quality in our work is never better than the weakest link, that's why we focus on every small detail. We share a common passion for continuously finding more efficient and effective ways to provide value to our customers. As a manufacturer we have control of the complete process both in terms of our products and the way we operate internally. That is why we manufacture the highest quality pumps in our segment.

### Simplicity

We have a saying, "Simple is art" which means we try to find smooth and uncomplicated solutions in everything. By keeping it simple we can focus on the essential, like designing uncomplicated pumps with few components. For us it is a key to success; strive to simplify what is complex.

# Customised Flow Systems

Reliability and safety are found as the most desired characteristics of devices applied in industrial processes. To meet customers' need, Tapflo offers tailor-made flow systems of the highest quality.

Our mission is to provide technical solutions that guarantee proper functionality and stable operation in every environment.

**Tapflo solutions are successfully applied in the following applications:**

## Industrial sector:

- Chemical processing industry
- Oil & Gas
- Mechanical industry
- Surface treatment
- Pulp & paper industry
- Paint, print & varnish industry
- Waste water treatment



## Hygienic & sanitary sector:

- Food, beverages & drinks
- Dairy, milk & ice cream
- Pharmaceutical industry
- Cosmetics industry
- Processed food



# Tapflo Integrated Solutions

Tapflo offers integrated solutions as an possibility to apply standard devices in non-standard applications.

Combining different flow components into one complex unit is an opportunity to suit individual customers' needs, that are related to:

- » Required equipment & functionality
- » Available space
- » Position of connecting flanges
- » Mobility

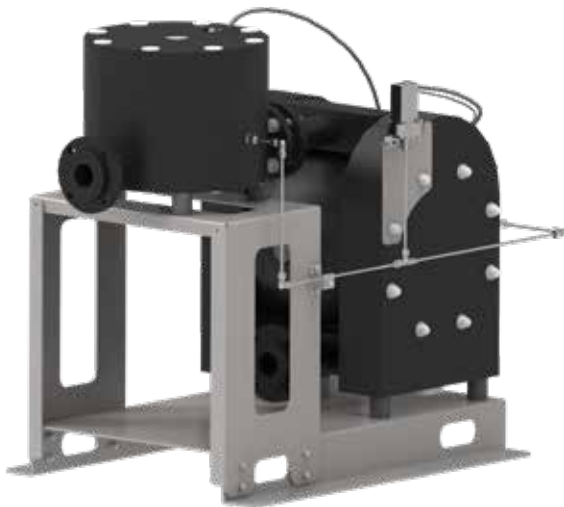

**TXB400+DTBX400:**  
integrated with pneumatic Diaphragm Failure Monitoring System (PDFM).



**T225+DT225:**  
integrated with air pressure booster, built on a hygienic frame.

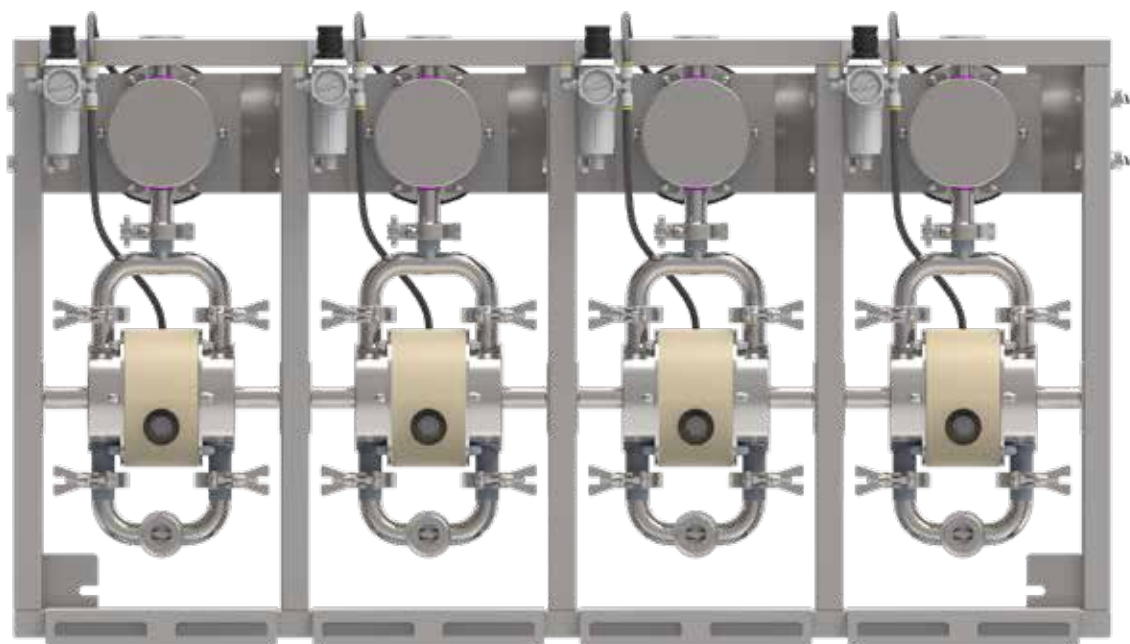

**4x T80+DT80:**  
assembled on a hygienic frame with removable drip pans.

# Tapflo Integrated Solutions



Tapflo biggest pumps & dampeners now available as integrated units!



**T800+DT800 & T820+DT820:** built on one support frame with footprint reduced to less than 0,6 m<sup>2</sup>!

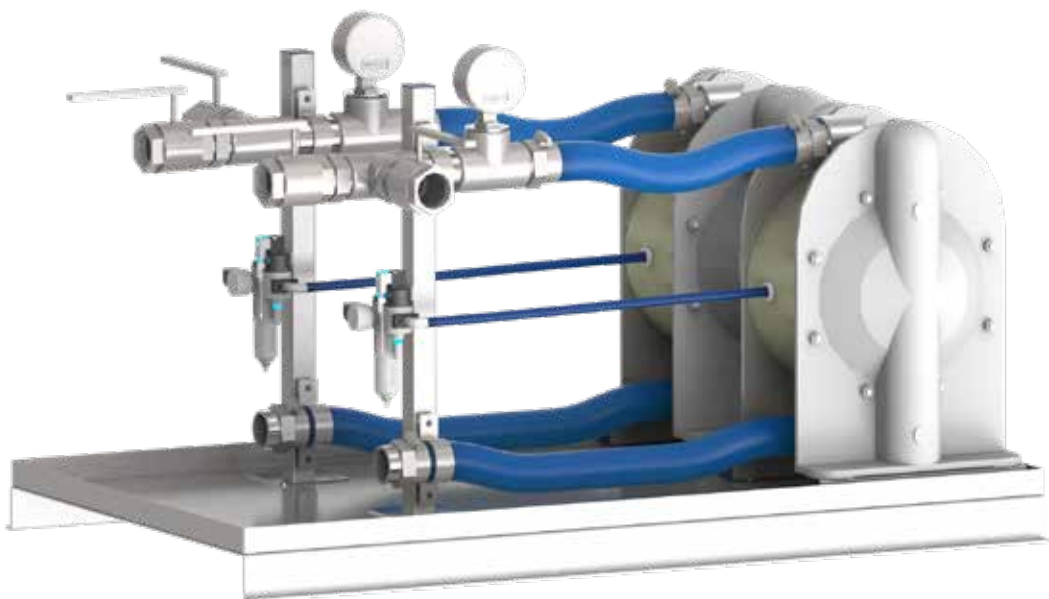

## **2xT420:**

Compact assembly on a support frame with a drip pan.

Ball valves and pressure indicators included to meet customer's needs.

# SKID - Customised Process Units

## Main elements of Tapflo pumping SKID

Every need for a non-standard pumping system is an opportunity for us to create a unique, made-to-measure SKID.

Tapflo Engineering to Order team has developed a complex unloading solution, that is successfully used to unload barrels containing various chemicals. Tapflo AODD pump is a heart of this process.

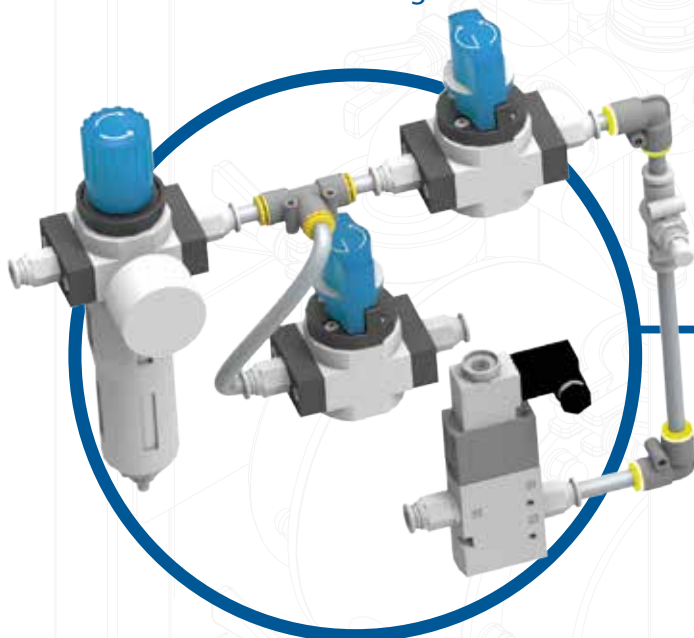

### **Pneumatic or electric control system:**

To optimize the process and have control over it. The pump is stopped after each barrel is emptied. After that the pipelines are flushed with water.



### **Tapflo pump:**

It is the heart of Your process. Tapflo AODD pumps can handle almost every liquid.

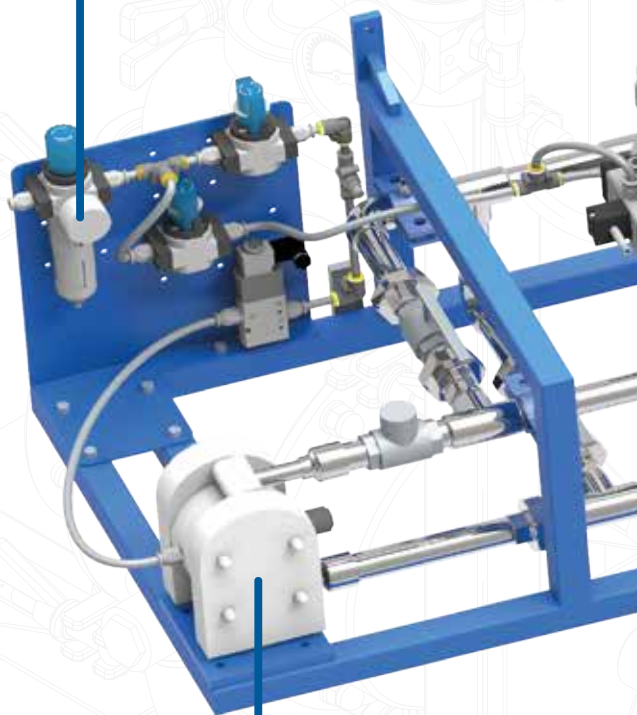

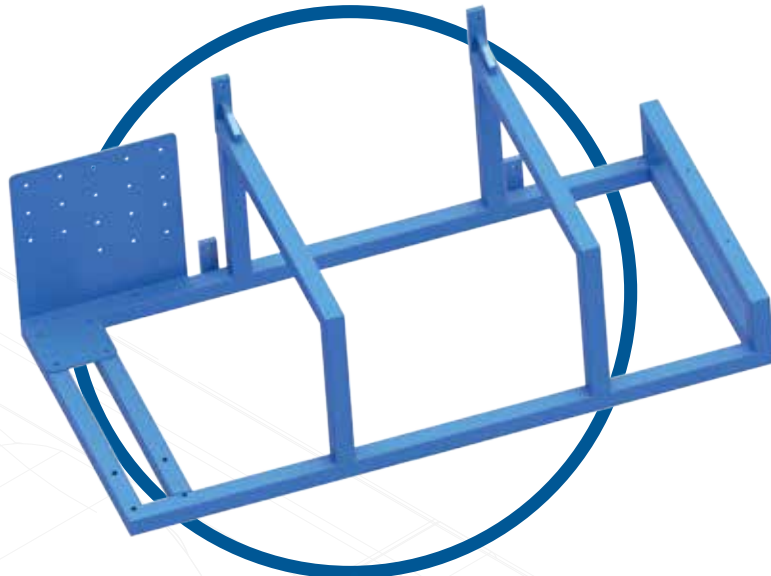

**Support frame:**

To keep the unit steadily and fit it to available space. Both industrial & hygienic standards are available.

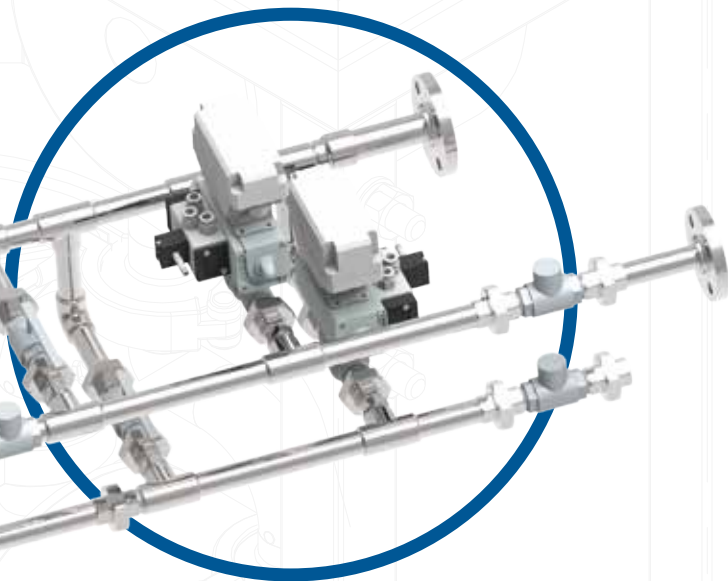
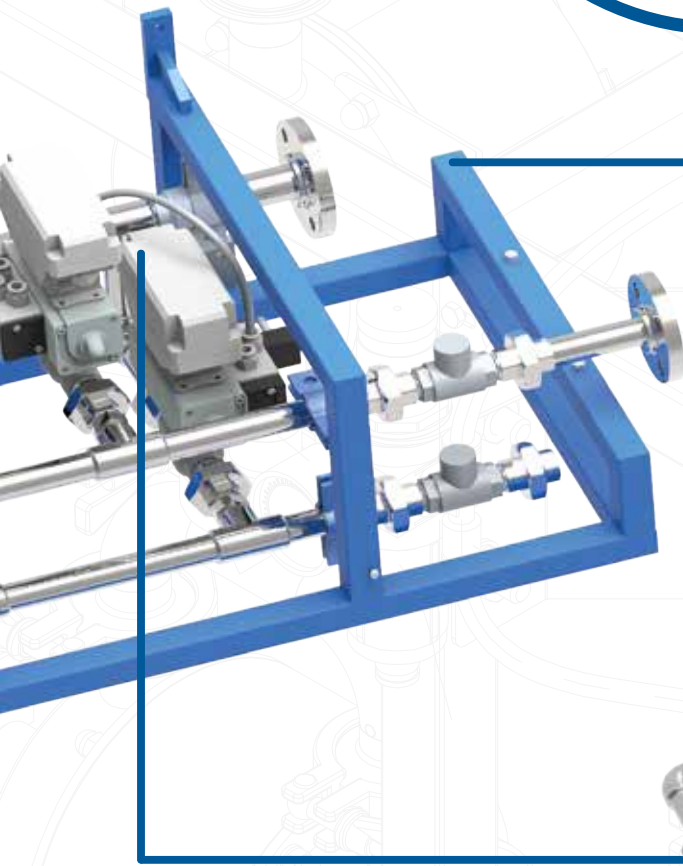

**Control valves & pipelines:**

As we care about proper flow properties, pipelines in every SKID unit are being analyzed and adjusted to obtain the best possible hydraulic conditions.

# SKID - Customised Process Units

## Sample solutions

Based on strong experience in design and production, Tapflo offers wide range of compact process pumping systems.

We create units that are dedicated to certain applications in certain industrial sectors. In Tapflo we provide almost limitless possibilities of pump units' development, both in mechanical & automation disciplines.

In addition, Tapflo might take responsibility for project management, assembly works and integration with existing on site systems.



**"WE WORK IN  
A TURN-KEY  
STANDARD"**

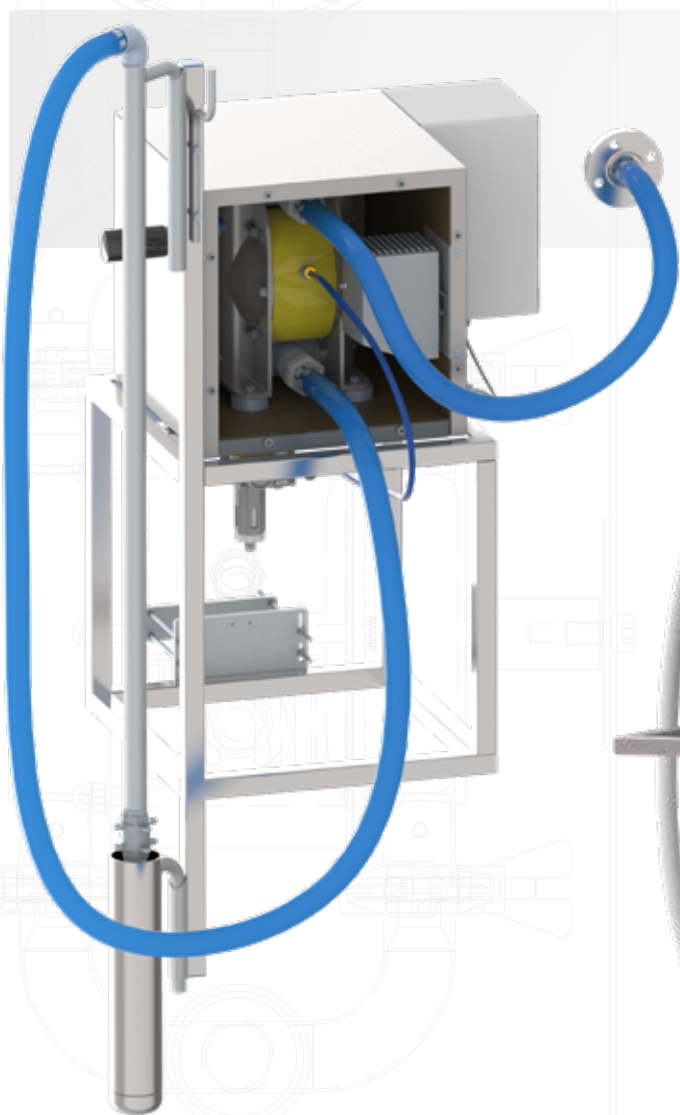

### **IBC containers unloading unit**

Including **Tapflo T120** pump built in a temperature proof box with a control panel. Ready to work in low ambient temperatures.



### **Mobile mixing & unloading tank**

**Tapflo CTV 40-13.5** pump to operate in paint industry.

# SKID - Customised Process Units

## Sample solutions



**"TAPFLO BRINGS  
FUNCTIONALITY"**

**Ethanol dispensing  
and filtering unit:**

**Tapflo TRX20** pump unloading  
a container at pharmaceutical  
factory. ATEX-approved unit.

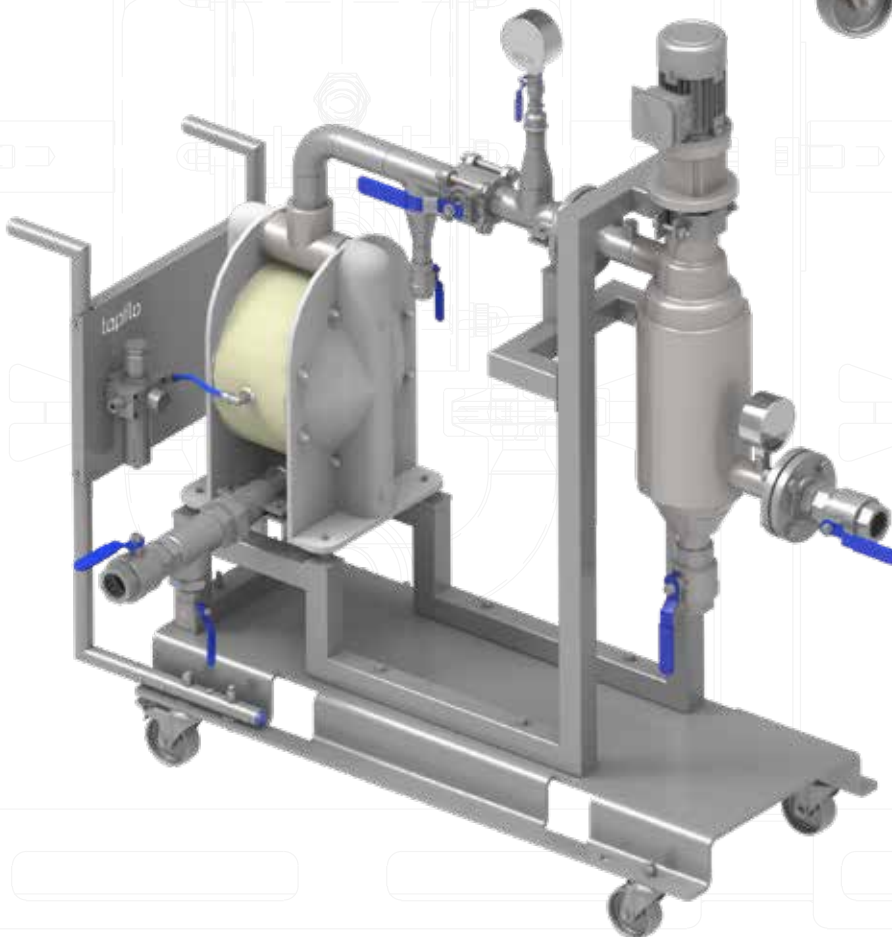

**Mobile filtration unit:**

**Tapflo T420** pump supplying  
paint resin through a self-  
cleaning filter.

# Tapflo Automation & Control Solutions

Tapflo is proud to announce, that we have broadened our offer with automation & control solutions.

By using both pneumatic and electric devices to monitor flow parameters, we are able to ensure safe work of all Tapflo pump units.

## » Air Operated Double Diaphragm Pumps



Pneumatic Diaphragm Failure Monitoring System (**PDFM**)



Pneumatic Dry-Run & Dead Head Protection Systems (**PDRN, PDHR, PDHS**)



Electronic Dry Run & Dead Head protection system (**EDHR**)

## » Centrifugal Pumps

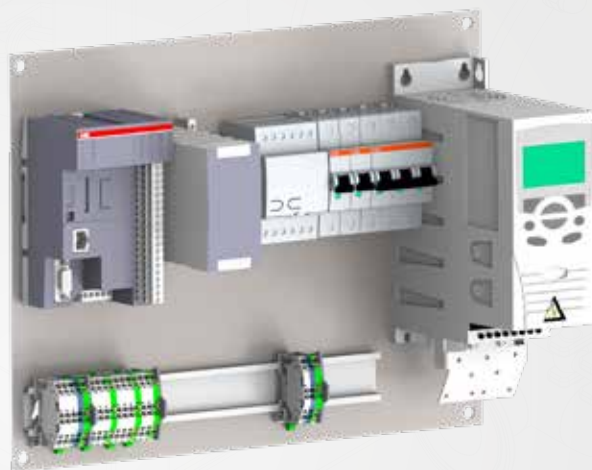











**Stainless and painted steel control cabinets available!**

- » Built-in frequency inverter
- » Start & stop pushbuttons
- » Main switch: padlockable in OFF position for service purpose
- » Configured according to customer's guidelines

# Product range

## Diaphragm pumps

 Electrically operated pumps	 PE & PTFE pumps	 Metal pumps	 Pharmaceutical pumps	 Sanitary pumps
 TC Intelligent pumps	 Powder pumps	 TF Filter press pumps	 Steinle filter press pumps	 Aseptic pumps

## Centrifugal pumps

 CTXH & I, CTH & I pumps	 CTXS H & I, CTS H & I self-priming pumps	 CTV vertical pumps	 CTP plastic pumps	 CTM magnetic drive pumps
--	---	---	---	---

## Other pumps

 Hose pumps	 Submersible pumps	 LPX Lobe pumps*
---	--	--

## Mixers

 Industrial Mixers
---

## Systems

 HVS Quattro Drum Unloading System
--

## Filters

 FT Filter units
--

## Accessories

 Pulsation dampeners	 Control systems	 Hygienic valves	 Hygienic & Industrial Trolleys
--	--	---	---

• offered only in: Australia, Austria, Canada, Denmark, France, Germany, Ireland, Italy, Japan, Netherlands, Portugal, South Africa, Spain, Sweden, United Kingdom

## Canada

101-43 Keefer Crt | Hamilton, ON

Tel: +1 514 409 8380

E-mail address: [office@tapflo.ca](mailto:office@tapflo.ca)

## Tapflo products and services are available worldwide.

Tapflo is represented by own Tapflo Group Companies and carefully selected distributors assuring highest Tapflo service quality for our customers' convenience.

AUSTRALIA | AUSTRIA | AZERBAIJAN | BAHRAIN | BELGIUM | BOSNIA | BRAZIL | BULGARIA | CANADA | CHILE | CHINA | COLOMBIA | CROATIA | CZECH REPUBLIC | DENMARK | ECUADOR | EGYPT | ESTONIA | FINLAND | FRANCE | GEORGIA | GERMANY | GREECE | HONG-KONG | HUNGARY | ICELAND | INDIA | INDONESIA | IRELAND | ISRAEL | ITALY | JAPAN | JORDAN | KAZAKHSTAN | KUWAIT | LATVIA | LIBYA | LITHUANIA | MACEDONIA | MALAYSIA | MEXICO | MONTENEGRO | MOROCCO | NETHERLANDS | NEW ZEALAND | NORWAY | OMAN | PHILIPPINES | POLAND | PORTUGAL | QATAR | ROMANIA | SAUDI ARABIA | SERBIA | SINGAPORE | SLOVAKIA | SLOVENIA | SOUTH AFRICA | SOUTH KOREA | SPAIN | SWEDEN | SWITZERLAND | TAIWAN | THAILAND | TURKEY | UKRAINE | UNITED ARAB EMIRATES | UNITED KINGDOM | USA | UZBEKISTAN | VIETNAM

## Tapflo Group Companies

### Australia

Tapflo Oceania (Pty) Ltd.  
Tel: +61 1800303633  
[sales@tapflo.com.au](mailto:sales@tapflo.com.au)

### China

Tapflo (Wuxi) Pumps Co. Ltd.  
Tel: +86 51082417072  
[sales@tapflo.cn](mailto:sales@tapflo.cn)

### Ireland

Tapflo Ireland Ltd.  
Tel: +353 12011911  
[info@tapflo.ie](mailto:info@tapflo.ie)

### Poland

Tapflo Sp. z o.o.  
Tel: +48 609 995 500  
[info@tapflo.pl](mailto:info@tapflo.pl)

### Spain

Tapflo Ibérica S.L.  
Tel: +34 918093182  
[avives@tapfloiberica.es](mailto:avives@tapfloiberica.es)

### Uzbekistan

Tapflo Uzbekistan  
Tel: +998 712370940  
[sales@tapflo.uz](mailto:sales@tapflo.uz)

### Austria

Tapflo GmbH  
Tel: +43 73227292910  
[sales@tapflo.at](mailto:sales@tapflo.at)

### Croatia

Tapflo d.o.o.  
Tel: +385 914884666  
[sales@tapflo.hr](mailto:sales@tapflo.hr)

### Italy

Tapflo Italia S.r.l.  
Tel: +39 0362306528  
[info@tapfloitalia.com](mailto:info@tapfloitalia.com)

### Qatar

Tapflo Gulf General Trading Co. L.L.C  
Tel: +971 58 582 3630  
[sales@tapfloqulf.com](mailto:sales@tapfloqulf.com)

### South Africa

Tapflo (Pty) Ltd.  
Tel: +27 317015255  
[sales@tapflo.co.za](mailto:sales@tapflo.co.za)

### Bahrain

Tapflo Gulf General Trading Co. L.L.C  
Tel: +971 58 582 3630  
[sales@tapfloqulf.com](mailto:sales@tapfloqulf.com)

### Czech Republic

Tapflo s.r.o.  
Tel: +420 513033920  
[tapflo@tapflo.cz](mailto:tapflo@tapflo.cz)

### Japan

Tapflo Japan K.K.  
Tel: +81 362403510  
[tapflojp@tapflo.co.jp](mailto:tapflojp@tapflo.co.jp)

### Romania

S.C. Tapflo Rom. S.r.l.  
Tel: +40 213451255  
[sales@tapflo.ro](mailto:sales@tapflo.ro)

### Sweden

Tapflo AB  
Tel: +46 (0)30314050  
[info@tapflo.com](mailto:info@tapflo.com)

### Baltic States

Tapflo SIA  
Tel: +371 67472205  
[sales@tapflo.lv](mailto:sales@tapflo.lv)

### Denmark

Tapflo Danmark ApS  
Tel: +45 36454600  
[info@tapflo.dk](mailto:info@tapflo.dk)

### Kazakhstan

Tapflo LLP  
Tel: +7 727 327 83 47  
[sales@tapflo.kz](mailto:sales@tapflo.kz)

### Saudi Arabia

Tapflo Gulf General Trading Co. L.L.C  
Tel: +971 58 582 3630  
[sales@tapfloqulf.com](mailto:sales@tapfloqulf.com)

### Turkey

Tapflo Makina Ltd.  
Tel: +90 2164673311  
[sales@tapflo.com.tr](mailto:sales@tapflo.com.tr)

### Belgium

Tapflo Benelux B.V.  
Tel: +31 (0) 6 21850664  
[info@tapflo.nl](mailto:info@tapflo.nl)

### France

Sarl Tapflo France  
Tel: +33188788240  
[info@tapflo.fr](mailto:info@tapflo.fr)

### Kuwait

Tapflo Gulf General Trading Co. L.L.C  
Tel: +971 58 582 3630  
[sales@tapfloqulf.com](mailto:sales@tapfloqulf.com)

### Serbia

Tapflo d.o.o.  
Tel: +381 21445808  
[sales@tapflo.rs](mailto:sales@tapflo.rs)

### Ukraine

Tapflo LLC  
Tel: +380 442226844  
[sales@tapflo.ua](mailto:sales@tapflo.ua)

### Bulgaria

Tapflo EOOD  
Tel: +359 886 124 937  
[office@tapflo.bg](mailto:office@tapflo.bg)

### Hungary

Tapflo Kft.  
Tel: +36 30148 8551  
[office@tapflo.hu](mailto:office@tapflo.hu)

### Netherlands

Tapflo Benelux B.V.  
Tel: +31 (0) 6 21850664  
[info@tapflo.nl](mailto:info@tapflo.nl)

### Slovakia

Tapflo s.r.o.  
Tel: +421 911137883  
[tapflo@tapflo.sk](mailto:tapflo@tapflo.sk)

### United Arab Emirates

Tapflo Gulf General Trading Co. L.L.C  
Tel: +971 58 582 3630  
[sales@tapfloqulf.com](mailto:sales@tapfloqulf.com)

### Canada

Tapflo Canada  
Tel: +1 514 409 8380  
[office@tapflo.ca](mailto:office@tapflo.ca)

### India

Tapflo Fluid Handling India Pvt Ltd.  
Tel: +91 9028574063  
[enquiry@tapflo.in](mailto:enquiry@tapflo.in)

### Oman

Tapflo Gulf General Trading Co. L.L.C  
Tel: +971 58 582 3630  
[sales@tapfloqulf.com](mailto:sales@tapfloqulf.com)

### Slovenia

Tapflo d.o.o.  
Tel: +386 68613474  
[sales@tapflo.hr](mailto:sales@tapflo.hr)

### United Kingdom

Tapflo (UK) Ltd.  
Tel: +44 2380252325  
[sales@tapflo pumps.co.uk](mailto:sales@tapflo pumps.co.uk)



If your country is not listed please visit [www.tapflo.com/en/contact](http://www.tapflo.com/en/contact)