

SLES Mixing and Dilution Unit

SLES* is an organic chemical compound with excellent cleansing and foaming properties. For this reason it is **an ingredient of various detergents, household products, soaps and shampoos.**

SLES is usually supplied to the producers of above liquids at a concentration of 70%.

Due to its physical properties, this concentrated solution is difficult to handle and must be diluted below 27% before using it in the process.

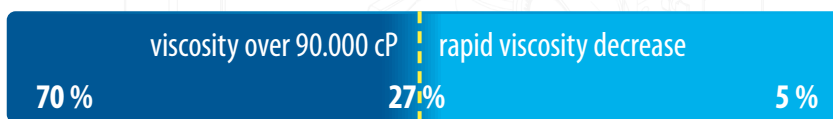

Solution concentration

The innovative SLES Mixing and Dilution Unit designed by Tapflo enables an **immediate and precise** preparation of a less concentrated SLES solution. This device gives a full control over the process of dilution, providing SLES that is **homogenous and stable** over time.

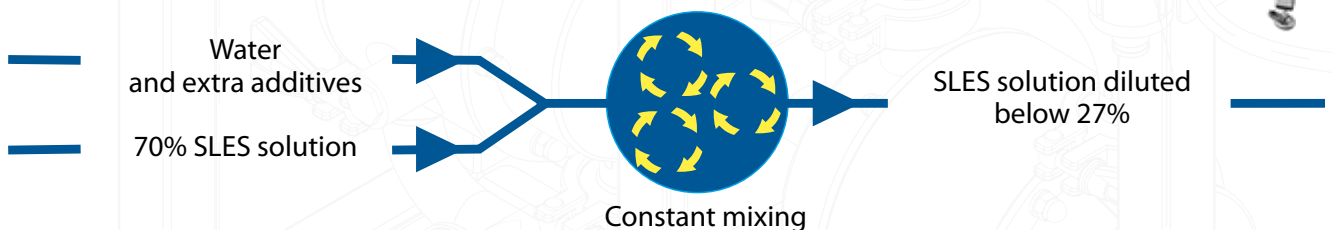

Features

- ✓ **Continuous or batch supply** of SLES solution at a given concentration
- ✓ **Immediate start** of mixing process
- ✓ **Constant tracing and recording** of operation parameters
- ✓ **Small in size**, lightweight and well thought-out construction
- ✓ **Local or remote control** over the Unit
- ✓ **Possible extensions:**
 - dosing of additional ingredients
 - feeding 70% SLES solution directly from a road tanker

Benefits

- ✓ **Independence** from deliveries of diluted SLES
- ✓ **Flexibility and continuity** of production
- ✓ **High quality** of the on-site prepared SLES solution
- ✓ **Significant costs reduction** of SLES purchase, transportation and storage
- ✓ **Additional savings** on the warehouse space
- ✓ **Simple and user-friendly** control system

*SLES - sodium laureth sulfate

Design and materials

Pumps:	<ul style="list-style-type: none"> • Progressive Cavity Pump for 70% SLES solution feed • Centrifugal Pump for mixing SLES with water and pumping the solution
Control and automation:	<ul style="list-style-type: none"> • Control Unit including PLC with a touch screen • Pressure transmitters • Temperature transmitter • Frequency inverters • Flowmeters • Valves with dedicated control system
Piping:	<ul style="list-style-type: none"> • AISI 316 stainless steel
Frame:	<ul style="list-style-type: none"> • AISI 304 stainless steel

Technical data

Flow rate (SLES solution):	up to 30 m ³ /h, various sizes available
Discharge pressure:	up to 6 bar-g
Concentration of obtained SLES solution:	0 - 27 %

Dimensions

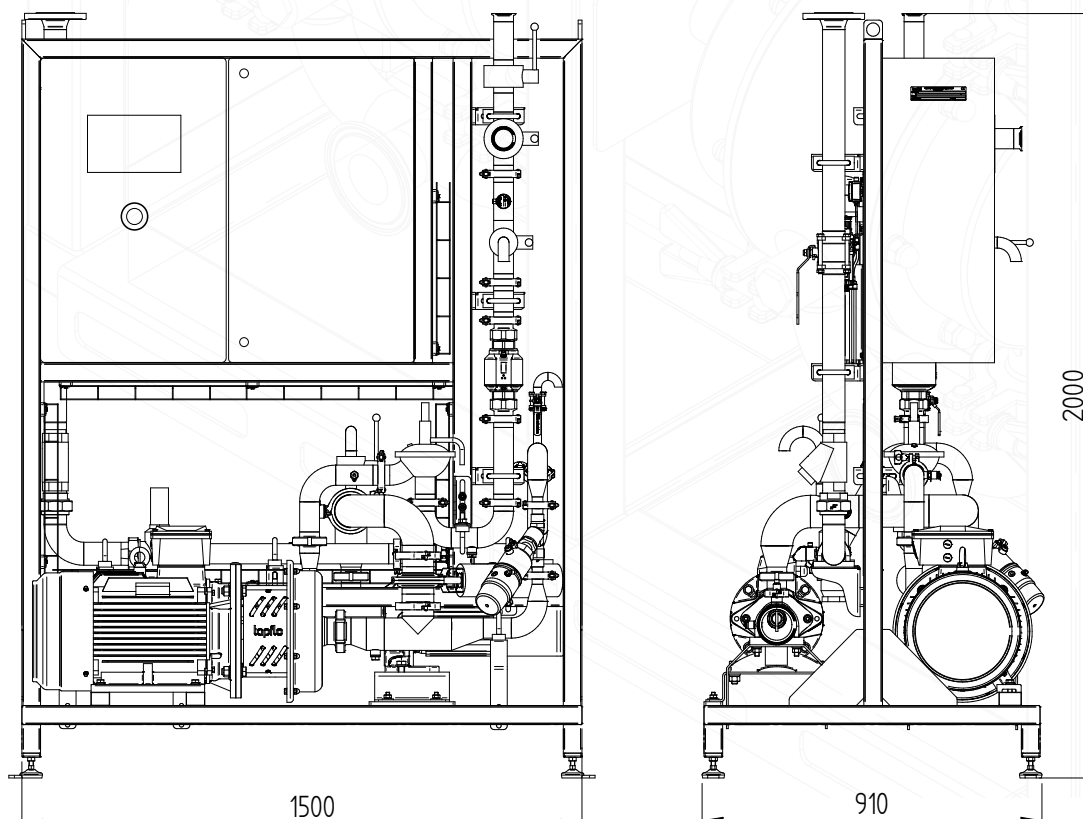

* Dimensions of 5 m³/h flow rate unit