



WE  
PUMP  
YOUR  
CHEMICALS



# UCL SERIES

LINED - MECHANICAL SEAL  
CENTRIFUGAL PUMP

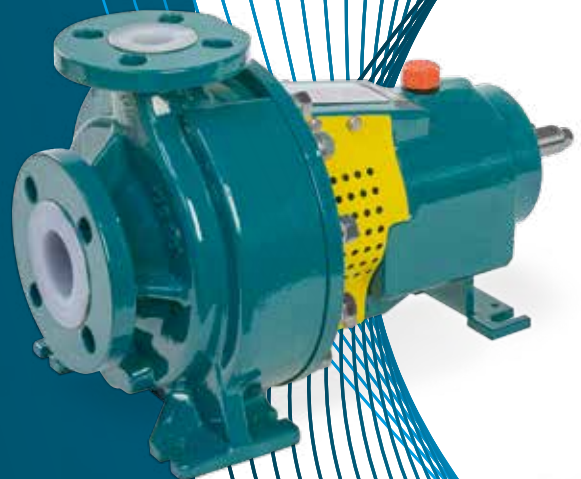

## UCL-B

### Close coupled version with B5 motors

#### Range of applications

- \_ Fine chemicals operating 24 hours a day
- \_ Basic chemicals operating 24 hours a day
- \_ Agrochemicals and fertilizers
- \_ Pharmaceutical industries (API)
- \_ Air treatment / scrubber
- \_ Wastewater treatment

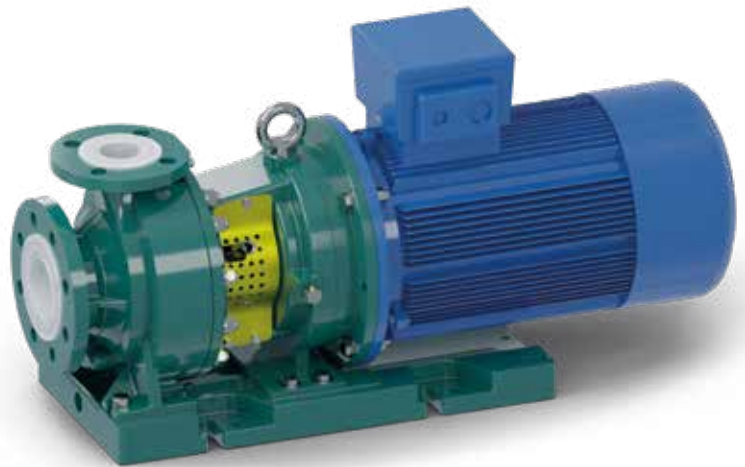

in compliance with:  
2006/42/CE



ATEX 100  
Directive: 2014/34/EU



## Open impeller and mechanical seal

In all those cases where the process fluid is dangerous, corrosive and toxic containing suspended solids it is possible to use this type of centrifugal pump.

Here are the three main advantages:

- \_ Lined construction: metal materials lined in PP, PVDF, PFA;
- \_ Closed or open radial impeller lined in PP, PVDF, PFA;
- \_ Single or double mechanical seals with integral SiC faces.



# UCL

## Bare shaft «back pull out» version with B3 motors



## R&D with Fluidodynamic Simulation

Designed with an innovative simulation software, that permits to obtain high hydraulic performances and efficiency levels near to the physical possible values.

Simulated with **Ansys**

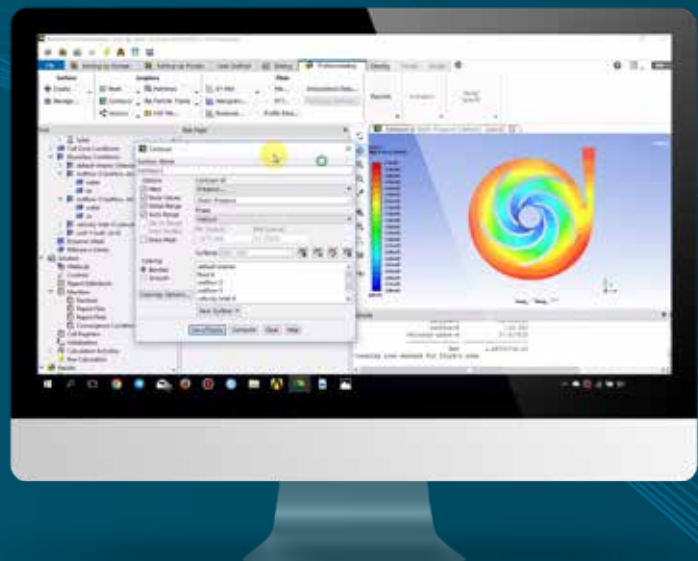

\*All Ansys, Inc. brand, product, logos are registered trademarks or trademarks of Ansys, Inc.

# UCL Series Main features and 3d view

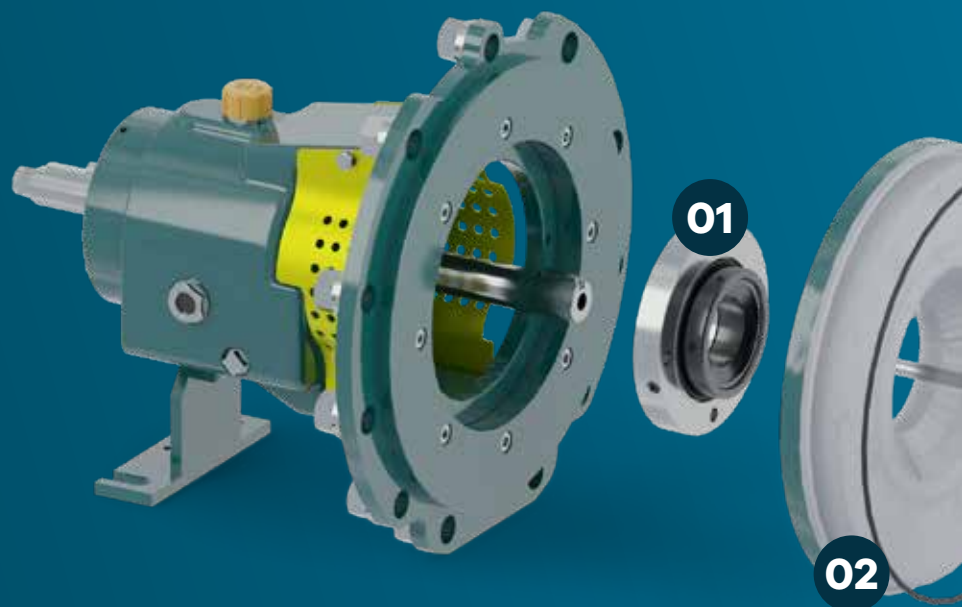

## 01. Seal

On the UCL range it is possible to install single and double cartridge mechanical seals, where requested it is possible to install mechanical seals from various manufacturers

## 02. Stuffing box

The cast iron stuffing box is lined with PP, PVDF, PFA by Transfer Moulding. The large stuffing box is equipped with flow-breaking ribs. The conical shape guarantees the removal of solids from the seal area.

## 03. Shaft and shaft sleeve

The shaft and shaft sleeve are made in 2 separate pieces. In this way, in the event of failure of the mechanical seal, the replacement of the impeller can be avoided because it is separated from the sleeve (reduction in repair costs).

## 04. Impeller

The lining on a metal core made by transfer moulding ensures excellent mechanical and chemical resistance.

## 05. Casing

The spheroidal cast iron casing lined in PP, PVDF and PFA guarantees excellent mechanical resistance even in the event of vibrations, expansion and stresses induced by the pipes as well as allowing vacuum operation. Self-venting thanks to discharge nozzle on the top. Optional drained casing.



### CLOSED IMPELLER

---

Closed impellers are suitable for clean liquids. The hydraulic efficiency is good and there is no recirculation of liquid within impeller blades.



### RADIAL OPEN IMPELLER

---

The radial open impeller is suitable for solutions with suspended solids. The low hydraulic efficiency is caused by the high recirculation of liquid within impeller blades.



### LINED SHAFT SLEEVE

---

The impeller and shaft sleeve are made of 2 separate pieces: in this way, in the event of failure of the mechanical seal, only the shaft sleeve will need to be replaced.

The seal between the shaft sleeve and the impeller is guaranteed by a pressure locking system ("push-in" design).

All parts in contact with the liquid are lined in PFA and SiC silicon carbide.

To avoid unscrewing the impeller - shaft (even in the event of reverse rotation of the pump during start-up), a key has been introduced.

The shaft sleeve is lined in PFA, however its specific design also allows construction in alternative materials (e.g. Hastelloy C)

An O-Ring ensures the seal between the rear side of the impeller and the shaft.



### SHAFT

---

The special design of the shaft guarantees no weak point that could cause leakage; the impeller is fixed on the shaft with a long screw that pass through the shaft.

The rigidity of the shaft (flexion < 0.05mm) improves the life of the mechanical seal.

Standard 400 series stainless steel shaft (1.4057) provides reliable power transmission and corrosion resistance at both the pump and coupling ends.



# Bearing support for bare-shaft operation

## SUPPORT

New bearing support: the greater quantity of oil guarantees better lubrication.

- \_ Breather cap for filling oil from above
- \_ Oil sight glass to better check the level
- \_ Increased drainage hole

The support can mount 2 different types of bearing protection:

- \_ Standard oil seal
- \_ Non-contact labyrinth seal

Oiler to maintain constant oil level (optional)

## BEARINGS

L10 life class ball bearings suitable for operation for 17,500 hours (not more than 125% of QBEP).

Front bearing (impeller side): cylindrical bearings with high radial load.

Rear bearing (motor side): High axial load angular contact ball bearings.

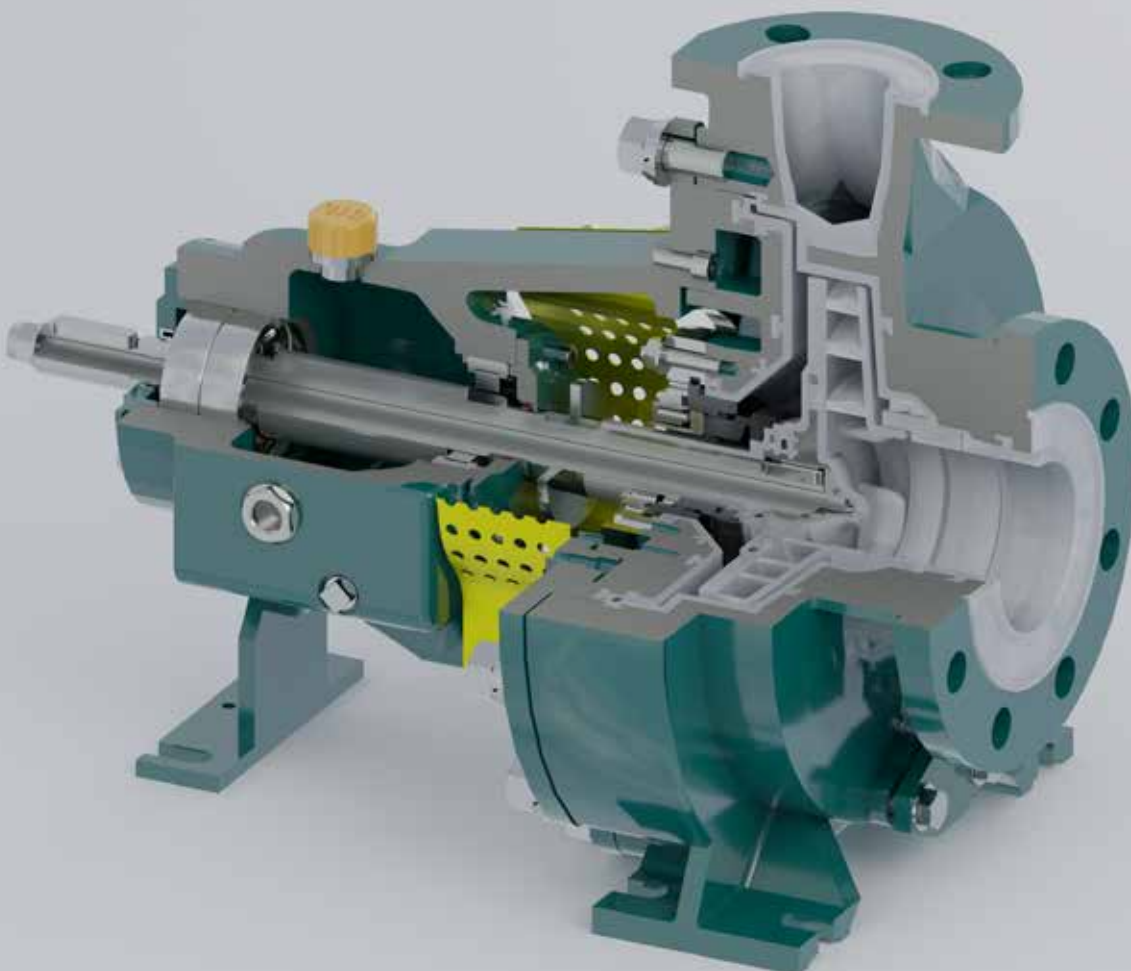

# Mechanical seal

## CSS35Q

### Single internal mechanical seal - tapered stuffing box

CSS35Q single seal with water "quench" (washing): useful in case of solutions that tend to crystallize in contact with air.

Also available in the version with grease quench: for all those applications in which external seal cleaning cannot be carried out with water (such as for example with H<sub>2</sub>SO<sub>4</sub>).

#### Faces sealed in diamond sic

- \_ Low coefficient of friction and heat generation, even when lubrication is insufficient or in dry running conditions
- \_ Increased pump service life
- \_ Low wear of the diamond coating
- \_ Significant energy savings



## CSS

### Single internal mechanical seal - tapered stuffing box

---

- \_ Suitable for pumping corrosive liquids with medium/low solids content
- \_ Easy maintenance thanks to the cartridge seal-like design
- \_ SiC faces resistant to abrasion
- \_ No metallic component is in contact with the pumped liquid



### Faces sealed in diamond sic

- \_ Low coefficient of friction and heat generation, even when lubrication is insufficient or in dry running conditions
- \_ Increased pump service life
- \_ Low wear of the diamond coating
- \_ Significant energy savings

## CDC

### Double cartridge mechanical seal - tapered stuffing box

---

The CDC is suitable for applications with:

- \_ dangerous, toxic and flammable liquids, where no seepage into the environment is tolerated
- \_ liquids containing abrasive solids
- \_ organic solutions of polymers in suspension, where cooling of the seal is critical
- \_ liquids in batch processes (low flow rates) and/or where transients may occur in the absence of liquid (e.g. cavitation)

Other mechanical seals can be adapted on UCL pumps, from single seal up to double back-to-back cartridge sealing system



# Performance Curves Impeller closed

50 Hz

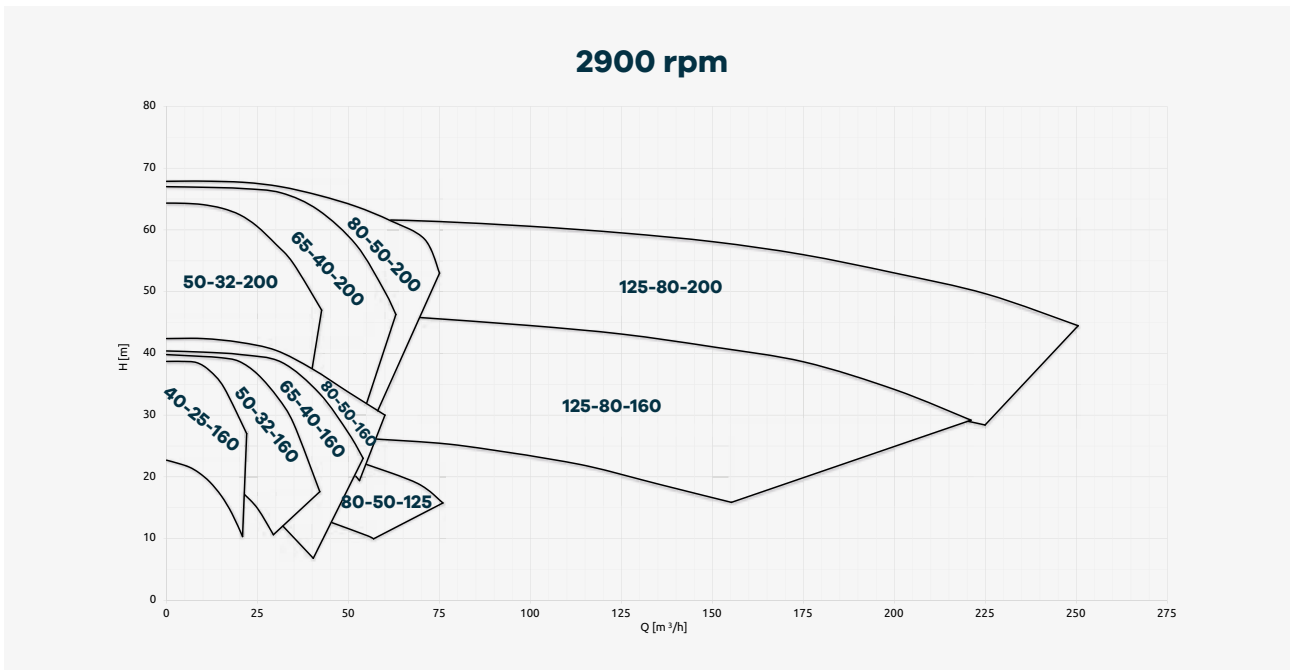
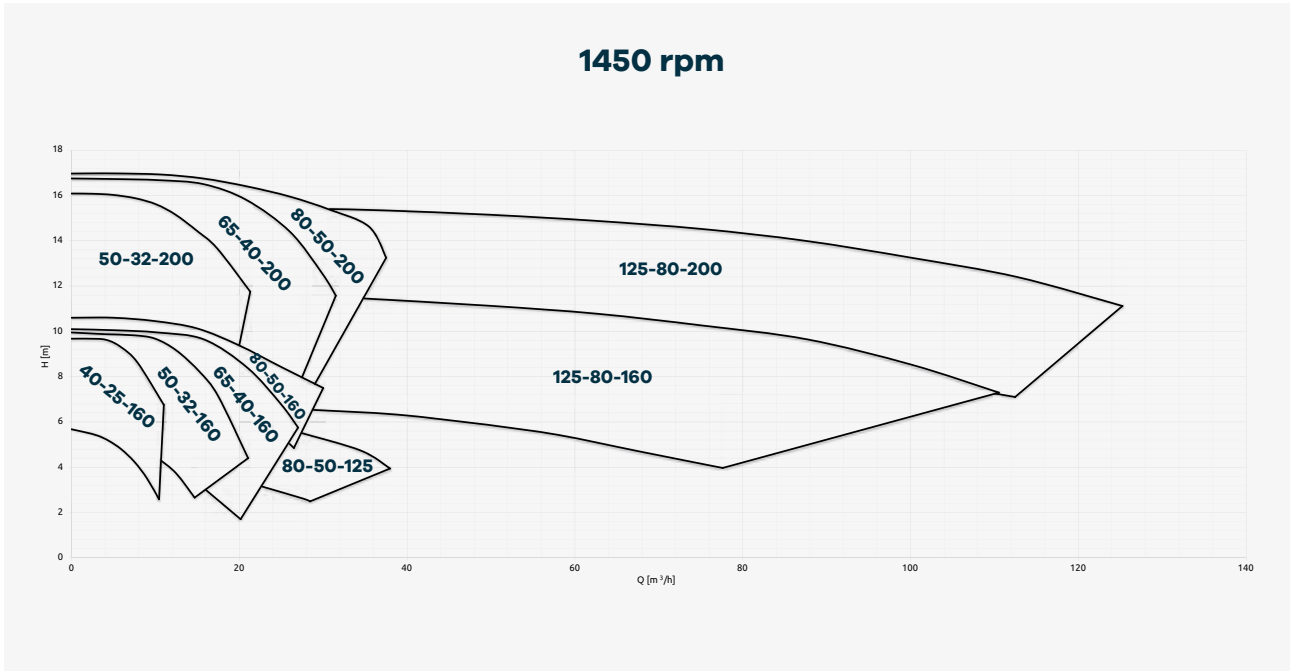

Not binding data refers to water at room temperature.  
For specific performance curve contact CDR Pompe S.R.L.

## 60 Hz

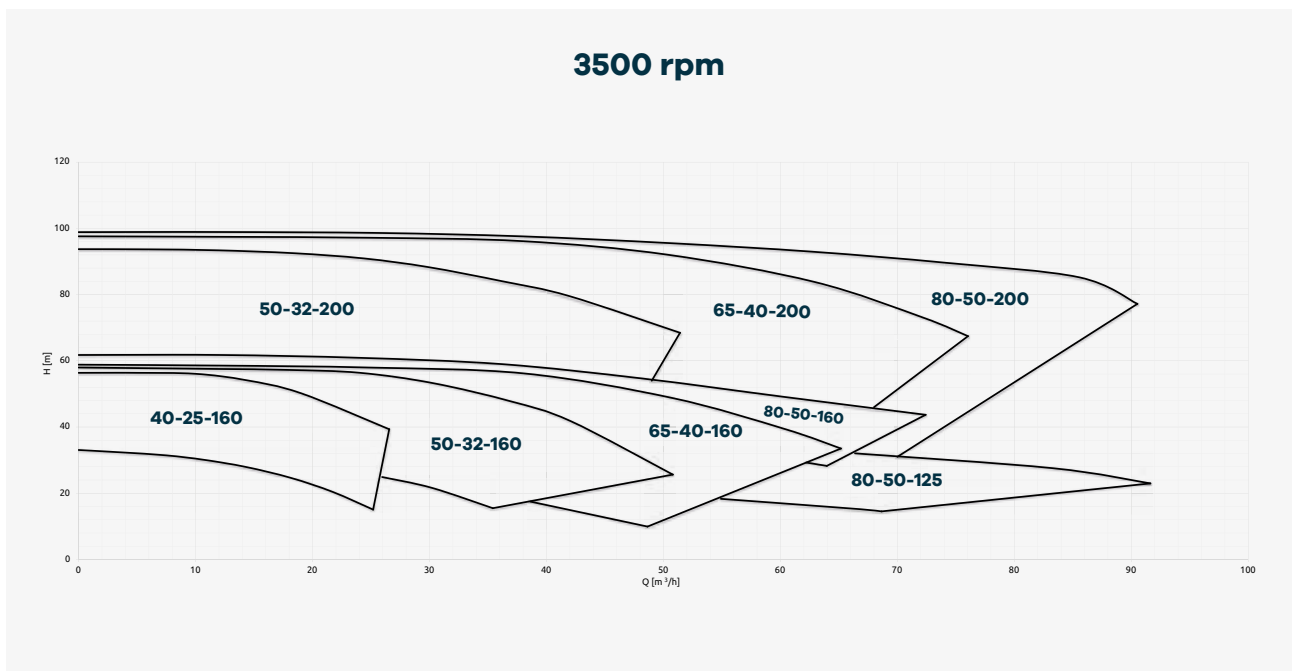
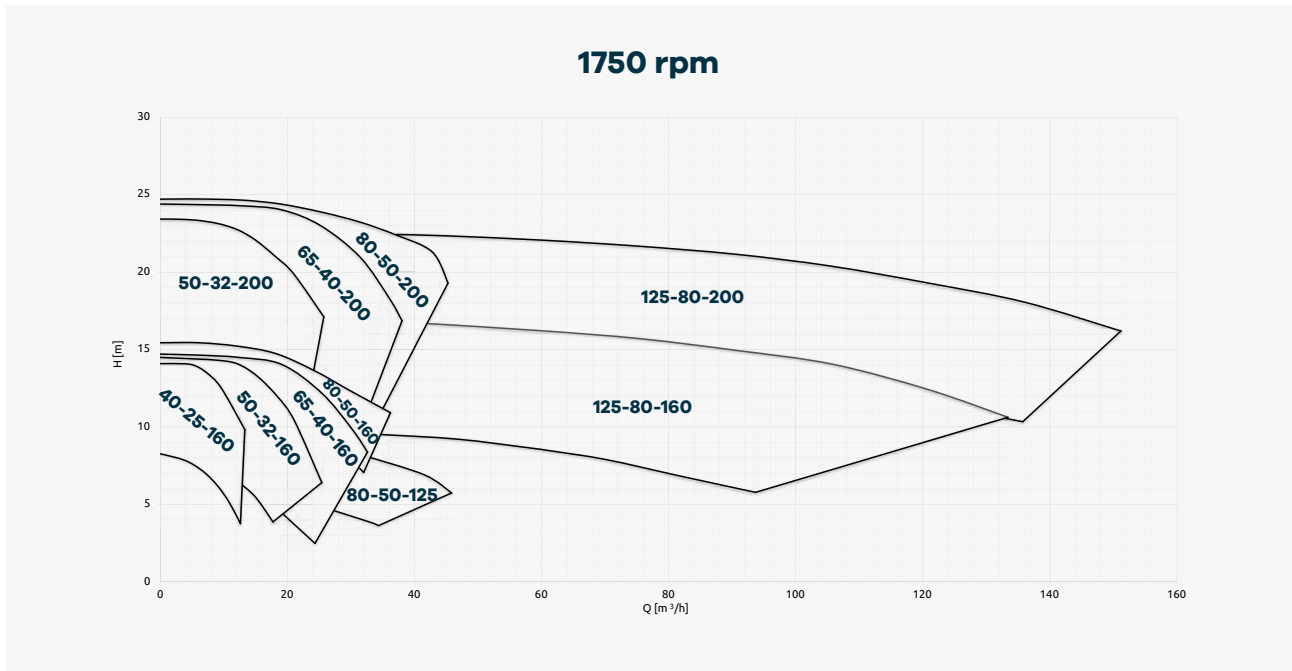

# Performance Curves Radial impeller

50 Hz

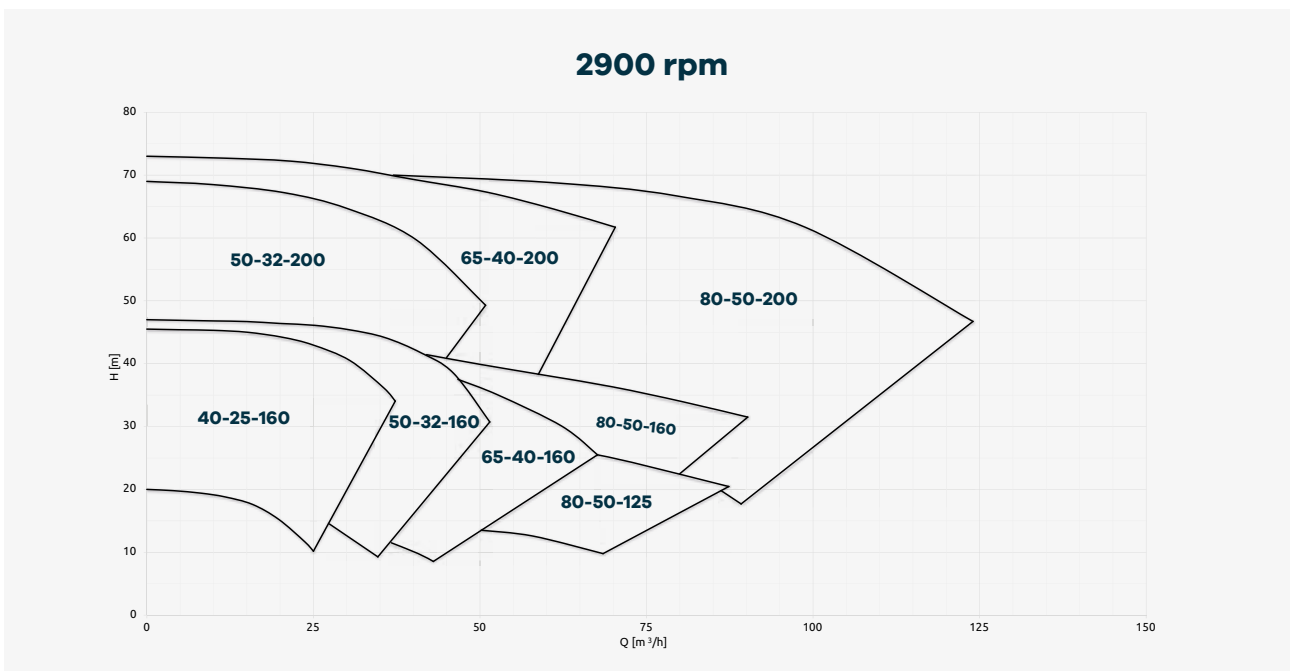
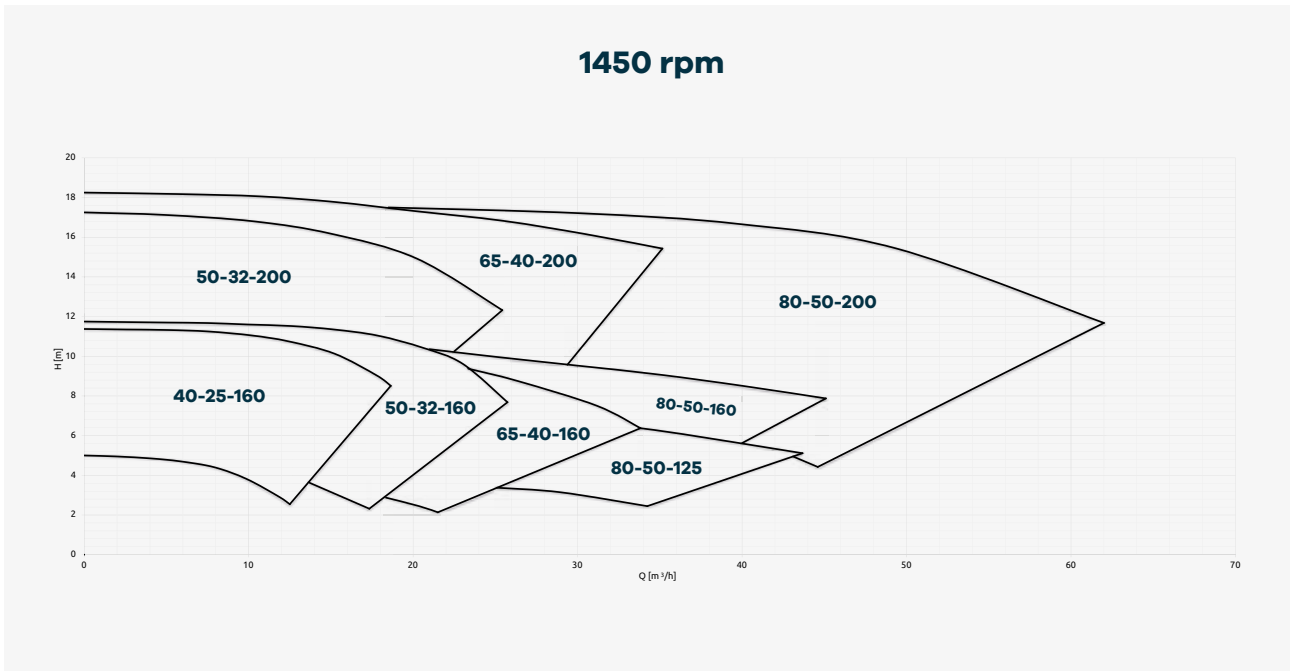

Not binding data refers to water at room temperature.  
For specific performance curve contact CDR Pompe S.R.L.

## 60 Hz

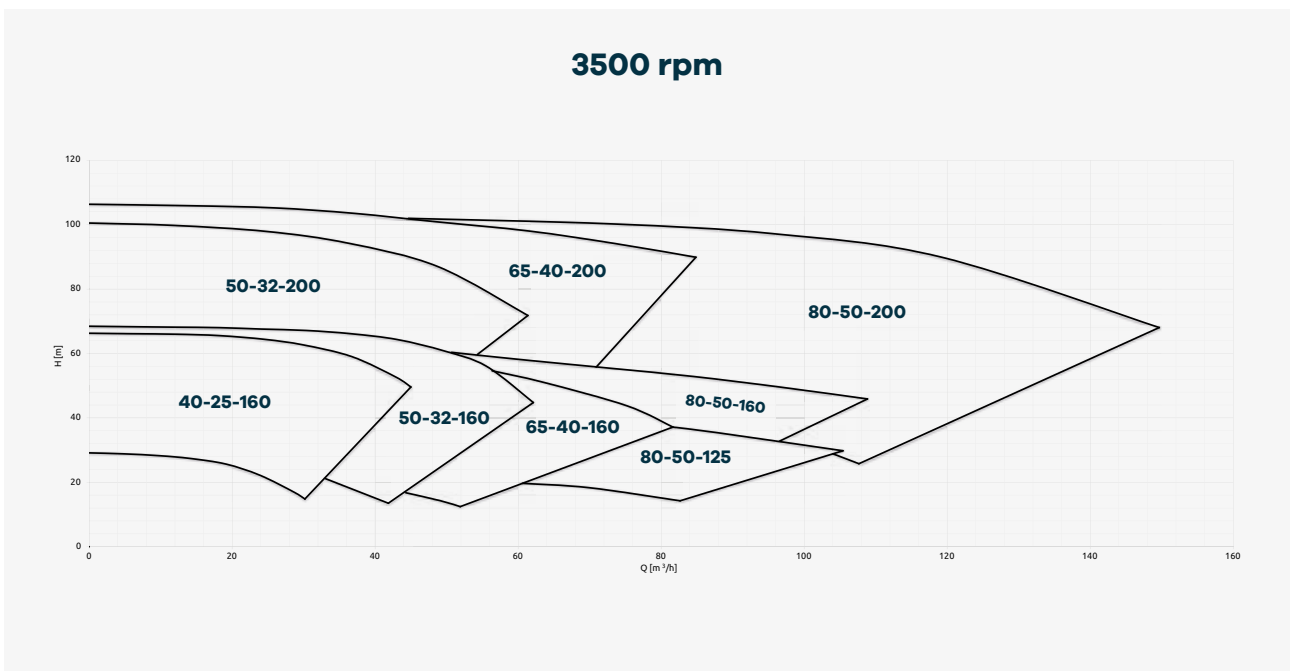
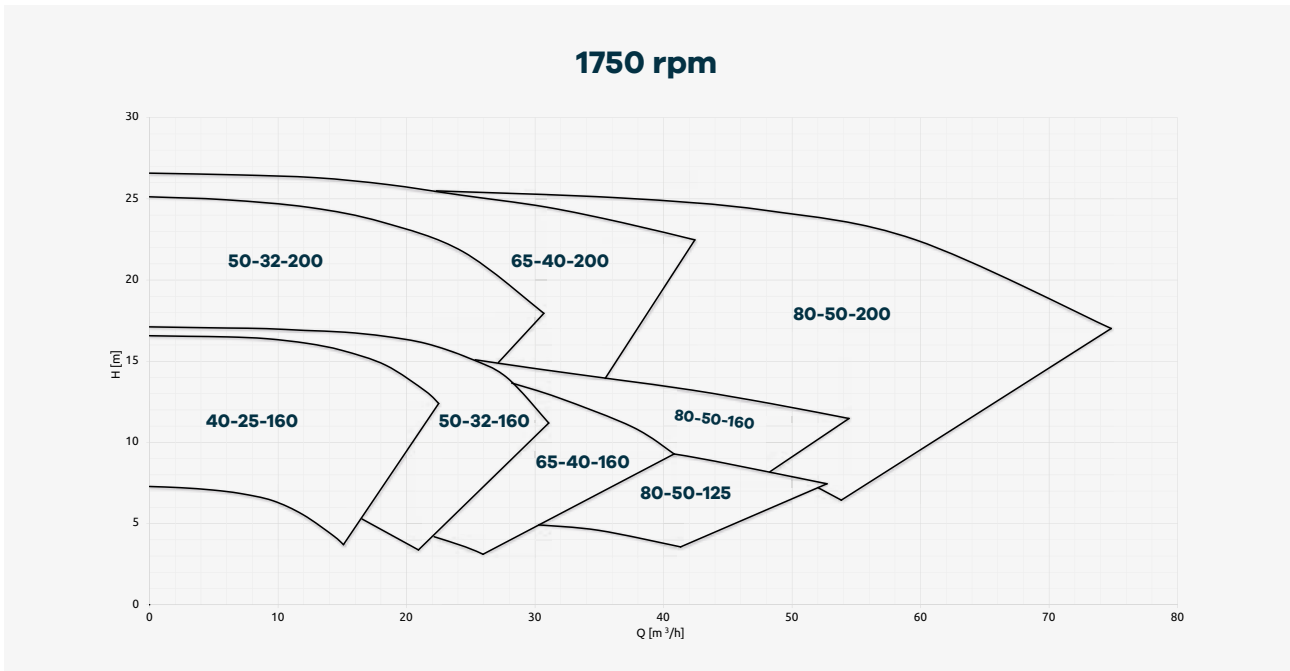

# UCL

## Overall dimensions

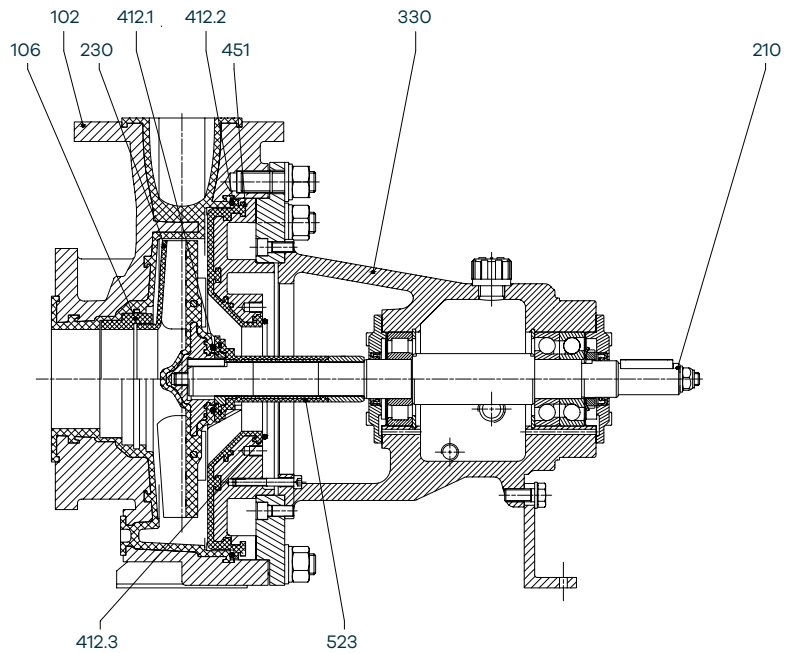

### Technical specifications

**Performance at 2900 rpm**

Q max = 250 m<sup>3</sup>/h  
H max = 75 m

**Motors**

UCL : 1,1 kW (motor size 80) > 55 kW (motor size 250)  
UCL-B : 1,1 kW (motor size 90) > 18.5 kW (motor size 160)

**Allowable temperatures**

PP : -10 °C > +70 °C  
PVDF : -30 °C > +100 °C  
PFA : -50 °C > +140 °C

**Allowable pressures**

PN16 (20 °C)

**Flange Connections**

UNI 1092-2 / ISO 7005-2 PN 16, type B  
slotted ANSI 150

**Viscosity**

min: 0,5 cSt  
max: 180 cSt

**Allowable solids**

Max size: 1,5 mm

### Internal components

DIN	Components	Materials
102	Casing	PP lined \ PVDF lined \ PFA lined
106	Suction Casing	PFA
210	Axle	Aisi 431
230	Impeller	PP lined \ PVDF lined \ PFA lined
330	Bearing support	GS400
412.1	O-Ring (Axle Sleeve)	EPDM \ FPM \ FFKM
412.2	O-Ring (Casing)	EPDM \ FPM \ FPM enc. FEP
412.3	O-Ring (Stuffing box)	EPDM \ FPM \ FPM enc. FEP \ FFKM
451	Stuffing box	PP lined \ PVDF lined \ PFA lined
523	Axle Sleeve	PFA lined

# UCL-B

## Overall dimensions

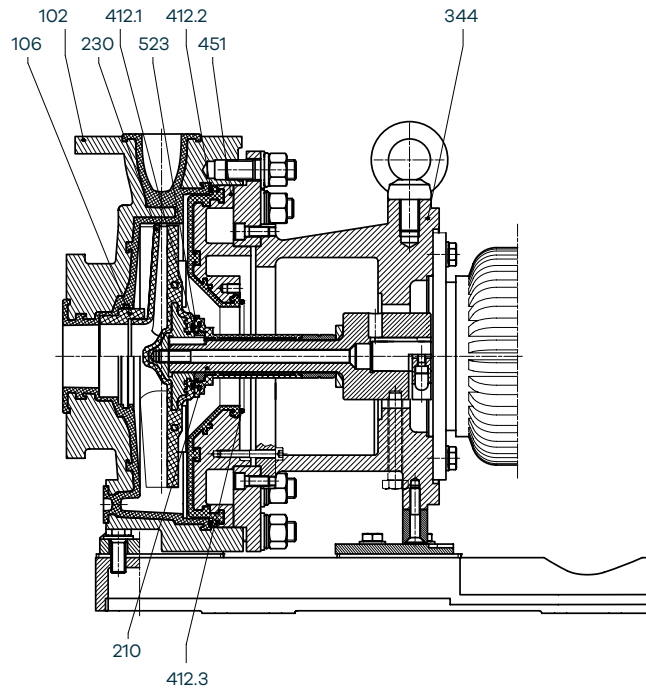

## Technical specifications

### Performance at 2900 rpm

Q max = 120 m<sup>3</sup>/h  
H max = 75 m

### Motors

UCL : 1,1 kW (motor size 80) > 55 kW  
(motor size 250)  
UCL-B : 1,1 kW (motor size 90) > 18.5 kW  
(motor size 160)

### Allowable temperatures

PP : -10 °C > +70 °C  
PVDF : -30 °C > +100 °C  
PFA : -50 °C > +140 °C

### Allowable pressures

PN16 (20 °C)

### Flange Connections

UNI 1092-2 / ISO 7005-2 PN 16, type B  
slotted ANSI 150

### Viscosity

min: 0,5 cSt  
max: 180 cSt

### Allowable solids

Max size: 1,5 mm

## Internal components

DIN	Components	Materials
102	Casing	PP lined \ PVDF lined \ PFA lined
106	Suction Casing	PFA
210	Axle	Aisi 431
230	Impeller	PP lined \ PVDF lined \ PFA lined
344	Bearing support	GS400
412.1	O-Ring (Axle Sleeve)	EPDM \ FPM \ FFKM
412.2	O-Ring (Casing)	EPDM \ FPM \ FPM enc. FEP
412.3	O-Ring (Stuffing box)	EPDM \ FPM \ FPM enc. FEP \ FFKM
451	Stuffing box	PP lined \ PVDF lined \ PFA lined
523	Axle Sleeve	PFA lined

# UCL

## Overall dimensions

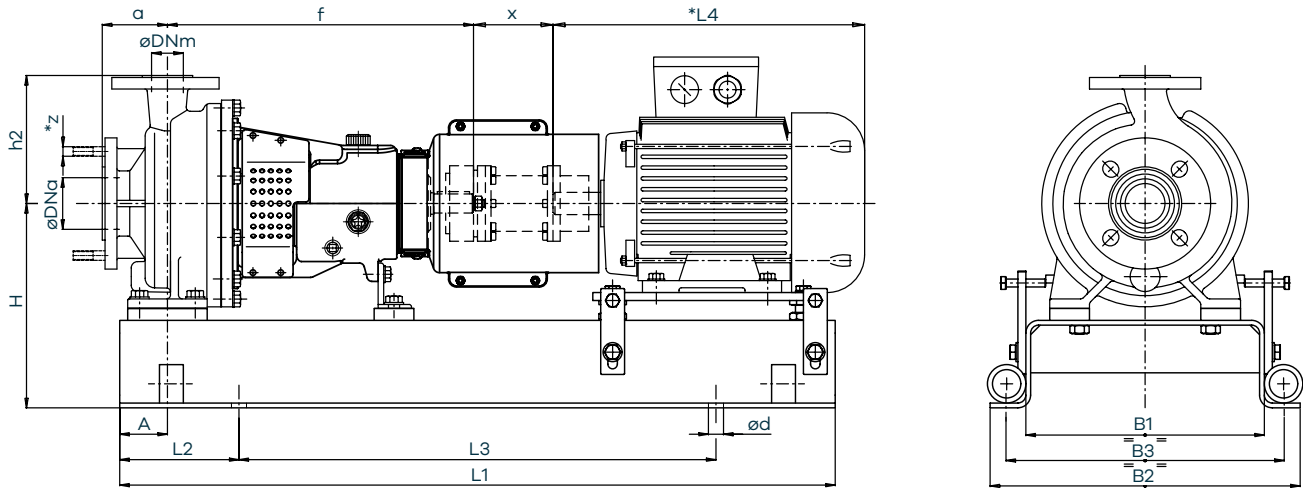

### Pump dimensions:

Model	25-25-125	40-25-160	50-32-160	65-40-160	80-50-125	80-50-160	50-32-200	65-40-200	80-50-200
<b>DNa ø</b>	25	40	50	65	80	80	50	65	80
	UNI EN 1092-1 PN 10RF slotted ANSI 150								
<b>DNm ø</b>	25	25	32	40	50	50	32	40	50
	UNI EN 1092-1 PN 10RF slotted ANSI 150								
<b>a (mm)</b>	80	80	80	80	100	100	80	100	100
<b>A (mm)</b>	60	60	60	60	60	60	60	60	60
<b>f (mm)</b>	385	385	385	385	385	385	385	385	385
<b>h2 (mm)</b>	160	160	160	160	160	180	180	180	200
<b>x (mm)</b>	100	100	100	100	100	100	100	100	100
<b>H - motor size</b>	<b>80 (mm)</b>	257	257	257	257	257	285	285	285
	<b>90 (mm)</b>	257	257	257	257	257	285	285	285
	<b>100 (mm)</b>	257	257	257	257	257	285	285	285
	<b>112 (mm)</b>	257	257	257	257	257	285	285	285
	<b>132 (mm)</b>	272	272	272	272	272	300	300	300
	<b>160 (mm)</b>	272	272	272	272	272	300	300	300
<b>180 (mm)</b>							300	300	300
<b>Pump weight (without motor)</b>	40	40	41	44	46	48	52	56	60

### Base dimensions:

Motor Size	B1 (mm)	B2 (mm)	B3 (mm)	ød (mm)	L1 (mm)	L2 (mm)	L3 (mm)	Base weight (without motor)
<b>80-90-100-112</b>	300	390	350	M16	900	150	600	45
<b>132</b>	340	450	400	M20	1000	170	660	58
<b>160-180</b>	380	490	440	M20	1120	190	740	90

\*L4 = the size depends on the manufacturer of the motor installed | \*z = DNm 80 equipped with 4 M16x60 studs for ANSI 150

# UCL

## Overall dimensions

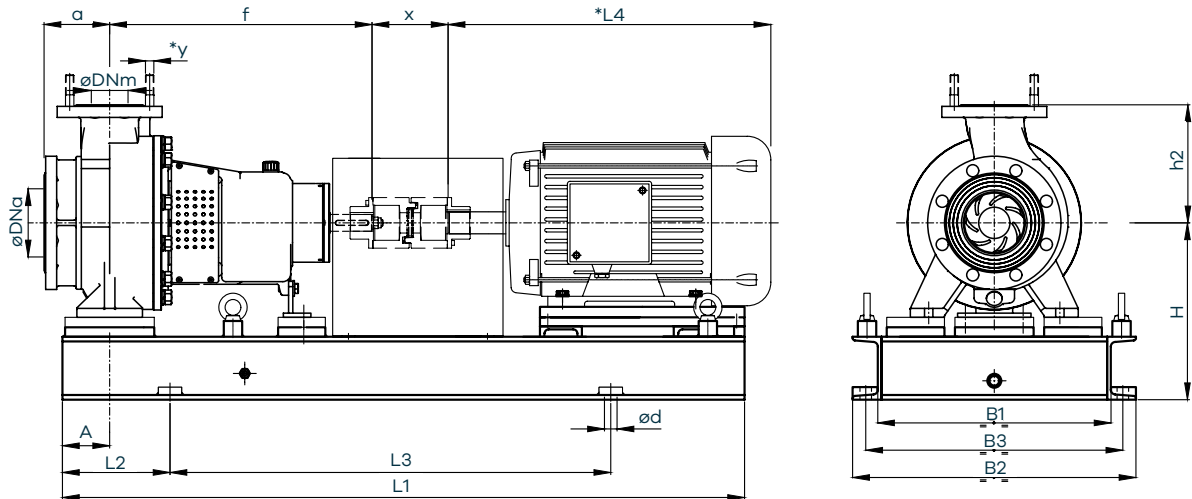

### Pump dimensions:

Model	125-80-160	125-80-200
DNa Ø	125	125
	UNI EN 1092-1 PN 16RF slotted ANSI 150	
DNm Ø	80	80
	UNI EN 1092-1 PN 16RF slotted ANSI 150	
a (mm)	125	125
A (mm)	75	75
f (mm)	500	500
h2 (mm)	225	250
x (mm)	140	140
H - motor size	132 (mm)	298
	160 (mm)	318
	180 (mm)	318
	200 (mm)	358
	225 (mm)	383
	250 (mm)	403
Pump weight (without motor)	100	115

### Base dimensions:

Motor Size	B1 (mm)	B2 (mm)	B3 (mm)	Ød (mm)	L1 (mm)	L2 (mm)	L3 (mm)	Base weight (without motor)
132	402	490	440	M20	1120	190	740	80
160-180	444	540	490	M20	1300	205	840	100
200-225	480	610	550	M24	1400	230	940	130
250	554	660	600	M24	1600	270	1060	170

\*L4 = the size depends on the manufacturer of the motor installed | \*z = DNm 80 equipped with 4 M16x60 studs for ANSI 150

# UCL

## Overall dimensions

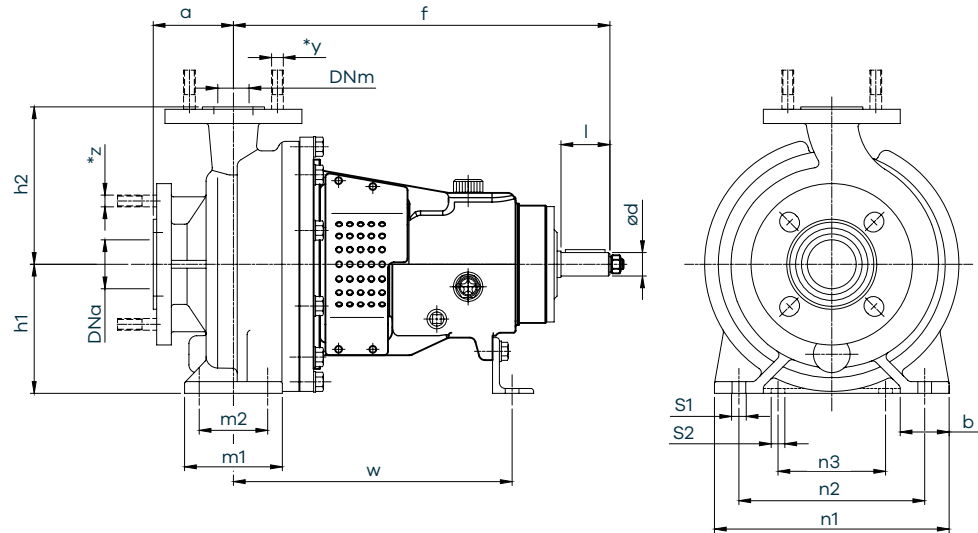

### Pump dimensions:

Model	25-25-160	40-25-160	50-32-160	65-40-160	80-50-125	80-50-160	50-32-200	65-40-200	80-50-200	125-80-160	125-80-200
<b>DNa Ø</b>	25	40	50	65	80	80	50	65	80	125	125
	UNI EN 1092-1 PN 10RF slotted ANSI 150										
<b>DNm Ø</b>	25	25	32	40	50	50	32	40	50	80	80
	UNI EN 1092-1 PN 10RF slotted ANSI 150										
<b>a (mm)</b>	80	80	80	80	100	100	80	100	100	125	125
<b>b (mm)</b>	50	50	50	50	50	50	50	50	50	65	65
<b>ød (mm)</b>	24	24	24	24	24	24	24	24	24	32	32
<b>f (mm)</b>	385	385	385	385	385	385	385	385	385	500	500
<b>h1 (mm)</b>	132	132	132	132	132	160	160	160	160	180	180
<b>h2 (mm)</b>	160	160	160	160	160	180	180	180	200	225	250
<b>l (mm)</b>	50	50	50	50	50	50	50	50	50	80	80
<b>m1 (mm)</b>	100	100	100	100	100	100	100	100	100	125	125
<b>m2 (mm)</b>	70	70	70	70	70	70	70	70	70	95	95
<b>n1 (mm)</b>	240	240	240	240	240	265	240	265	265	320	345
<b>n2 (mm)</b>	190	190	190	190	190	212	190	212	212	250	280
<b>n3 (mm)</b>	110	110	110	110	110	110	110	110	110	110	110
<b>S1 (mm)</b>	14	14	14	14	14	14	14	14	14	16	16
<b>S2 (mm)</b>	14	14	14	14	14	14	14	14	14	16	16
<b>w (mm)</b>	285	285	285	285	285	285	285	285	285	370	370
<b>Pump weight (without motor)</b>	40	40	41	44	46	48	53	56	60	100	115

\*y = DNm 80 equipped with 4 M16x60 studs for ANSI 10

# UCL-B

## Overall dimensions

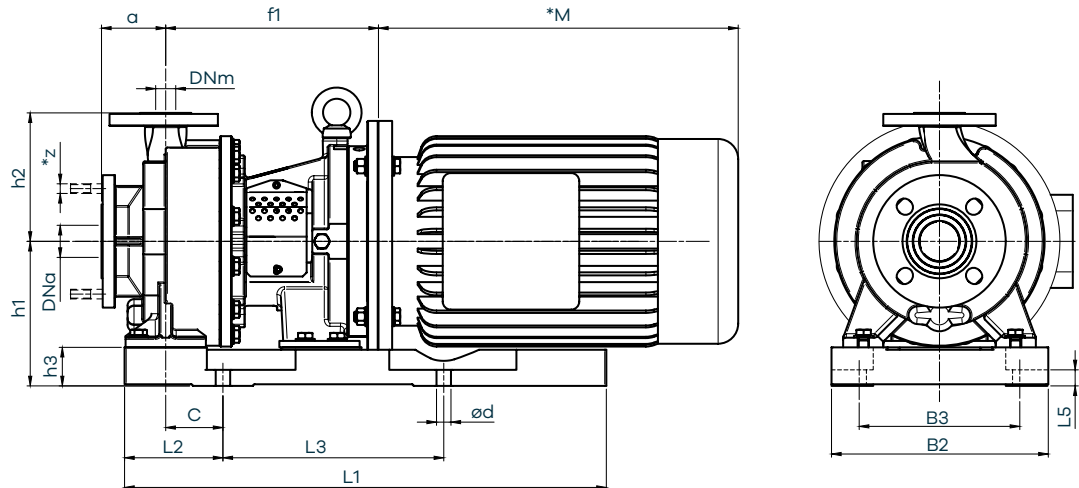

### Pump dimensions:

Model	25-25-160	40-25-160	50-32-160	65-40-160	80-50-125	80-50-160	50-32-200	65-40-200	80-50-200
<b>DNa Ø</b>	25	40	50	65	80	80	50	65	80
	UNI EN 1092-1 PN 16RF slotted ANSI 150								
<b>DNm Ø</b>	25	25	32	40	50	50	32	40	50
	UNI EN 1092-1 PN 16RF slotted ANSI 150								
<b>a (mm)</b>	80	80	80	80	100	100	80	100	100
<b>B2 (mm)</b>	270	270	270	270	270	270	270	270	270
<b>B3 (mm)</b>	200	200	200	200	200	200	200	200	200
<b>C (mm)</b>	70	70	70	70	70	70	70	70	70
<b>ød (mm)</b>	18	18	18	18	18	18	18	18	18
<b>h2 (mm)</b>	160	160	160	160	160	180	180	180	200
<b>h3 (mm)</b>	48	48	48	48	48	48	48	48	48
<b>L1 (mm)</b>	550	550	550	550	550	550	550	550	550
<b>L2 (mm)</b>	123	123	123	123	123	123	123	123	123
<b>L3 (mm)</b>	275	275	275	275	275	275	275	275	275
<b>L5 (mm)</b>	20	20	20	20	20	20	20	20	20
<b>90 (mm)</b>	226	226	226	226	226	226	226	226	226
<b>100 (mm)</b>	235	235	235	235	235	235	235	235	235
<b>112 (mm)</b>	235	235	235	235	235	235	235	235	235
<b>132 (mm)</b>	265	265	265	265	265	265	265	265	265
<b>160 (mm)</b>	280	280	280	280	280	280	280	280	280
<b>90 (mm)</b>	180	180	180	180	180	208	208	208	208
<b>100 (mm)</b>	180	180	180	180	180	208	208	208	208
<b>112 (mm)</b>	180	180	180	180	180	208	208	208	208
<b>132 (mm)</b>	180	180	180	180	180	208	208	208	208
<b>160 (mm)</b>	208	208	208	208	208	208	208	208	208
<b>Motor shape</b>	<b>B5</b>	<b>B5</b>	<b>B5</b>	<b>B5</b>	<b>B5</b>	<b>B5</b>	<b>B5</b>	<b>B5</b>	<b>B5</b>
<b>Pump weight (without motor)</b>	40	40	41	44	46	48	52	56	60

\*M dimension is according to installed motor manufacturer.



**CDR Pompe**

Via Raffaello Sanzio, 57  
20021 Bollate (MI)  
Tel. +39 02 9901941

[www.cdrpompe.com](http://www.cdrpompe.com)

**Technical characteristics:**

The data and technical characteristics shown in the General Catalogue are not binding. CDR Pompe SRL reserves the right to implement changes without notice. Therefore the data, the size, performance and any other information reported are indicative and not binding. For any technical details you can request the product update form.