



WE
PUMP
YOUR
CHEMICALS



MAGNETIC DRIVE
AND MECHANICAL SEAL
CENTRIFUGAL PUMPS

PRODUCTS
CATALOGUE

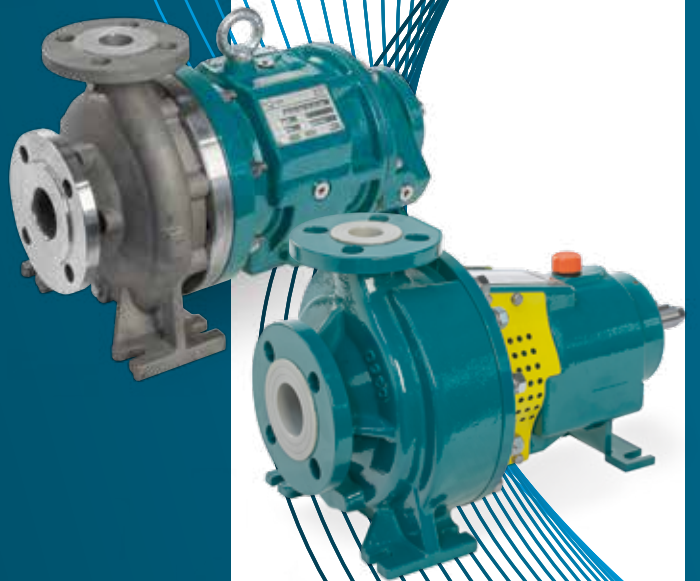

Index



LINED AND PLASTIC MAGNETIC DRIVE PUMPS

STN	6
ETN EVO	7
UTN-L	8
UTN-BL	9
DTN-L ASME	10
DTN-BL ASME	11
DTN-L ISO	12
DTN-BL ISO	13
XTN-BL	14
HTN	15



METALLIC MAGNETIC DRIVE PUMPS

UTS EVO	18
UTS-B EVO	19
ETS	20
XTS-B	21
HTS	22



OPTIONAL AVAILABLE

OPTIONAL	23
----------	----



LINED AND PLASTIC MECHANICAL SEAL PUMPS

UCL	26
UCL-B	27
CCL	28
CCN	29



CUSTOM-MADE PUMPS

UTS-B IN LINE	32
CVN	32
TMVN	33

Why choose CDR Pompe?

Full Support:

Our assistance is not limited to sales; it goes further, ensuring totally customer-oriented pre- and post-purchase support. We are here to guide you in choosing the most suitable product and to assist you at every stage of its life cycle. Immediate availability of spare parts and prompt delivery of pumps ensure that your processes continue to run smoothly, minimizing downtime and optimizing operational efficiency.

We are different:

Apart from technology, the true strength of CDR Pompe lies in its people. A team of dedicated professionals, with deep knowledge of the industry and a commitment to excellence, is what makes us different. Our company culture values customer service, innovation and quality, ensuring that every interaction with us is not only satisfying but also inspiring.

In touch with the future:

At CDR Pompe, we don't just follow the evolution of the sector; we drive it. With a future-oriented vision, we are committed to developing the solutions of tomorrow, today. Your trust in us fuels our passion for excellence, leading us to push the boundaries of what is possible. At CDR, you don't simply buy a pump; you invest in a lasting partnership, enriched by impeccable support, continuous innovation and an unwavering commitment to excellence. Because, in the end, your success is our success.



A leader in the chemical pump sector for over 50 years



In operation since the 1950s, we stand out in the Italian manufacturing panorama for the development and production of magnetic drive and mechanical seal centrifugal process pumps for dangerous, corrosive and toxic liquids.



Flexibility of production



Quick reaction times



Reliable and sustainable



Lined and Plastic Magnetic Drive Pumps

For temperatures and pressures outside the indicated limits,
for viscosity and solids outside the limits contact C.D.R. Pompe

STN

Plastic Magnetic Drive Centrifugal Pump

Application Fields:

- _ Basic Chemical Services
- _ Paper Industry
- _ Water Treatment (ion exchange resins)
- _ C.I.P.
- _ Galvanic Industry

Additional Arrangements:

- _ Type of casing: Drained
- _ Flange: UNI PN10RF or ANSI 150RF



ATEX 100
Directive: 2014/34/EU 

Standard Design:

Shaft seal type:	Magnetic Drive
Casing material:	ETFE-CFR - PP
Journal Bearing \ Shaft Material:	Graphite/SSIC/Ceramic PTFE-Carbon
Type of casing:	Radially split-Volute Casing
Impeller material:	ETFE - PP
Type of impeller:	Closed
Nozzle position:	End suction
Type of Execution:	Horizontal - Close-Coupled
Pull-out design:	Yes
Heatable:	NA
Type of connection:	GAS - Flange
Flange:	Optional
Suction characteristics:	Non-priming
Type of lubrication:	NA
Maximum rated pressure @20°C:	PN 6
Max. permissible fluid temperature:	PP: 0°C > +60°C ETFE: -15°C > +80°C
Maximum head @ 2900 RPM:	30 m
Maximum flow rate @ 2900 RPM:	50 m³/h
Allowable Medium Viscosity Range:	0,5 cSt - 150 cSt
Maximum drive rating:	7,5 kW

ETN EVO

Lined Magnetic Drive Centrifugal Pump

Application Fields:

- _ Basic Chemical Services
- _ Basic Chemical Processing
- _ Batch Fine Chemical services
- _ Air Treatment - Scrubber
- _ Detergents Industry
- _ Paper Industry
- _ Water Treatment (ion exchange resins)
- _ C.I.P.

Additional Arrangements:

- _ Bushings: Diamond SSIC
- _ Type of casing: Drained



ATEX 100
Directive: 2014/34/EU 

Standard Design:

Shaft seal type:	Magnetic Drive
Design:	EN 22858; ISO 2858
Casing material:	ETFE Lined - PP Lined
Journal Bearing \ Shaft Material:	Graphite/SSIC/Ceramic PTFE-Carbon
Type of casing:	Radially split-Volute Casing
Impeller material:	ETFE Lined - PP Lined
Type of impeller:	Closed
Nozzle position:	End suction
Type of Execution:	Horizontal - Close-Coupled
Pull-out design:	Yes
Heatable:	NA
Type of connection:	Flange
Flange:	UNI 1092-2 (ISO 7005-2) PN16RF slotted to ANSI 150
Suction characteristics:	Non-priming
Type of lubrication:	NA
Maximum rated pressure @20°C:	PN 10
Max. permissible fluid temperature:	PP: -10°C > +65°C ETFE: -15°C > +120°C
Maximum head @ 2900 RPM:	35 m
Maximum flow rate @ 2900 RPM:	60 m³/h
Allowable Medium Viscosity Range:	0,5 cSt - 150 cSt
Maximum drive rating:	7,5 kW

UTN-L

Lined Magnetic Drive Process Centrifugal Pump

Application Fields:

- _ Active Pharmaceutical Ingredients Industries
- _ Fine Chemical Processing
- _ Basic Chemical Processing
- _ Petrochemical Services

Additional Arrangements:

- _ Bushings: Diamond SSIC
- _ Type of casing: Drained
- _ Max. permissible fluid temperature: PFA: - 50°C > +160°C
Conductive PFA execution on request



ATEX 100
Directive: 2014/34/EU 

UTN-BL

Lined Magnetic Drive Process Centrifugal Pump

Application Fields:

- _ Active Pharmaceutical Ingredients Industries
- _ Basic Chemical Processing
- _ Fine Chemical Processing
- _ Air Treatment - Scrubber
- _ Detergents Industry
- _ Petrochemical Services

Additional Arrangements:

- _ Bushings: Diamond SSIC
- _ Type of casing: Drained
- _ Max. permissible fluid temperature: PFA: - 50°C > +160°C
Conductive PFA execution on request



ATEX 100
Directive: 2014/34/EU 

Standard Design:

Shaft seal type:	Magnetic Drive
Design:	EN 22858; ISO 2858; ISO15783
Casing material:	PFA Lined - PVDF Lined - PP Lined
Journal Bearing \ Shaft Material:	Graphite/SSIC/Ceramic PTFE-Carbon
Type of casing:	Radially split-Volute Casing
Impeller material:	PFA Lined - PVDF Lined PP Lined
Type of impeller:	Closed
Nozzle position:	End suction
Type of Execution:	Horizontal - Long-coupled
Pull-out design:	Yes
Heatable:	NA
Type of connection:	Flange
Flange:	UNI 1092-2 (ISO 7005-2) PN16RF slotted to ANSI 150
Suction characteristics:	Non-priming
Type of lubrication:	Grease
Maximum rated pressure @20°C:	PN 16
Max. permissible fluid temperature:	PP: -10°C > +70°C PVDF: -30°C > +100°C PFA: -50°C > +160°C
Maximum head @ 2900 RPM:	60 m
Maximum flow rate @ 2900 RPM:	150 m³/h
Allowable Medium Viscosity Range:	0,5 cSt - 150 cSt
Maximum drive rating:	37 kW

Standard Design:

Shaft seal type:	Magnetic Drive
Design:	EN 22858; ISO 2858; ISO15783
Casing material:	PFA Lined - PVDF Lined - PP Lined
Journal Bearing \ Shaft Material:	Graphite/SSIC/Ceramic PTFE-Carbon
Type of casing:	Radially split-Volute Casing
Impeller material:	PFA Lined - PVDF Lined PP Lined
Type of impeller:	Closed
Nozzle position:	End suction
Type of Execution:	Horizontal - Close-Coupled
Pull-out design:	Yes
Heatable:	NA
Type of connection:	Flange
Flange:	UNI 1092-2 (ISO 7005-2) PN16RF slotted to ANSI 150
Suction characteristics:	Non-priming
Type of lubrication:	NA
Maximum rated pressure @20°C:	PN 16
Max. permissible fluid temperature:	PP: -10°C > +70°C PVDF: -30°C > +100°C PFA: -50°C > +160°C
Maximum head @ 2900 RPM:	60 m
Maximum flow rate @ 2900 RPM:	150 m³/h
Allowable Medium Viscosity Range:	0,5 cSt - 150 cSt
Maximum drive rating:	18,5 kW (37Kw only on bracket II)

DTN-L ASME

Lined Magnetic Drive Process Centrifugal Pump

Application Fields:

- _ Active Pharmaceutical Ingredients Industries
- _ Fine Chemical Processing
- _ Basic Chemical Processing
- _ Petrochemical Processing

Additional Arrangements:

- _ Bushings: Diamond SSIC
- _ Type of casing: Drained



ATEX 100
Directive: 2014/34/EU 

DTN-BL ASME

Lined Magnetic Drive Process Centrifugal Pump

Application Fields:

- _ Active Pharmaceutical Ingredients Industries
- _ Basic Chemical Processing
- _ Fine Chemical Processing
- _ Air Treatment - Scrubber
- _ Petrochemical Services

Additional Arrangements:

- _ Bushings: Diamond SSIC
- _ Type of casing: Drained



ATEX 100
Directive: 2014/34/EU 

Standard Design:

Shaft seal type:	Magnetic Drive
Design:	ASME B73.3-2015
Standard:	ASME B73.3-2015
Casing material:	ETFE Lined
Journal Bearing \ Shaft Material:	SSIC
Type of casing:	Radially split-Volute Casing
Impeller material:	ETFE Lined
Type of impeller:	Closed
Nozzle position:	End suction
Type of Execution:	Horizontal - Long-Coupled
Pull-out design:	Back pull-out
Heatable:	NA
Type of connection:	Flange
Flange:	ASME B16.5 Class 150
Suction characteristics:	Non-priming
Type of lubrication:	Oil lubrication
Maximum rated pressure @20°C:	PN 16
Max. permissible fluid temperature:	-30°C > +120°C
Maximum head @ 3500 RPM:	105 m
Maximum flow rate @ 3500 RPM:	108 m³/h
Allowable Medium Viscosity Range:	0,5 cSt - 150 cSt
Maximum drive rating:	22 kW

Standard Design:

Shaft seal type:	Magnetic Drive
Design:	ASME B73.3-2015
Standard:	ASME B73.3-2015
Casing material:	ETFE Lined
Journal Bearing \ Shaft Material:	SSIC
Type of casing:	Radially split-Volute Casing
Impeller material:	ETFE Lined
Type of impeller:	Closed
Nozzle position:	End suction
Type of Execution:	Horizontal - Close-Coupled
Pull-out design:	Back pull-out
Heatable:	NA
Type of connection:	Flange
Flange:	ASME B16.5 Class 150
Suction characteristics:	Non-priming
Type of lubrication:	No
Maximum rated pressure @20°C:	PN 16
Max. permissible fluid temperature:	-30°C > +120°C
Maximum head @ 3500 RPM:	105 m
Maximum flow rate @ 3500 RPM:	108 m³/h
Allowable Medium Viscosity Range:	0,5 cSt - 150 cSt
Maximum drive rating:	22 kW

DTN-L ISO

Lined Magnetic Drive Process Centrifugal Pump

Application Fields:

- _ Active Pharmaceutical Ingredients Industries
- _ Fine Chemical Processing
- _ Basic Chemical Processing
- _ Petrochemical Processing

Additional Arrangements:

- _ Bushings: Diamond SSIC
- _ Type of casing: Drained



ATEX 100
Directive: 2014/34/EU 

DTN-BL ISO

Lined Magnetic Drive Process Centrifugal Pump

Application Fields:

- _ Active Pharmaceutical Ingredients Industries
- _ Basic Chemical Processing
- _ Fine Chemical Processing
- _ Air Treatment - Scrubber
- _ Petrochemical Services

Additional Arrangements:

- _ Bushings: Diamond SSIC
- _ Type of casing: Drained



ATEX 100
Directive: 2014/34/EU 

Standard Design:

Shaft seal type:	Magnetic Drive
Design:	EN 2258; ISO 2858; ISO 15783
Casing material:	ETFE Lined
Journal Bearing \ Shaft Material:	SSIC
Type of casing:	Radially split-Volute Casing
Impeller material:	ETFE Lined
Type of impeller:	Closed
Nozzle position:	End suction
Type of Execution:	Horizontal - Long-Coupled
Pull-out design:	Back pull-out
Heatable:	NA
Type of connection:	Flange
Flange:	UNI 1092-2 / ISO 7005-2 PN16 type B slotted ANSI150RF
Suction characteristics:	Non-priming
Type of lubrication:	Grease lubrication
Maximum rated pressure @20°C:	PN 16
Max. permissible fluid temperature:	-20°C > +120°C
Maximum head @ 2900 RPM:	115 m
Maximum flow rate @ 2900 RPM:	115 m³/h
Allowable Medium Viscosity Range:	0,5 cSt - 150 cSt
Maximum drive rating:	22 kW

Standard Design:

Shaft seal type:	Magnetic Drive
Design:	EN 2258; ISO 2858; ISO 15783
Casing material:	ETFE Lined
Journal Bearing \ Shaft Material:	SSIC
Type of casing:	Radially split-Volute Casing
Impeller material:	ETFE Lined
Type of impeller:	Closed
Nozzle position:	End suction
Type of Execution:	Horizontal - Close-Coupled
Pull-out design:	Back pull-out
Heatable:	NA
Type of connection:	Flange
Flange:	UNI 1092-2 / ISO 7005-2 PN16 type B slotted ANSI150RF
Suction characteristics:	Non-priming
Type of lubrication:	No
Maximum rated pressure @20°C:	PN 16
Max. permissible fluid temperature:	-20°C > +120°C
Maximum head @ 2900 RPM:	115 m
Maximum flow rate @ 2900 RPM:	115 m³/h
Allowable Medium Viscosity Range:	0,5 cSt - 150 cSt
Maximum drive rating:	18,5 kW

XTN-BL

Lined Magnetic Drive Process Centrifugal Pump with Open Impeller

Application Fields:

- _ Active Pharmaceutical Ingredients Industries
- _ Basic Chemical Processing
- _ Fine Chemical Processing
- _ Air Treatment - Scrubber
- _ For fluids with solid particles
- _ Petrochemical Services

Additional Arrangements:

- _ Type of casing: Drained
- _ Horizontal - Long-Coupled



ATEX 100
Directive: 2014/34/EU 

Standard Design:

Shaft seal type:	Magnetic Drive
Design:	EN 22858; ISO 2858; ISO 15783
Casing material:	PFA Lined
Journal Bearing \ Shaft Material:	Diamond SSIC
Type of casing:	Radially split-Volute Casing
Impeller material:	PFA Lined
Type of impeller:	Open
Nozzle position:	End suction
Pull-out design:	Yes
Heatable:	NA
Type of connection:	Flange
Flange:	UNI 1092-2 (ISO 7005-2) PN16RF slotted to ANSI 150
Suction characteristics:	Non-priming
Type of lubrication:	NA
Maximum rated pressure @20°C:	PN 16
Max. permissible fluid temperature:	PFA: -50°C > +160°C
Maximum head @ 2900 RPM:	60 m
Maximum flow rate @ 2900 RPM:	70 m³/h
Allowable Medium Viscosity Range:	0,5 cSt - 180 cSt
Maximum drive rating:	18,5 kW

HTN

Plastic Magnetic Drive Peripheral Pump

Application Fields:

- _ Active Pharmaceutical Ingredients Industries
- _ Pharmaceutical Industries
- _ Petrochemical Services
- _ General Industry
- _ Low Flow Applications

Additional Arrangements:

- _ Type of casing: Drained



ATEX 100
Directive: 2014/34/EU 

Standard Design:

Shaft seal type:	Magnetic Drive
Design:	Standard Manufacturer
Casing material:	PP - PVDF
Journal Bearing \ Shaft Material:	SSIC / Graphite / Ceramic / PTFE-Carbon
Type of casing:	Positive displacement
Impeller material:	PVDF
Type of impeller:	Side Channel Impeller
Nozzle position:	Side suction
Type of Execution:	Horizontal - Close-Coupled
Pull-out design:	Yes
Heatable:	NA
Type of connection:	Yes
Flange:	UNIPN16RF ANSI150RF
Suction characteristics:	NA
Type of lubrication:	NA
Maximum rated pressure @20°C:	10 bar
Max. permissible fluid temperature:	-10°C > +80°C
Maximum head @ 2900 RPM:	75 m
Maximum flow rate @ 2900 RPM:	5 m³/h
Allowable Medium Viscosity Range:	0,5 cSt - 150 cSt
Maximum drive rating:	7,5 kW

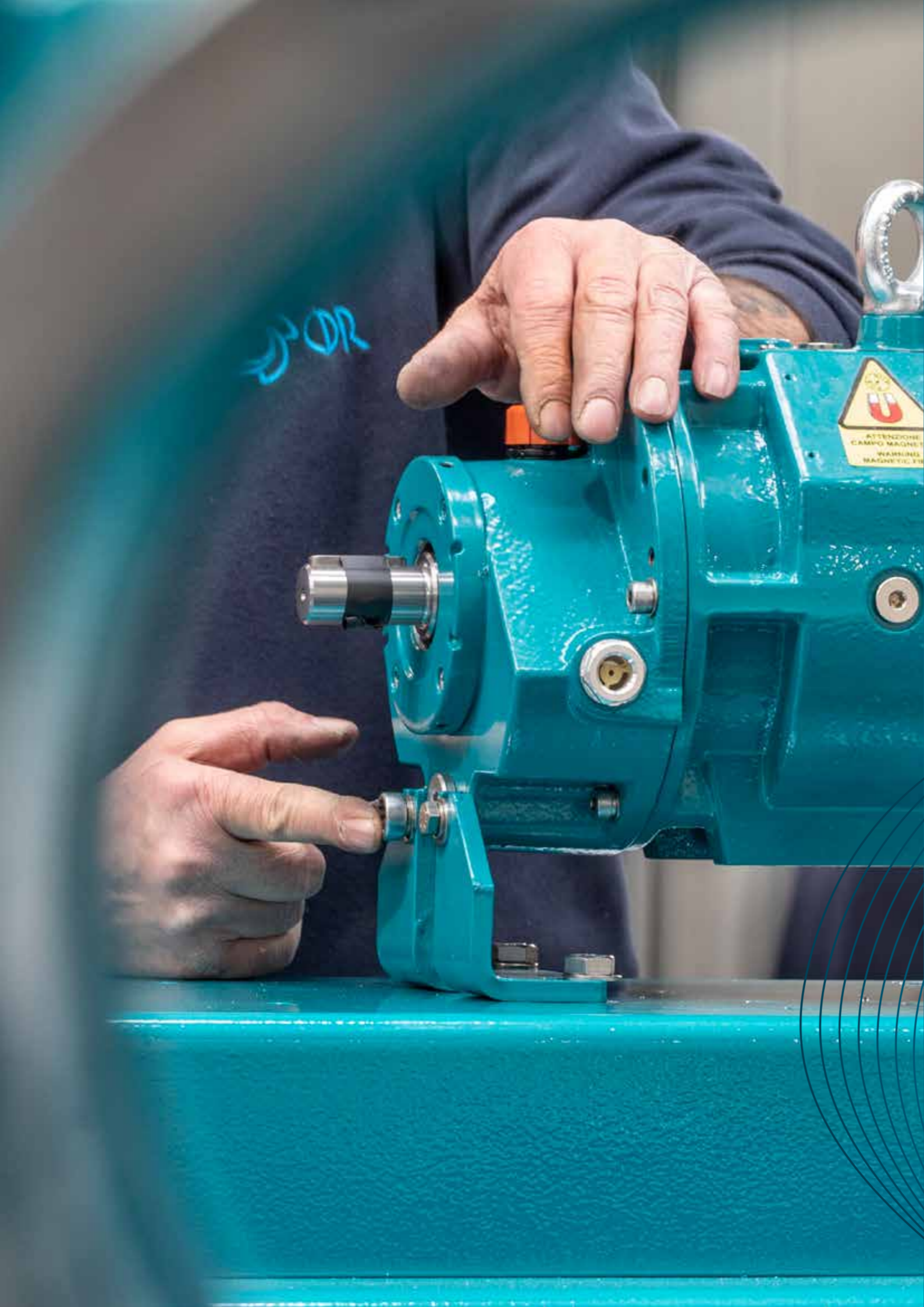

Metallic Magnetic Drive Pumps

For temperatures and pressures outside the indicated limits,
for viscosity and solids outside the limits contact C.D.R. Pompe

UTS EVO

Metallic Magnetic Drive Process Centrifugal Pump

Application Fields:

- _ Active Pharmaceutical Ingredients Industries
- _ Distillation Processing
- _ Basic Chemical Processing h24
- _ Fine Chemical Processing
- _ Thermoregulation Circuits
- _ Tankers Loading/Unloading
- _ Pharmaceutical-Chemical Industries

Additional Arrangements:

- _ Bushings: Diamond SSIC
- _ Isolation shell: Zirconium Oxide
- _ Heatable: Jacketed Hydraulic Casing | Jacketed Bushing Support
- _ Flange: slotted to ANSI 150
- _ Max. permissible fluid temperature: -140°C >+300 °C
- _ Lantern: Flushed
- _ Bearing bracket: Non Contacting Labyrinth Seal



ATEX 100
Directive: 2014/34/EU 

UTS-B EVO

Metallic Magnetic Drive Process Centrifugal Pump

Application Fields:

- _ Active Pharmaceutical Ingredients Industries
- _ Distillation Processing
- _ Basic Chemical Processing
- _ Fine Chemical Processing
- _ Thermoregulation Circuits
- _ Petrochemical Processing
- _ Fibre Processing
- _ Agro-pharma Processing

Additional Arrangements:

- _ Bushings: Diamond SSIC
- _ Isolation shell: Zirconium Oxide
- _ Heatable: Jacketed Hydraulic Casing | Jacketed Bushing Support
- _ Flange: slotted to ANSI 150
- _ Max. permissible fluid temperature: -100°C > +250 °C
- _ Lantern: Flushed



ATEX 100
Directive: 2014/34/EU 

Standard Design:

Shaft seal type:	Magnetic Drive
Design:	EN 22858; ISO 2858; ISO 15783
Casing material:	1.4408
Journal Bearing \ Shaft Material:	Graphite/SSIC
Type of casing:	Radially split-Volute Casing
Impeller material:	1.4408
Type of impeller:	Closed
Nozzle position:	End suction
Type of Execution:	Horizontal - Long-Coupled
Pull-out design:	Yes
Heatable:	Yes, optional
Type of connection:	Flange
Flange:	UNI 1092-1 (ISO 7005-1) PN16RF
Suction characteristics:	Non-priming
Type of lubrication:	Oil lubrication
Maximum rated pressure @20°C:	PN 16
Max. permissible fluid temperature:	-140°C > +300°C
Maximum head @ 2900 RPM:	100 m
Maximum flow rate @ 2900 RPM:	300 m³/h
Allowable Medium Viscosity Range:	0,5 cSt - 180 cSt
Maximum drive rating:	90 kW

Standard Design:

Shaft seal type:	Magnetic Drive
Design:	EN 22858; ISO 2858; ISO 15783
Casing material:	1.4408
Journal Bearing \ Shaft Material:	Graphite/SSIC
Type of casing:	Radially split-Volute Casing
Impeller material:	1.4408
Type of impeller:	Closed
Nozzle position:	End suction
Type of Execution:	Horizontal - Close-Coupled
Pull-out design:	Yes
Heatable:	Yes, optional
Type of connection:	Flange
Flange:	UNI 1092-1 (ISO 7005-1) PN16RF
Suction characteristics:	Non-priming
Type of lubrication:	NA
Maximum rated pressure @20°C:	PN 16
Max. permissible fluid temperature:	-100°C > +250°C
Maximum head @ 2900 RPM:	100 m
Maximum flow rate @ 2900 RPM:	150 m³/h
Allowable Medium Viscosity Range:	0,5 cSt - 180 cSt
Maximum drive rating:	45 kW

ETS Metallic Magnetic Drive Centrifugal Pump

Application Fields:

- _ Basic Chemical Services
- _ Batch fine chemical Processing
- _ Detergents Industry
- _ Thermoregulation Circuits
- _ Petrochemical Services

Additional Arrangements:

- _ Heatable: Available on 50-70 Series:
Jacketed Hydraulic Casing | Jacketed Bushing Support
- _ Max. permissible fluid temperature: -40°C > +180°C



ATEX 100
Directive: 2014/34/EU 

Standard Design:

Shaft seal type:	Magnetic Drive
Design:	EN 22858; ISO 2858
Casing material:	1.4408
Journal Bearing \ Shaft Material:	Graphite/SSIC
Type of casing:	Radially split-Volute Casing
Impeller material:	1.4408
Type of impeller:	Closed
Nozzle position:	End suction
Type of Execution:	Horizontal - Close-Coupled
Pull-out design:	Yes
Heatable:	NA
Type of connection:	Flange
Flange:	UNI 1092-1 (ISO 7005-1) PN16RF Drilling slotted to ANSI 150
Suction characteristics:	Non-priming
Type of lubrication:	NA
Maximum rated pressure @20°C:	PN 10
Max. permissible fluid temperature:	-40°C > +180°C
Maximum head @ 2900 RPM:	42 m
Maximum flow rate @ 2900 RPM:	45 m³/h
Allowable Medium Viscosity Range:	0,5 cSt - 180 cSt
Maximum drive rating:	7,5 kW

XTS-B Metallic Magnetic Drive Process Centrifugal Pump with Open Impeller

Application Fields:

- _ Active Pharmaceutical Ingredients Industries
- _ Basic Chemical Processing
- _ Fine Chemical Processing
- _ Fibre Processing
- _ Petrochemical Processing
- _ Agro-pharma Processing
- _ For fluids with solids particles

Additional Arrangements:

- _ Flange: slotted ANSI 150
- _ Max. permissible fluid temperature: -40°C > +180°C
Horizontal - Long-Coupled



ATEX 100
Directive: 2014/34/EU 

Standard Design:

Shaft seal type:	Magnetic Drive
Design:	EN 22858; ISO 2858
Standard:	EN 15783
Casing material:	1.4408
Journal Bearing \ Shaft Material:	Diamond SSIC
Type of casing:	Radially split-Volute Casing
Impeller material:	1.4408
Type of impeller:	Open
Nozzle position:	End suction
Type of Execution:	Horizontal - Close-Coupled
Pull-out design:	Yes
Type of connection:	Flange
Flange:	UNI 1092-1 (ISO 7005-1) PN16RF
Suction characteristics:	Non-priming
Type of lubrication:	NA
Maximum rated pressure @20°C:	PN 16
Max. permissible fluid temperature:	-40°C > +180°C
Maximum head @ 2900 RPM:	65 m
Maximum flow rate @ 2900 RPM:	70 m³/h
Allowable Medium Viscosity Range:	0,5 cSt - 180 cSt
Maximum drive rating:	18,5 kW

HTS

Metallic Magnetic Drive Peripheral Pump

Application Fields:

- _ Active Pharmaceutical Ingredients Industries
- _ Pharmaceutical Industries
- _ Petrochemical Services
- _ General Industry
- _ Low Flow Applications

Additional Arrangements:

- _ Type of casing: Drained



ATEX 100
Directive: 2014/34/EU

OPTIONS AVAILABLE

Dry run protection: RUN SAFE SSIC (Diamond coated SSIC)

RunSafe SSIC: the solution to protect magnetic driven pumps from dry run. CDR developed a solution to prevent pump failures in case priming failure or wrong start up, giving chance to stop the pump before rising of catastrophic damages. Tank unloading simulation test on UTS EVO 80-50-200: Bushes failure happened after 60' from pump unpriming with diamond coated bushes!

Available CDR pumps with Run Safe SSIC: ETN, UTN, UTS, XTN, XTS and DTN



Standard Design:

Shaft seal type:	Magnetic Drive
Design:	Standard Manufacturer
Standard:	Standard Manufacturer
Casing material:	1.4408
Journal Bearing \ Shaft Material:	SSIC / Graphite / Peek / PTFE-Carbon
Type of casing:	Positive displacement
Impeller material:	1.4408
Type of impeller:	Side Channel Impeller
Nozzle position:	Side suction
Type of Execution:	Horizontal - Close-Coupled
Pull-out design:	Yes
Heatable:	NA
Type of connection:	GAS - Flange
Flange:	UNIPN16RF ANSI150RF
Suction characteristics:	NA
Type of lubrication:	NA
Maximum rated pressure @20°C:	20 bar
Max. permissible fluid temperature:	-30°C > +180°C
Maximum head @ 2900 RPM:	170 m
Maximum flow rate @ 2900 RPM:	5 m³/h
Allowable Medium Viscosity Range:	0,5 cSt - 180 cSt
Maximum drive rating:	7,5 kW

Energy Efficiency

Thanks to zirconium oxyde isolation shell, instead of traditional Hastelloy-C isolation shell, Eddy-current losses are eliminated and magnetic driven pump efficiency increases significantly.

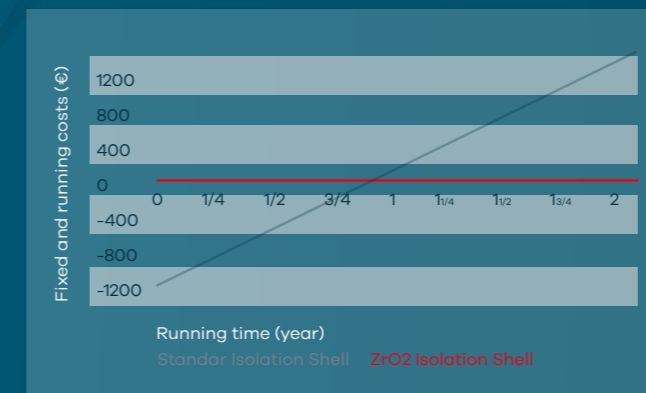
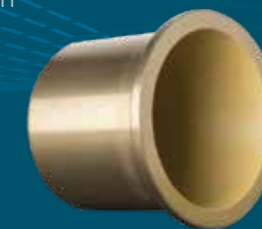

RUN SAFE SSIC + Zirconium Oxyde Isolation Shell

The same tank unloading test has been done on UTS EVO 80-50-200 with zirconium oxyde isolation shell and diamond coated bushes.

The test showed a surprising result, the pump run "dry" for 534 minutes after pump unpriming before failure! With zirconium oxyde isolation shell, temperature inside the pump is significantly lower, therefore the remaining fluid inside the pump do not completely vaporize, permitting bushes lubrication and long running time in critical conditions.



Lined and Plastic Mechanical Seal Pumps

For temperatures and pressures outside the indicated limits,
for viscosity and solids outside the limits contact C.D.R. Pompe

UCL

Lined Mechanical Seal Centrifugal Pump

Application Fields:

- _ Active Pharmaceutical Ingredients Industries
- _ Basic Chemical Processing
- _ Fine Chemical Processing (recirculation of catalyst solution)
- _ Air Treatment - Scrubber
- _ Petrochemical Services
- _ Waste Water Treatment

Additional Arrangements:

- _ Type of casing: Drained
- _ Mechanical Seal:
CDR Mechanical Seal: CSS Single Mechanical Seal | CDC Double Cartridge
All standard-compliant makes EN ISO 12756 (ex DIN 24960):
Single/Double Mechanical Seals | Single/Double Cartridge Mechanical Seals



ATEX 100
Directive: 2014/34/EU 

UCL-B

Lined Mechanical Seal Centrifugal Pump

Application Fields:

- _ Basic Chemical Processing
- _ Air Treatment - Scrubber
- _ Petrochemical Services
- _ Waste Water Treatment

Additional Arrangements:

- _ Type of casing: Drained
- _ Mechanical Seal:
CDR Mechanical Seal: CSS Single Mechanical Seal | CDC Double Cartridge
All standard-compliant makes EN ISO 12756 (ex DIN 24960):
Single/Double Mechanical Seals | Single/Double Cartridge Mechanical Seals



ATEX 100
Directive: 2014/34/EU 

Standard Design:

Shaft seal type:	Mechanical seal
Design:	EN 22858; ISO 2858; ISO 5199
Casing material:	PFA Lined - PVDF Lined - PP Lined
Type of casing:	Radially split-Volute Casing
Impeller material:	PFA Lined - PVDF Lined - PP Lined
Type of impeller:	Closed; Radial
Nozzle position:	End suction
Type of Execution:	Horizontal - Long-Coupled
Pull-out design:	Yes
Heatable:	NA
Type of connection:	Flange
Flange:	UNI 1092-2 (ISO 7005-2) PN16RF slotted to ANSI 150
Suction characteristics:	Non-priming
Type of lubrication:	Oil lubrication
Maximum rated pressure @20°C:	PN 16 PP: -10°C > +70°C PVDF: -30°C > +100°C PFA: -50°C > +140°C
Max. permissible fluid temperature:	PVDF: -30°C > +100°C PFA: -50°C > +140°C
Maximum head @ 2900 RPM:	75 m
Maximum flow rate @ 2900 RPM:	250 m³/h
Allowable Medium Viscosity Range:	0,5 cSt - 180 cSt
Maximum drive rating:	55 kW

Standard Design:

Shaft seal type:	Mechanical seal
Design:	EN 22858; ISO 2858; ISO 5199
Casing material:	PFA Lined - PVDF Lined - PP Lined
Type of casing:	Radially split-Volute Casing
Impeller material:	PFA Lined - PVDF Lined - PP Lined
Type of impeller:	Closed; Radial
Nozzle position:	End suction
Type of Execution:	Horizontal - Close-Coupled
Pull-out design:	Yes
Heatable:	NA
Type of connection:	Flange
Flange:	UNI 1092-2 (ISO 7005-2) PN16RF slotted to ANSI 150
Suction characteristics:	Non-priming
Type of lubrication:	NA
Maximum rated pressure @20°C:	PN 16 PP: -10°C > +70°C PVDF: -30°C > +100°C PFA: -50°C > +140°C
Max. permissible fluid temperature:	PVDF: -30°C > +100°C PFA: -50°C > +140°C
Maximum head @ 2900 RPM:	75 m
Maximum flow rate @ 2900 RPM:	120 m³/h
Allowable Medium Viscosity Range:	0,5 cSt - 180 cSt
Maximum drive rating:	18,5 kW

CCL

Lined Mechanical Seal Centrifugal Pump

Application Fields:

- _ Basic Chemical Processing
- _ Air Treatment - Scrubber
- _ Petrochemical Services
- _ Waste Water Treatment

Additional Arrangements:

Mechanical Seal:

- _ CDR Mechanical Seal: CSE Single Mechanical Seal
- _ Mechanical Seal: TSI Single Internal | TSE Single External | Double Tandem Mechanical Seals
- _ CCL-B Close-Coupled Version



ATEX 100
Directive: 2014/34/EU 

Standard Design:

Shaft seal type:	Mechanical seal
Design:	EN 22858; ISO 2858; ISO 5199
Casing material:	PP Lined
Type of casing:	Radially split-Volute Casing
Impeller material:	PP Lined
Type of impeller:	Closed; Radial
Nozzle position:	End suction
Pull-out design:	Yes
Heatable:	NA
Type of connection:	Flange
Flange:	UNI 1092-2 (ISO 7005-2) PN16RF slotted to ANSI 150
Suction characteristics:	Non-priming
Type of lubrication:	Oil lubrication
Maximum rated pressure @20°C:	PN 16
Max. permissible fluid temperature:	PP: -10°C > +70°C
Maximum head @ 2900 RPM:	75 m
Maximum flow rate @ 2900 RPM:	250 m³/h
Allowable Medium Viscosity Range:	0,5 cSt - 180 cSt
Maximum drive rating:	55 kW

CCN

Mechanical Seal Centrifugal Pump

Application Fields:

- _ Active Pharmaceutical Ingredients Industries
- _ Basic Chemical Processing
- _ Fine Chemical Processing (recirculation of catalyst solution)
- _ Air Treatment - Scrubber
- _ Petrochemical Services
- _ Waste Water Treatment

Additional Arrangements:

- _ Type of casing: Drained
- _ Max. permissible fluid temperature: On Request
- _ Mechanical Seal:
CDR Mechanical Seal: FC50 Single Mechanical Seal
All standard-compliant makes EN ISO 12756 (ex DIN 24960)



ATEX 100
Directive: 2014/34/EU 

Standard Design:

Shaft seal type:	Mechanical seal
Design:	EN 22858; ISO 2858; ISO 5199
Casing material:	PP - PVDF - PEHD
Type of casing:	Radially split-Volute Casing
Impeller material:	PVDF - PEHD
Type of impeller:	Closed
Nozzle position:	End suction
Type of Execution:	Horizontal - Long-Coupled
Pull-out design:	Yes
Heatable:	NA
Type of connection:	Flange
Flange:	UNI 1092-2 (ISO 7005-2) PN16RF slotted to ANSI 150
Suction characteristics:	Non-priming
Type of lubrication:	Oil lubrication
Maximum rated pressure @20°C:	PN 16
Max. permissible fluid temperature:	PP: 0°C > +70°C PVDF: -15°C > +90°C
Maximum head @ 2900 RPM:	100 m
Maximum flow rate @ 2900 RPM:	300 m³/h
Allowable Medium Viscosity Range:	0,5 cSt - 180 cSt
Maximum drive rating:	55 kW

CSS Single Mechanical Seal

Characteristics:

Suitable to work with low/moderate dirty corrosive liquids. Easy maintenance thanks to the semi-cartridge design. Extremely abrasion-resistant SSIC seats, no metal parts in contact with the processed liquid and a wide range of options allow the CSS seals to be the best solution for every application. In case of liquid crystallization due to air contact, CDR offers plan 62.

CSS AND CSS-Q - product side:

Static Face	Rotating Face
Graphite	SSIC
SSIC	SSIC
Diamond SSIC	Diamond SSIC

CSS-Q - ambient side PLAN62:

Static Face	Rotating Face
SSIC	Graphite



CDC Double Mechanical Seal

Characteristics:

Applications where no leakage can be tolerated e.g. hazardous, toxic, inflammable media. For dirty, abrasive or polymerizing products and where media is unsuitable as a lubricant for inboard seal faces. When pump is operating under cavitation or low flow. Pumping ring as standard.

CDC - product side:

Static Face	Rotating Face
Graphite	SSIC
SSIC	SSIC
Diamond SSIC	Diamond SSIC

CDC - ambient side:

Static Face	Rotating Face
SSIC	Graphite



Custom-Made Pumps

Special arrangement on flanges

Magnetic Drive Upgrade of Existing Mechanical Seal Pumps

Taylor made design and construction of Vertical Pumps

Pumps with PN40 Casing

UTS-B IN LINE

Magnetic Drive Centrifugal Pump

Magnetic drive single stage centrifugal pumps in close coupled execution. Wetted parts in stainless steel. These pumps may be installed directly on the pipelines. Suction and discharge connections are in line.



CVN Vertical Centrifugal Pump

CVN are vertical axis centrifugal pumps made of PP or PVDF thermoplastic material (parts in contact with the process liquid). The typical applications of these pumps are in any industrial sector where they need to be transferred corrosive, toxic or dangerous liquids.



TMVN Magnetic Drive Centrifugal Pump

Magnetic drive single stage centrifugal pumps in vertical execution. Taylor made on Customer needs, wetted parts in PVDF. These pumps may be installed on the top of the hermetic vessel.

Suitable for applications with extremely dangerous liquids and with low NPSHA.

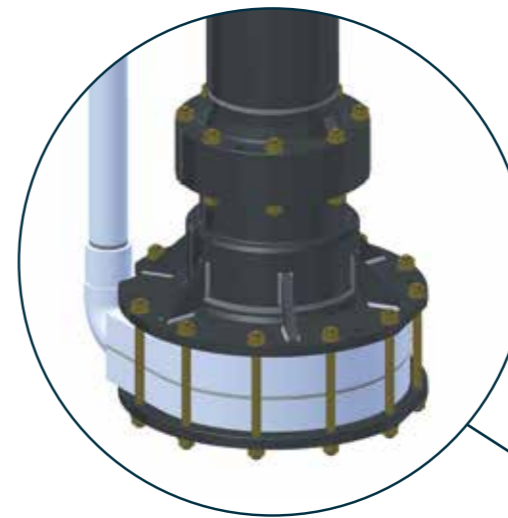

Detail of PVDF pump casing.

Centrifugal pumps

Discover the models of industrial pumps used in these sectors: Chemical, Industrial and Pharmaceutical. We work in close collaboration with distributors, in order to accurately understand customer requests by offering the most suitable product for their service.



Range of Applications	STN	ETN EVO	UTN-L	UTN-BL	DTN-L	DTN-BL	XTN-BL	XTS-B	UTS EVO	UTS-B EVO	ETS	UCL	UCL-B	CCL	CCN	HTN	HTS
Active substances		✓	✓	✓	✓	✓	✓	✓	✓	✓		✓					
Veterinary Medicines Phytopharmaceuticals		✓	✓	✓	✓	✓	✓		✓	✓							
Resins and glues								✓	✓	✓							
Active Substances, Catalysts and Fine Chemical Products		✓	✓	✓	✓	✓	✓		✓	✓		✓				✓	✓
Synthetic fibres								✓	✓	✓							✓
Acid production		✓	✓	✓		✓	✓		✓	✓		✓	✓		✓		
Solvent Regeneration									✓	✓							✓
Fertilizers			✓	✓													
Refineries		✓				✓			✓	✓	✓					✓	✓
Paper mill	✓										✓			✓			
Galvanic	✓										✓			✓	✓		
Detergents	✓										✓			✓		✓	
Food	✓													✓		✓	
Distillation									✓	✓							
Thermoregulation									✓	✓	✓						
Loading / Unloading Tanks		✓	✓	✓		✓			✓	✓							
Air treatment	✓	✓		✓								✓	✓	✓	✓		
Water treatment	✓	✓		✓								✓	✓	✓	✓		

Service

The advantages of CDR Pumps

Prompt delivery service:

Thanks to its long experience and its focus to the customer, CDR implemented a prompt delivery service that minimizes the impacts of an unexpected plant shutdown.

- CDR is one of the very few players on the market able to offer a prompt delivery service of mag drive pumps.
- CDR can provide, for a range of products and sizes, prompt delivery products within 3 working days from the order.
- The prompt delivery service is recommended for those companies that need to reconvert or expand their production plants in a short time, in order to meet the customer demand and support their growth.

Flexibility:

CDR flexibility, as well as its technical department know-how, allows the company to develop projects based on customer needs. In fact, CDR can design customized solutions that meet customer specifications.

Flexibility and responsiveness to the market needs, combined with the careful management of the after-sales process, make CDR one of the top players in its sector.

Service:

Thanks to our "customer oriented" culture, during the last years CDR decided to invest a lot on customer service operations. CDR focuses on 4 essentials points:

- Solve all the problems the customer may face in the use and maintenance of the pumps in the fastest way possible and with the due accuracy.
- Create a confidential relationship between supplier and customer to get a non-stop growing of the company know-how. CDR designs and produces pumps, but the continuous improvement is possible only thanks to our customers' feedback.
- Make our workshop more and more efficient thanks to a continuous training of our specialized workers. Reparation timing are very short thanks to a strategic spare parts stock.
- Availability of a strategic spare parts stock to solve possible emergencies and avoid unpleasant downtimes.

Furthermore, for each single customer CDR can study a specific preventive maintenance program with the aim of reducing maintenance costs and plant shutdown.

Our Sales Office can reply within 24 hours to spare parts inquiries to provide quick responses and deliveries to all our customers, anywhere in the world.

Thanks to its technicians, CDR can provide any kind of technical consultancy as well as assistance and support.



CDR Pompe

Via Raffaello Sanzio, 57
20021 Bollate (MI)
Tel. +39 02 9901941

www.cdrpompe.com

Technical characteristics:

The data and technical characteristics shown in the General Catalogue are not binding. CDR Pompe SRL reserves the right to implement changes without notice. Therefore the data, the size, performance and any other information reported are indicative and not binding. For any technical details you can request the product update form.