

tapflo®

CTX HIGH PERFORMANCE CENTRIFUGAL PUMPS

2025 | 1



» All about your flow®

www.tapflo.com

CTX High Performance Centrifugal Pumps

the premium pump series from Tapflo with superior performance

Thanks to the robust construction and a compact and reliable design, CTX pumps assure long term failure-free operation thus short downtimes.

CTX pumps are available in hygienic and industrial execution.

CTX H - hygienic execution

- » **wetted parts** electropolished to **Ra<0.8 µm** as standard (**Ra<0.5 µm** on request)
- » **external surfaces** glass blasted to **Ra<3.2 µm**
- » single and double mechanical seals and elastomers **FDA and EC1935 approved**
- » **hygienic connections** with DIN 11851 as standard

CTX I - industrial execution

- » **wetted parts** and **external surfaces** glass blasted to **Ra<3.2 µm** as standard
- » **industrial connections** with EN1092-1 flange as standard



Certificates may vary depending on material execution of particular product.

Features

- ✓ High efficiency
- ✓ Hygienic & Industrial execution
- ✓ Single or double mechanical seal
- ✓ Low noise, low vibration
- ✓ Adjusted (trimmed) impeller
- ✓ Robust construction, easy maintenance, less downtime
- ✓ Modular design concept
- ✓ Low NPSHr

Working principle

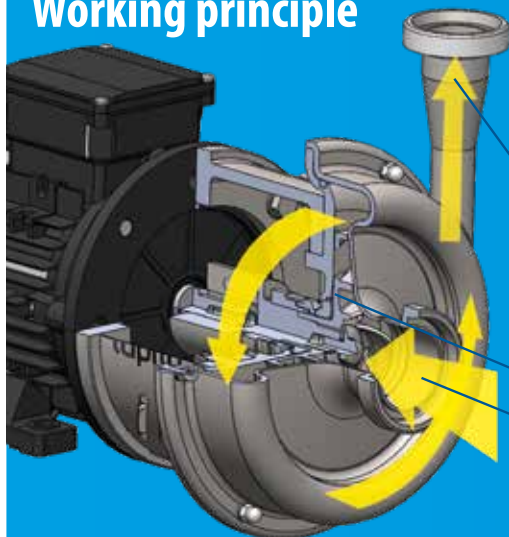

IMPELLER

The impeller is connected to a motor through a drive shaft and rotated at high speed.

SUCTION

The fluid enters the pump housing alongside the impeller rotation axis which provides centrifugal acceleration to the liquid.

DISCHARGE

The fluid flows radially outward through the pump casing, from where it exits into the discharge piping.

DISCHARGE

IMPELLER

SUCTION

Wide range of applications (CTX H & CTX I)

CTX H

Industries:

- » dairy
- » ice cream
- » beverage
- » food
- » pharma
- » cosmetics
- » brewery and winery

Applications:

diary,
fats,
juices,
alcohol,
semi products,
food additives,
ingredients for cosmetic and pharmaceutical,
products in explosive and safe zones,

mild and aggressive chemicals,
hot and cold liquids,
suspensions and emulsions,
cleaning and washing agents,
wastewater,
feeding and unloading of storage tanks,
containers, filters, sumps,
powering process equipment, dosing systems,
dispensing units,



CTX I

Industries:

- » chemical,
- » mining,
- » oil & gas,
- » packaging,
- » printing,
- » automotive,
- » machinery,
- » wastewater treatments plants,

Applications:

oils,
fuels,
solvents,
concentrated or diluted acids and alkalis in
explosives and safe zones,
mild and aggressive chemicals,
hot and cold liquids,

suspensions and emulsions,
cleaning and washing agents,
wastewater,
cooling and heating media,
feeding and unloading of storage tanks,
containers, filters, sumps,
powering process equipment, dosing systems,
dispensing units, test rigs,



Modular product concept

for diverse application conditions

The modular product concept of the CTX pump series allows bigger flexibility in terms of the adaptation to different application conditions. This also means higher versatility of the pump with quick and easy upgrade options. The interchangeability of the parts between pump types and sizes makes the pump maintenance cheaper and easier to manage.

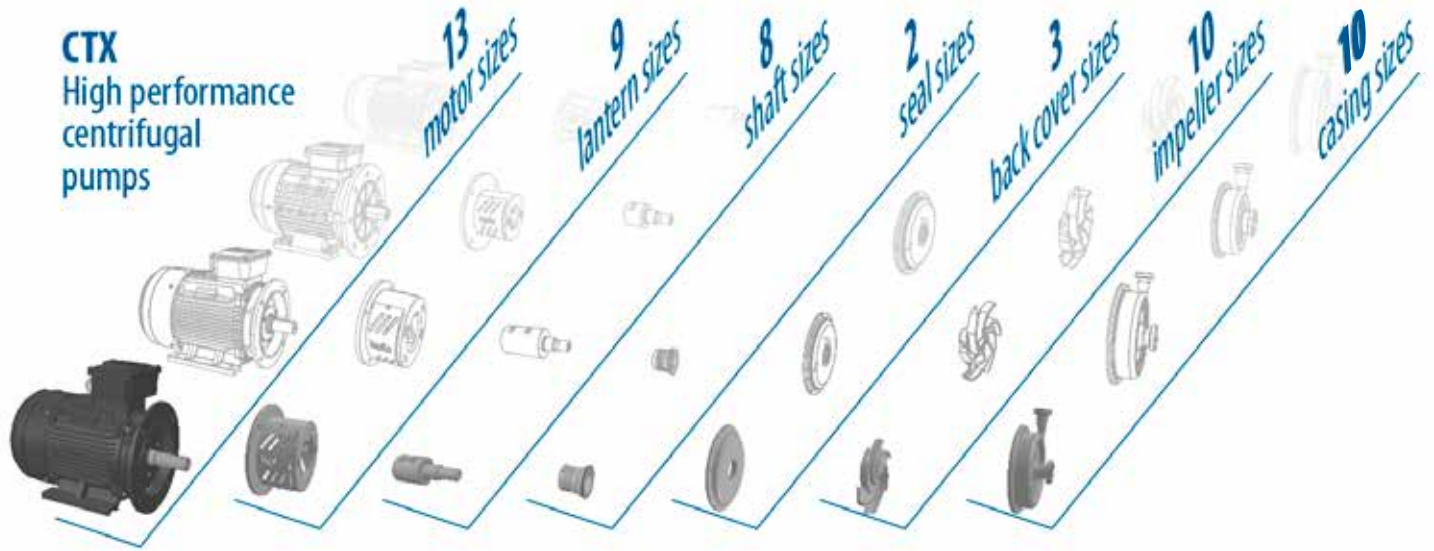

Open impeller

CTX series pumps have **robust, high efficiency** and **low NPSH design** open impellers.

The adjustment of CTX pumps performance to concrete duty points or ranges could be done by **impellers trimming** at constant speeds or by pump speed adjustment at constant impeller diameters.

CTX range open impellers are easily cleanable and suitable for pumping liquids also with **suspended solids**.

Pump size	Impeller diameter	
	Max.	Min.
CTX 40-165	165	120
CTX 50-145	145	115
CTX 50-200	200	160
CTX 65-175	175	130
CTX 65-230	230	170
CTX 65-240	240	190
CTX 80-205	205	155
CTX 80-212	212	160
CTX 80-260	260	195
CTX 100-230	230	170



Designed for quality performance

Hygienic mechanical seal arrangement

Single mechanical seal

The seal spring is not in contact with the medium what makes seal wetted area fully cleanable.

Double mechanical seal

The seal is applied:

- when the fluid and its vapors are hazardous to the operator or environment, and must be contained
- when aggressive media are used at high pressures or temperatures
- for many polymerizing, crystalizing media.

Seal in back-to-back arrangement is installed in separate chamber.



Variety of connections

CTX H Hygienic execution - DIN 11851, DIN 32676 and other (on request).

CTX I Industrial execution - flanged connections according to EN 1092-1 type11, ANSI 150 Lbs. Other connection types on request.

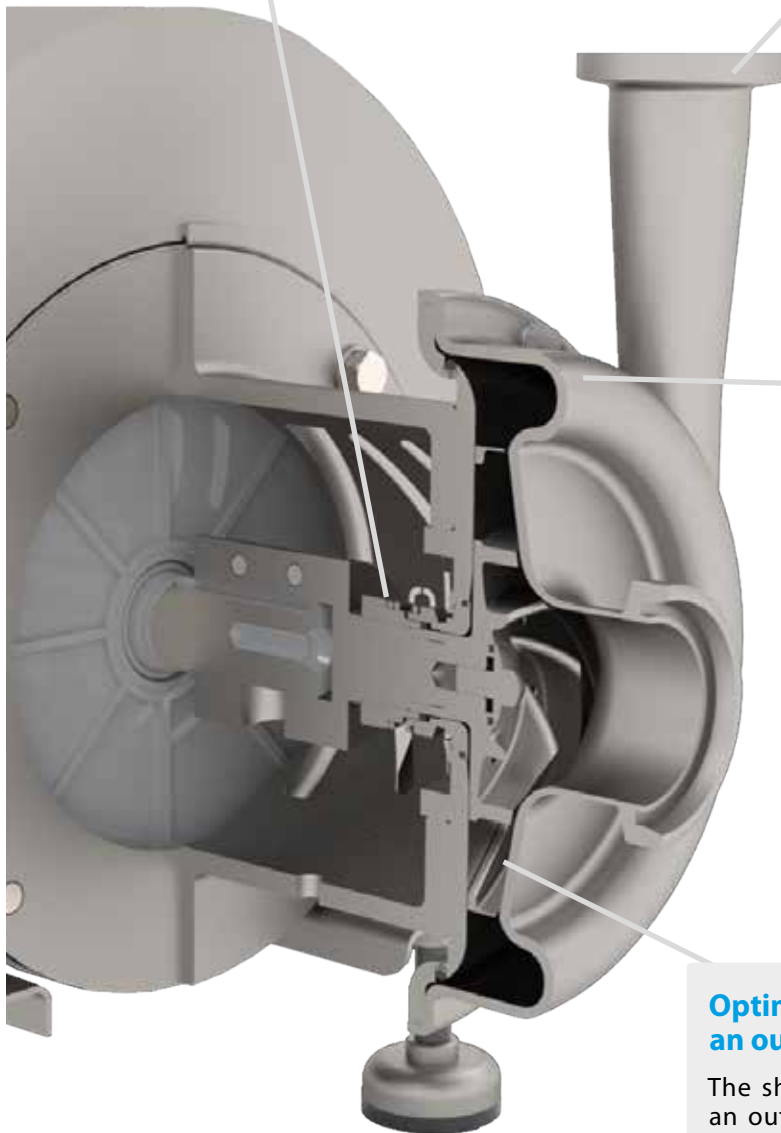

Casing available in Ra<0.5

» Hygienic **CTX H wetted parts** electropolished to **Ra<0.8 µm** as standard (**Ra<0.5 µm** on request), **external surfaces** glass blasted to **Ra<3.2 µm**.



» Industrial **CTX I** glass blasted **Ra<3.2 µm** of the wetted parts and the external surfaces.



Optimized casing and impeller design for an outstanding performance

The shapes of the chamber and the impeller are an outcome of an advanced multivariate analysis and numerous performance tests.

Both these elements were designed and optimized to deliver the most efficient working parameters.

CTX H- hygienic series

Materials, data and limits

Casing	Stainless steel AISI 316L electro polished Ra<0.8
Open impeller	Stainless steel AISI 316L electro polished Ra<0.8
Mechanical seal	Single, SiC/carbon (std) or SiC/SiC, FDA approved Double, SiC/carbon (std) or SiC/SiC, FDA approved
O-rings	EPDM, FKM, NBR (all FDA approved)
Motor*	IEC standard, 3-phase, 2-pole/4-pole, IP55
Pressure rating @ 20°C	PN10 – CTX 40-165, CTX 50-145, CTX 50-200, CTX 65-175 PN16 – CTX 65-230, CTX 65-240, CTX 80-205, CTX 80-212, CTX 80-260, CTX 100-230
Liquid temp.	-10 °C ... +120 °C (140 °C for short periods during SiP)
Ambient temp.	-20 °C ... +40 °C
Viscosity	max ~150 cSt

*other motor options available on request



Connection dimensions

Model	DIN 11851 thread (std.)		DIN 32676 clamp		SMS3017 clamp		SMS 1145 thread		RJT thread	
	Inlet	Outlet	Inlet	Outlet	Inlet	Outlet	Inlet	Outlet	Inlet	Outlet
CTX 40-165	DN40	DN32	DN40	DN32	38	33.7	38	38	1 ½"	1 ¼"
CTX 50-145	DN50	DN40	DN50	DN40	51	38	51	38	2"	1 ½"
CTX 50-200	DN50	DN40	DN50	DN40	51	38	51	38	2"	1 ½"
CTX 65-175	DN65	DN50	DN65	DN50	63.5	51	63.5	51	2 ½"	2"
CTX 65-230	DN65	DN50	DN65	DN50	63.5	51	63.5	51	2 ½"	2"
CTX 65-240	DN65	DN40	DN65	DN40	63.5	38	63.5	38	2 ½"	1 ½"
CTX 80-205	DN80	DN50	DN80	DN50	76.1	51	76	51	3"	2"
CTX 80-212	DN80	DN65	DN80	DN65	76.1	63.5	76	63.5	3"	2 ½"
CTX 80-260	DN80	DN65	DN80	DN65	76.1	63.5	76	63.5	3"	2 ½"
CTX 100-230	DN100	DN80	DN100	DN80	101.6	76.1	101.6	76	4"	3"

Options and special executions



Built-on inverter

This is **easiest and most flexible way of changing pump working parameters**. In addition, the pump and motor are protected from overloading and a soft-start function is included.



Hygienic connections

The hygienic CTX H pumps are equipped with a wide range of connections such as: **DIN 11851, DIN 32676, SMS3017, SMS 1145, RJT and other**.



Adjustable feet

The solution allows **easy cleaning** of the surface underneath the pump. It can also prove useful when there is a need to move the pump to a different location.



Hygienic shroud

The hygienic motor shroud in AISI 304L **protects the motor against flooding**, deposition of dirt, from spraying water during pump cleaning procedure.



Inducer

The inducer increases inlet pressure thus lowering the NPSHr of the pump. This option is very **easy to accommodate even in existing pumps** as only the inducer has to be screwed onto the impeller.

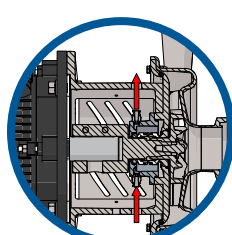

Double mechanical seal

This option is utilized in cases of liquids with high abrasive solids content, aggressive or polymerizing liquids. It allows **easy leakage control**. Utilizes pressurized quench liquid. Available with SiC/Carbon seal faces at atmospheric side and SiC/SiC and SiC/Carbon on liquid side.

CTX I- industrial series

Materials, data and limits

Casing	Stainless steel AISI 316L sand blasted Ra<3.2
Open impeller	Stainless steel AISI 316L electro polished Ra<3.2
Mechanical seal	Single, SiC/carbon (std) or SiC/SiC, FDA approved Double, SiC/carbon (std) or SiC/SiC, FDA approved
O-rings	EPDM, FKM, NBR (all FDA approved)
Motor*	IEC standard, 3-phase, 2-pole/4-pole, IP55
Pressure rating @ 20°C	PN10 – CTX 40-165, CTX 50-145, CTX 50-200, CTX 65-175 PN16 – CTX 65-230, CTX 65-240, CTX 80-205, CTX 80-212, CTX 80-260, CTX 100-230
Liquid temp.	-10 °C ... +120 °C (140 °C for short periods during SiP)
Ambient temp.	-20 °C ... +40 °C
Viscosity	max ~150 cSt

*other motor options available on request



Connection dimensions

Model	BSPT male thread		EN1092-1 flange (std.)		ANSI 150 Lbs flange	
	Inlet	Outlet	Inlet	Outlet	Inlet	Outlet
CTX 40-165	1 ½"	1 ¼"	DN40	DN32	1 ½"	1 ¼"
CTX 50-145	2"	1 ½"	DN50	DN40	2"	1 ½"
CTX 50-200	2"	1 ½"	DN50	DN40	2"	1 ½"
CTX 65-175	2 ½"	2"	DN65	DN50	2 ½"	2"
CTX 65-230	2 ½"	2"	DN65	DN50	2 ½"	2"
CTX 65-240	2 ½"	1 ½"	DN65	DN40	2 ½"	1 ½"
CTX 80-205	3"	2"	DN80	DN50	3"	2"
CTX 80-212	3"	2 ½"	DN80	DN65	3"	2 ½"
CTX 80-260	3"	2 ½"	DN80	DN65	3"	2 ½"
CTX 100-230	4"	3"	DN100	DN80	4"	3"

Options and special executions



Built-on inverter

This is **easiest and most flexible way of changing pump working parameters**. In addition, the pump and motor are protected from overloading and a soft-start function is included.



Adjustable feet

The solution allows **easy cleaning** of the surface underneath the pump. It can also prove useful when there is a need to move the pump to a different location.



Inducer

The inducer increases inlet pressure thus lowering the NPSHr of the pump. This option is very **easy to accommodate even in existing pumps** as only the inducer has to be screwed onto the impeller.



Industrial flanged connections

The industrial CTX I pumps are equipped with connections according to **EN 1092-1 type11, ANSI 150 Lbs**. Other connection types on request



Mounting brackets

Complete pump unit may be assembled on a baseplate **which can be firmly, permanently fixed to the foundation**

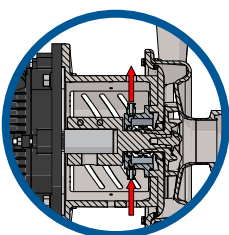

Double mechanical seal

This option is utilized in cases of liquids with high abrasive solids content, aggressive or polymerizing liquids. It allows **easy leakage control**. Utilizes pressurized quench liquid. Available with SiC/Carbon seal faces at atmospheric side and SiC/SiC and SiC/Carbon on liquid side.

Performance curves

The performance curves are based on water.

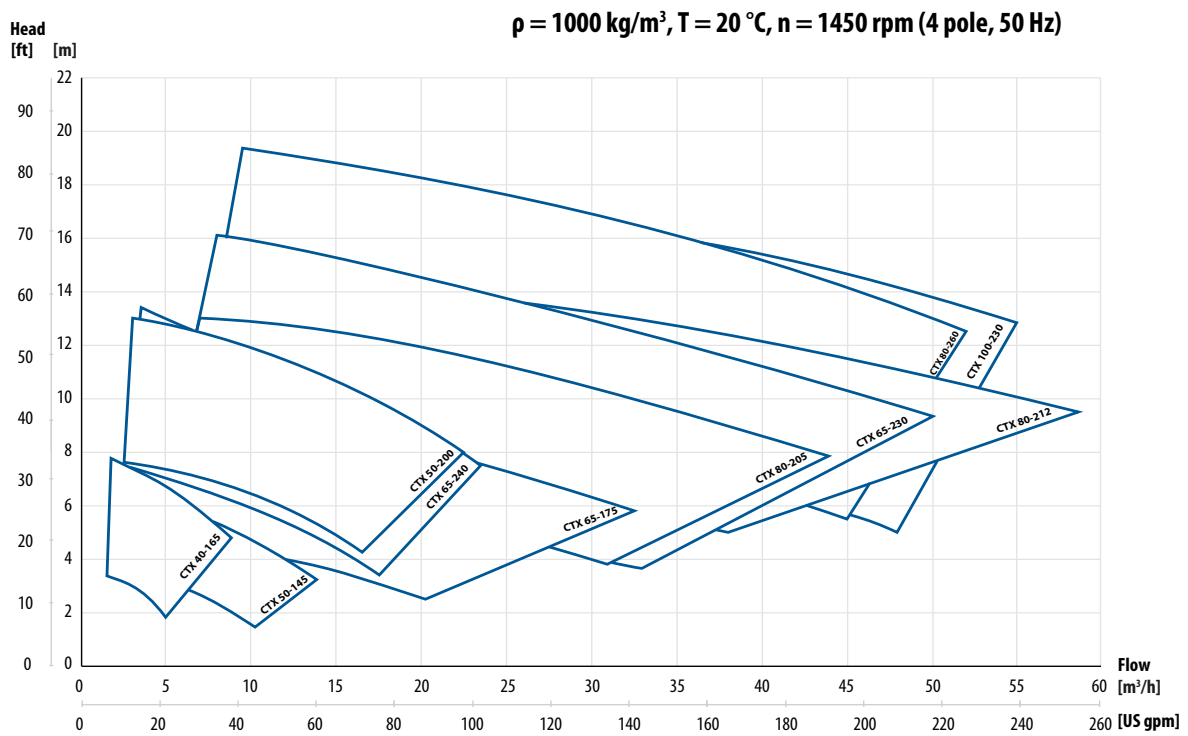
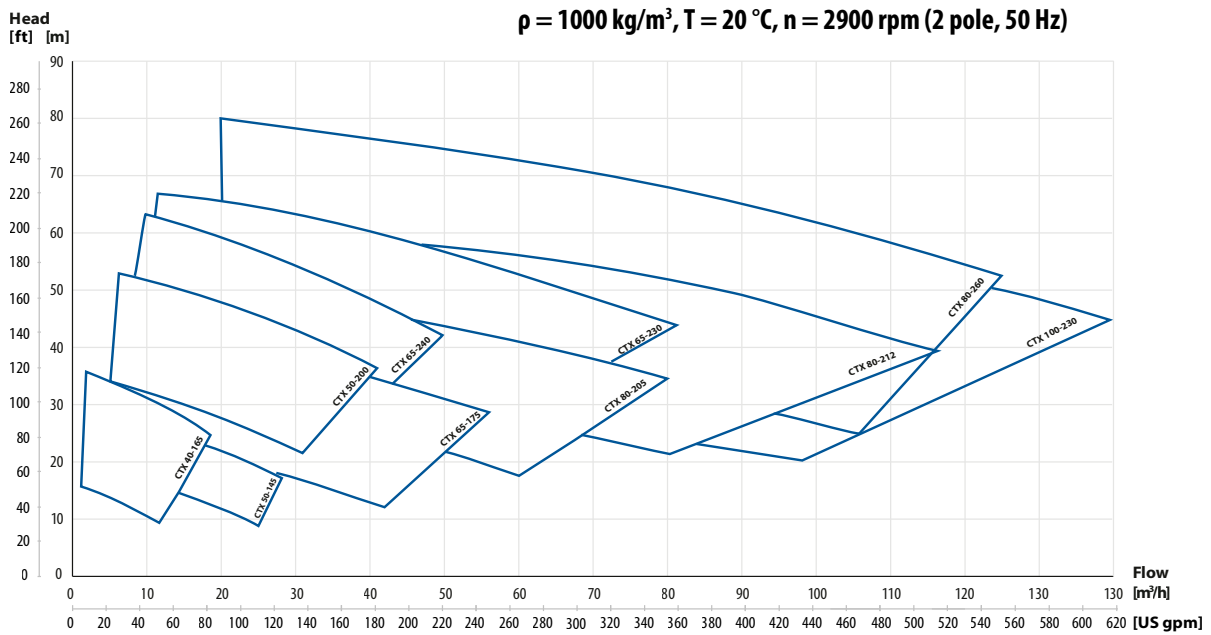

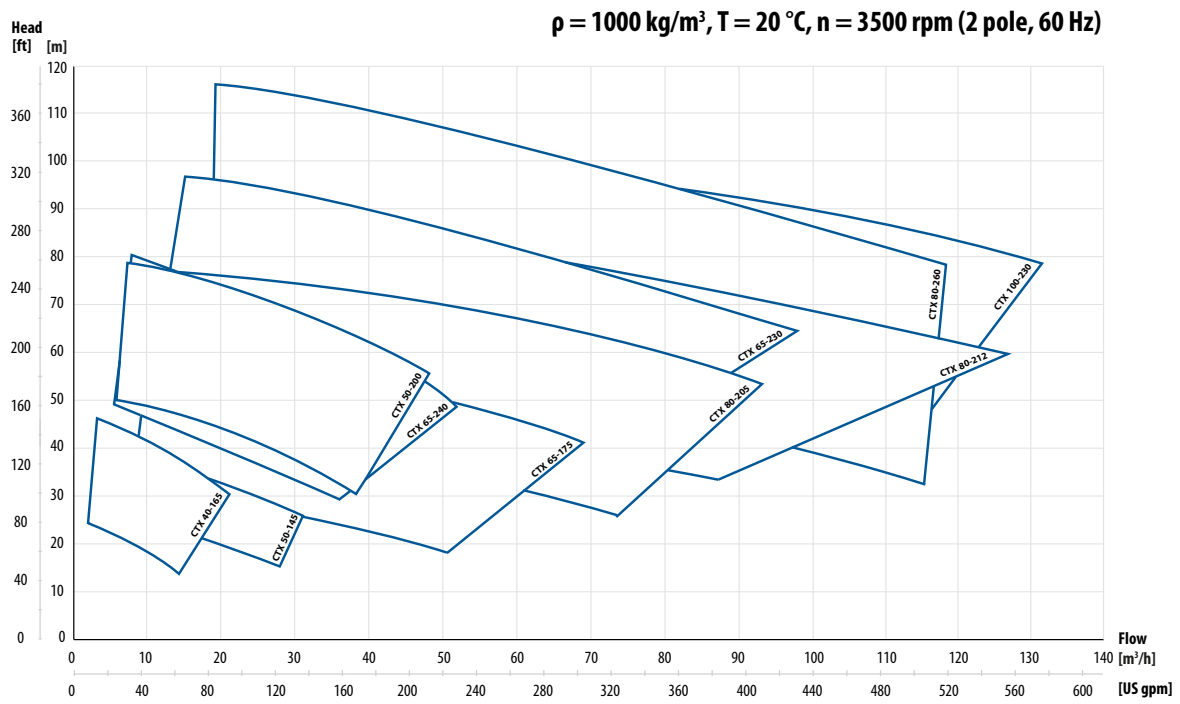

Available motor powers

2-pole motor	40-165	50-145	50-200	65-175	65-230	65-240	80-208	80-212	80-260	100-230
Motor power [kW]	1.5; 2.2; 3; 4; 5.5; 7.5		3; 4; 5.5; 7.5; 11; 15; 18.5		5.5; 7.5; 11; 15; 18.5; 22; 30; 37; 45					
4-pole motor	40-165	50-145	50-200	65-175	65-230	65-240	80-208	80-212	80-260	100-230
Motor power [kW]	1.5		2.2		5.5					

CTXS - self-priming series

hygienic and industrial

Thanks to its self-priming capability, the pump can be used in situations where a dry suction lift is necessary. As the standard CTX pump is not capable of generating negative pressure, by a simple modification, we can allow the pump to lift the liquid from up to 5 m. To maintain a liquid ring inside the pump after the initial filling, the return pipe will re-circulate the liquid from the discharge side of the pump.



EN 10204



Certificates may vary depending on material execution of particular product.

Features



Self-priming - up to 5 m



Hygienic and Industrial solution



Easy maintenance and cleaning



Simple and compact design

Comparison of standard and self-priming execution.

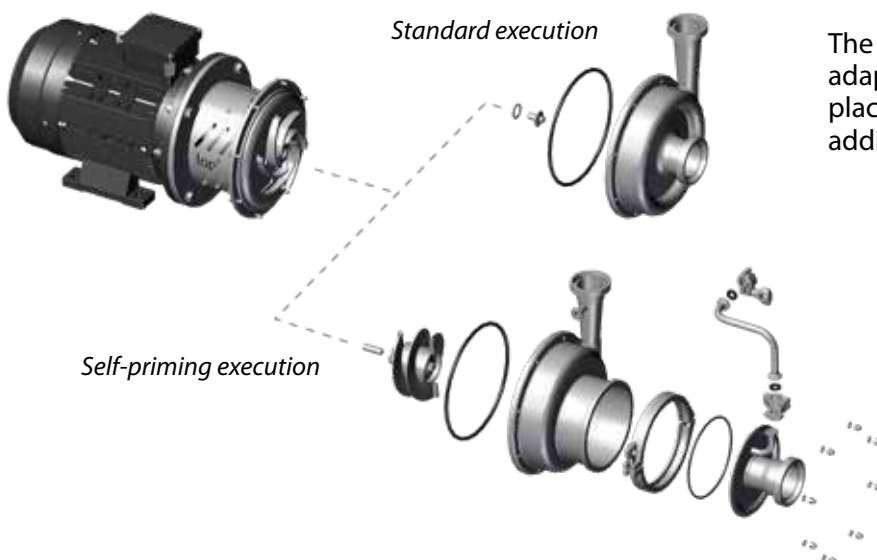

The self-priming option is easy to adapt in existing pumps just by replacing the front cover assembly and adding the air screw.

CTX Pump code

I. Tapflo centrifugal pump

CTX

II. Pump execution

H

III. Pump size

65-240

IV. Impeller diameter

220

V. Pump options

1SSV3T

VI. Motor power / IEC motor size

75

VII. Motor options

M

Performance curves

The performance curves are based on water.

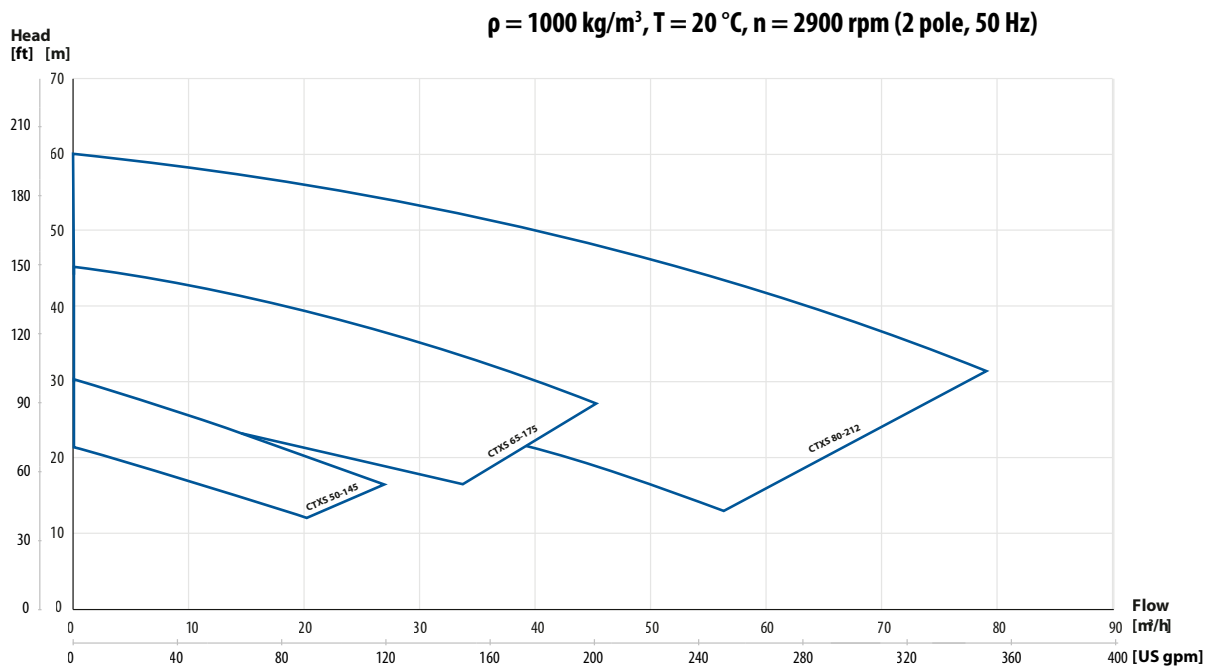

Mobile Pump Solutions

solve the problem of spread technological processes

The portability of the units allows easy movement to various locations. This means almost limitless application.

Mobile pump units are available in both hygienic and industrial designs. The great advantage is the compatibility with the majority of Tapflo centrifugal pumps range.

Moreover, it is possible to compose the trolley to your own needs by using a number of accessories such as ON-OFF switches, frequency inverters, or cable holders.

Hygienic Trolleys

- » Stainless steel polished drip tray
- » Valve for drainage
- » 3 sizes available

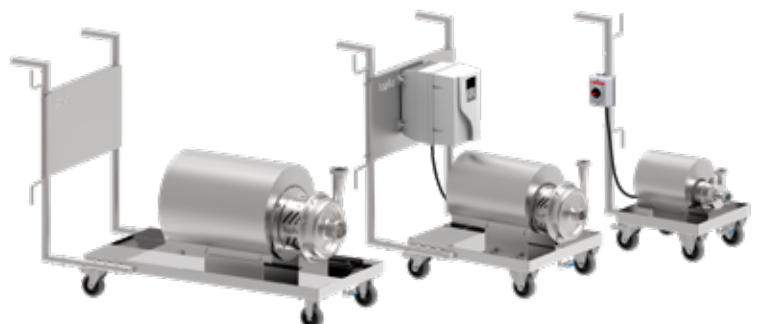

Industrial Trolleys

- » Stainless steel construction
- » Compact and strong baseplate
- » 3 sizes available



Sweden

Filaregatan 4 | S-442 34 Kungälv

Tel: +46 303 63390

Fax: +46 303 19916

E-mail addresses:

Commercial questions: sales@tapflo.com

Orders: order@tapflo.com

Tech support: support@tapflo.com

We began our journey in 1980 in Kungälv, a small town on the Swedish west coast, as a family company with an ambition to one day become a global player on the pump market.

Since the foundation, we have taken pride in delivering a wealth of knowledge and passion for pumps to the industry, whilst supplying a wide range of premium products for various industrial applications.

Over the years, the company has developed into a global Tapflo Group with branches and distributors present in nearly every region of the world.

One thing did not change - we are still a family company.

Tapflo products and services are available worldwide.

Tapflo is represented by own Tapflo Group Companies and carefully selected distributors assuring highest Tapflo service quality for our customers' convenience.

AUSTRALIA | AUSTRIA | AZERBAIJAN | BAHRAIN | BELGIUM | BOSNIA | BRAZIL | BULGARIA | CANADA | CHILE | CHINA | COLOMBIA | CROATIA | CZECH REPUBLIC | DENMARK | ECUADOR | EGYPT | ESTONIA | FINLAND | FRANCE | GEORGIA | GERMANY | GREECE | HONG-KONG | HUNGARY | ICELAND | INDIA | INDONESIA | IRELAND | ISRAEL | ITALY | JAPAN | JORDAN | KAZAKHSTAN | KUWAIT | LATVIA | LIBYA | LITHUANIA | MACEDONIA | MALAYSIA | MEXICO | MONTENEGRO | MOROCCO | NETHERLANDS | NEW ZEALAND | NORWAY | OMAN | PHILIPPINES | POLAND | PORTUGAL | QATAR | ROMANIA | SAUDI ARABIA | SERBIA | SINGAPORE | SLOVAKIA | SLOVENIA | SOUTH AFRICA | SOUTH KOREA | SPAIN | SWEDEN | SWITZERLAND | TAIWAN | THAILAND | TURKEY | UKRAINE | UNITED ARAB EMIRATES | UNITED KINGDOM | USA | UZBEKISTAN | VIETNAM

Tapflo Group Companies

Australia

Tapflo Oceania (Pty) Ltd.
Tel: +61 1800303633
sales@tapflo.com.au

China

Tapflo (Wuxi) Pumps Co. Ltd.
Tel: +86 51082417072
sales@tapflo.cn

Ireland

Tapflo Ireland Ltd.
Tel: +353 12011911
info@tapflo.ie

Poland

Tapflo Sp. z o.o.
Tel: +48 609 995 500
info@tapflo.pl

Spain

Tapflo Ibérica S.L.
Tel: +34 918093182
avives@tapfloiberica.es

Uzbekistan

Tapflo Uzbekistan
Tel: +998 712370940
sales@tapflo.uz

Austria

Tapflo GmbH
Tel: +43 73227292910
sales@tapflo.at

Croatia

Tapflo d.o.o.
Tel: +385 914884666
sales@tapflo.hr

Italy

Tapflo Italia S.r.l.
Tel: +39 0362306528
info@tapfloitalia.com

Qatar

Tapflo Gulf General Trading Co. L.L.C
Tel: +971 58 582 3630
sales@tapfloqatar.com

South Africa

Tapflo (Pty) Ltd.
Tel: +27 317015255
sales@tapflo.co.za

Bahrain

Tapflo Gulf General Trading Co. L.L.C
Tel: +971 58 582 3630
sales@tapfloqatar.com

Czech Republic

Tapflo s.r.o.
Tel: +420 513033920
tapflo@tapflo.cz

Japan

Tapflo Japan K.K.
Tel: +81 362403510
tapflojp@tapflo.co.jp

Romania

S.C. Tapflo Rom. S.r.l.
Tel: +40 213451255
sales@tapflo.ro

Sweden

Tapflo AB
Tel: +46 (0)30314050
info@tapflo.com

Baltic States

Tapflo SIA
Tel: +371 67472205
sales@tapflo.lv

Denmark

Tapflo Danmark ApS
Tel: +45 36454600
info@tapflo.dk

Kazakhstan

Tapflo LLP
Tel: +7 727 327 83 47
sales@tapflo.kz

Saudi Arabia

Tapflo Gulf General Trading Co. L.L.C
Tel: +971 58 582 3630
sales@tapfloqatar.com

Turkey

Tapflo Makina Ltd.
Tel: +90 2164673311
sales@tapflo.com.tr

Belgium

Tapflo Benelux B.V.
Tel: +31 (0) 6 21850664
info@tapflo.nl

France

Sarl Tapflo France
Tel: +33188788240
info@tapflo.fr

Kuwait

Tapflo Gulf General Trading Co. L.L.C
Tel: +971 58 582 3630
sales@tapfloqatar.com

Serbia

Tapflo d.o.o.
Tel: +381 21445808
sales@tapflo.rs

Ukraine

Tapflo LLC
Tel: +380 442226844
sales@tapflo.ua

Bulgaria

Tapflo EOOD
Tel: +359 886 124 937
office@tapflo.bg

Hungary

Tapflo Kft.
Tel: +36 30148 8551
office@tapflo.hu

Netherlands

Tapflo Benelux B.V.
Tel: +31 (0) 6 21850664
info@tapflo.nl

Slovakia

Tapflo s.r.o.
Tel: +421 911137883
tapflo@tapflo.sk

United Arab Emirates

Tapflo Gulf General Trading Co. L.L.C
Tel: +971 58 582 3630
sales@tapfloqatar.com

Canada

Tapflo Canada
Tel: +1 514 409 8380
office@tapflo.ca

India

Tapflo Fluid Handling India Pvt Ltd.
Tel: +91 9028574063
enquiry@tapflo.in

Oman

Tapflo Gulf General Trading Co. L.L.C
Tel: +971 58 582 3630
sales@tapfloqatar.com

Slovenia

Tapflo d.o.o.
Tel: +386 68613474
sales@tapflo.hr

United Kingdom

Tapflo (UK) Ltd.
Tel: +44 2380252325
sales@tapflo pumps.co.uk



If your country is not listed please visit www.tapflo.com/en/contact