

Additional sealing step in PTFE pumps housing

Starting from serial no. 1510-.... Tapflo introduces additional sealing step in T50 T, TX50 T, T100 T, TX100 T, T200 T, TX200 T, T400 T; TX400 T pumps housings.

Old design of housing

New design of housing

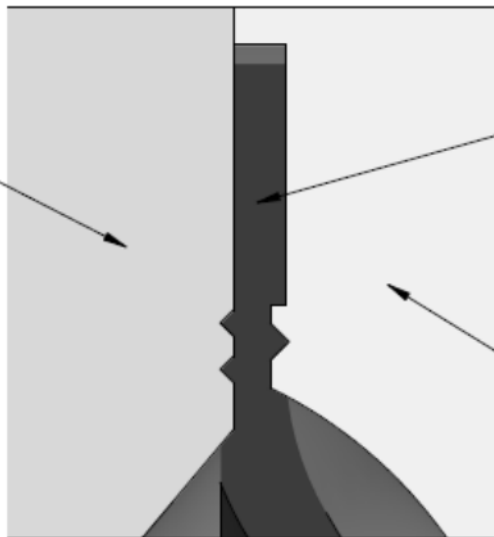
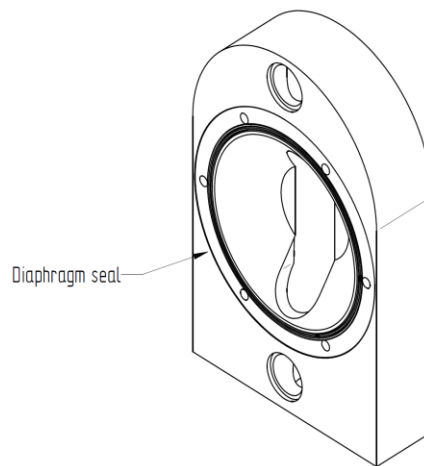
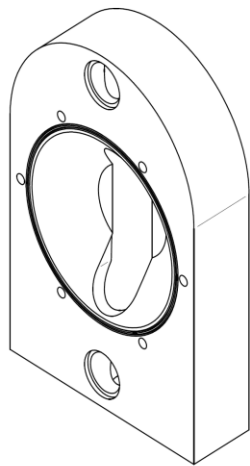

Housing

Diaphragm

Centerblock

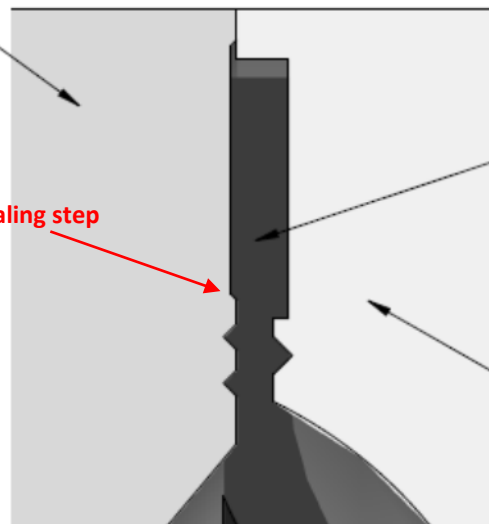

Diaphragm

Centerblock

Reason of the change:

Increased PTFE housings relaxation over the time was observed after pump assembly. As a result, more frequent pump re-tightening is required, when compared with PE housings. To avoid such situation additional step in PTFE housing was introduced.

Benefits:

Additional sealing step provides better seal of diaphragm between pump housing and centerblock,

Ordering pumps:

No changes when ordering pumps.

Ordering spare parts:

No other parts besides pump housing will be changed. Old and new design housings are interchangeable. Codes for new type of housings remain the same.