

PNEUMATIC DIAPHRAGM FAILURE MONITORING SYSTEM (PDFM) (only for TB... pumps)

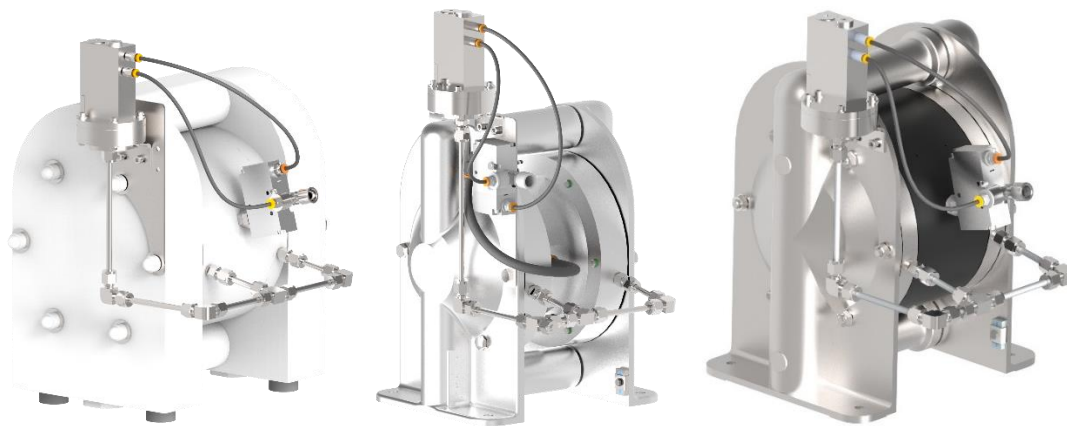

Pneumatic Diaphragm Failure Monitoring system stops the pump in case of a breach in the pump's primary diaphragm.

The task of this system is to monitor pressure value between primary and additional pump's diaphragms. In case of detecting a breach in the primary diaphragm, it turns off the pump by cutting off the compressed air supply.

The task of the Pneumatic monitoring system is to prevent from leakages, that might be dangerous for the operators and the environment.

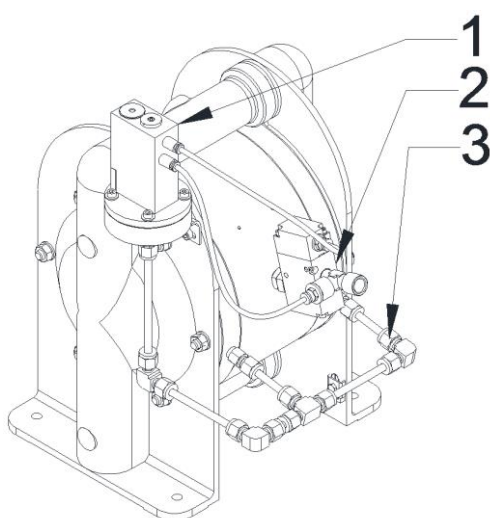

Product code:

PDFM-xxx

Pump size ————

Spare parts:

1	Guardian	GRDB-xxx
2	Pneumatic set	PNEK-xxx
3	Wet part set	WPRT-xxx

