

Steinle Filter Press Pump Series

edition 2020 rev 1

Original Instruction



Read this instruction manual carefully,
before you install and operate the pump



Pump models:

FP/FH 25

FP/FH 40

FP/FH 50

FP/FH 80



CONTENTS

0. GENERAL	6
0.1. Introduction	6
0.2. Warning symbols	6
0.3. Qualification and training of personnel	6
1. INSTALLATION	7
1.1. Operation principle	7
1.2. Receiving inspection	8
1.3. Lifting and transportation	8
1.4. Storage	9
1.5. Foundation	10
1.6. Suction and discharge piping	10
1.6.1. Connection of suction pipe	10
1.6.2. Connection of discharge pipe	10
1.7. Health and safety	10
1.7.1. Protection	10
1.7.2. Air pressure	11
1.7.3. Noise level	11
1.7.4. Temperature hazards	11
1.8. Air connection	11
1.8.1. Air treatment system	11
1.8.2. Air quality classes	12
1.9. Installation example	13
1.10. Recommended installations	13
1.10.1. Flooded	13
1.10.2. Self-priming	13
1.11. Electric Connection	13
1.11.1. 24 V DC (Standard)	14
1.11.2. 230 V AC	14
1.11.3. Connection diagram	14
1.11.3.1. 24V DC power supply - Standard	14
1.11.3.2. 230V AC power supply	15
1.11.3.3. 24V DC power supply with diaphragm control unit	15
1.11.3.4. 230V AC power supply with diaphragm control unit	16
1.12. Diaphragm control unit for FP/FH Pumps Series	16
1.12.1. Installation of the sensors	16

CONTENTS

1.12.2. Procedure od adjustment.....	16
1.12.3. Control unit signals.....	17
2. OPERATION	18
2.1. Before starting the pump.....	18
2.2. Starting and operation	18
2.2.1. Dry running	18
2.2.2. Optimization of the pump lifetime	18
2.3. Pump stopping.....	19
2.4. Residual risks.....	19
2.5. Disposal after expiration of the expected lifetime	19
2.6. Waste of electrical and electronic equipment (WEEE) directive	19
2.7. Actions in emergency	19
3. MAINTENANCE	21
3.1. When the pump is new or reassembled.....	21
3.1.1. Performance test.....	21
3.2. Routine inspection	21
3.3. Complete inspection.....	21
3.4. Location of faults	22
3.5. FP/FH 25 – Disassembly of the pump	23
3.5.1. Before the disassembly procedure	23
3.5.2. Disassembly procedure.....	23
3.5.3. Test run	27
3.6. FP/FH 40-80 – Disassembly of the pump.....	28
3.6.1. Before the disassembly procedure	28
3.6.2. Disassembly procedure.....	28
3.7. FP/FH – assembly of the pump.....	32
3.8. Changing the parts.....	33
3.8.1. Changing seals.....	33
3.8.2. Changing the piston and the cylinder	33
3.8.3. Changing the hose diaphragms	33
3.8.3.1. Suction Side	33
3.8.3.2. Discharge Side	34
3.9. Filling of Hydraulic Liquid	34
3.9.1. Pump is flooded from the suction side	34
3.9.2. Pump is not flooded	35
3.9.3. Changing stroke sensors	35

CONTENTS

3.9.4. Test run	35
4. SPARE PARTS	36
4.1. FP-FH 25 – Spare parts drawings.....	36
4.2. FP-FH 25 – Spare parts list	39
4.3. FP-FH 40 – Spare parts drawing	41
4.4. FP-FH 40 – Spare parts list	44
4.5. FP-FH 50/80 – Spare parts drawing.....	47
4.6. FP-FH 50/80 – Spare parts list.....	50
4.7. Stocking recommendation	53
4.8. How to order parts.....	54
4.9. Pump code	55
5. DATA	56
5.1. Capacity curves.....	56
5.2. Capacity changes.....	57
5.3. Dimensions	57
5.4. Technical data	59
5.5. Tightening torques	60
5.6. Permitted manifold loads.....	61
6. WARRANTY	62
6.1. Warranty form.....	62
6.2. Returning parts	63
6.3. Warranty.....	63

DECLARATION OF CONFORMITY 01/EC/FP/2019

Series:

FP/FH 25(...); FP/FH 40(...); FP/FH 50(...); FP/FH 80(...)

Serial numbers:

2019 - ... (from 1907-...)

Manufactured by:

Tapflo AB

Filaregatan 4

4434 Kungälv, Sweden

This declaration of conformity is issued under the sole responsibility of the manufacturer.

Object of declaration: **Filter Press Pumps**

The object of the declaration described above is in conformity with the relevant Union harmonization legislation:

- Directive 2006/42/EC of European Parliament and of the Council of 17 May 2006 on machinery, amending Directive 95/16/EC;

Mr Michał Śmigiel is authorized to compile the technical file.

Tapflo Sp. z o.o.
ul. Czatkowska 4b
83-110 Tczew

Signed for and on behalf of
Tapflo AB



Håkan Ekstrand
Managing Director

Tapflo AB, 01.07.2019r

0. GENERAL

0. GENERAL

0.1. Introduction

The FP/FH Air Operated Filter Press Pump range is a complete series of pumps for industrial applications. The pumps are designed to be safe, simple and easy to use and maintain. The construction is seal-less and without rotating parts. The pumps are suitable for a variety of duties in filter press installations.

With proper attention to maintenance, Tapflo Pumps will give efficient and trouble-free operation. This instruction manual will familiarise operators with detailed information about installing, operating and maintaining of the pump.

The design and function allow the user a straightforward pressing of slurries.

When installing, operating and maintaining of the pump unit you must strictly follow the IOM manual. Otherwise injury or life hazard may occur.

0.2. Warning symbols

The following warning symbols are present in this instruction manual. This is what they say:



This symbol stands next to all safety instructions in this instruction manual where danger to life and limb may occur. Observe these instructions and proceed with utmost caution in these situations. Inform also other users of all safety instructions. In addition to the instructions in this instruction manual, the general safety and accident prevention regulations must be observed.



This signal stands at points in this instruction manual of particular importance for compliance with regulations and directives, for correct workflow and for the prevention of damage to and destruction of the pump or its subassemblies.

0.3. Qualification and training of personnel



The personnel in charge of installation, operation and maintenance of the pumps we produce must be qualified to carry out the operations described in this manual. Tapflo shall not be held responsible for the training level of personnel and for the fact that they are not fully aware of the contents of this manual. In case any instructions in this manual are unclear or any information is lacking, please contact Tapflo before handling the pump.

1. INSTALLATION

1. INSTALLATION

1.1. Operation principle

Double Piston-Diaphragm Pump

The FP/FH pump series FP is a double acting piston-diaphragm pump with a hose as the diaphragm. This hose is compressed by a hydraulic liquid which also restores its original shape. While the hose is compressed, the slurry inside is displaced and flows out. Ball valves on the top and bottom of the hose ensure that the flow is in one direction only.

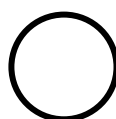
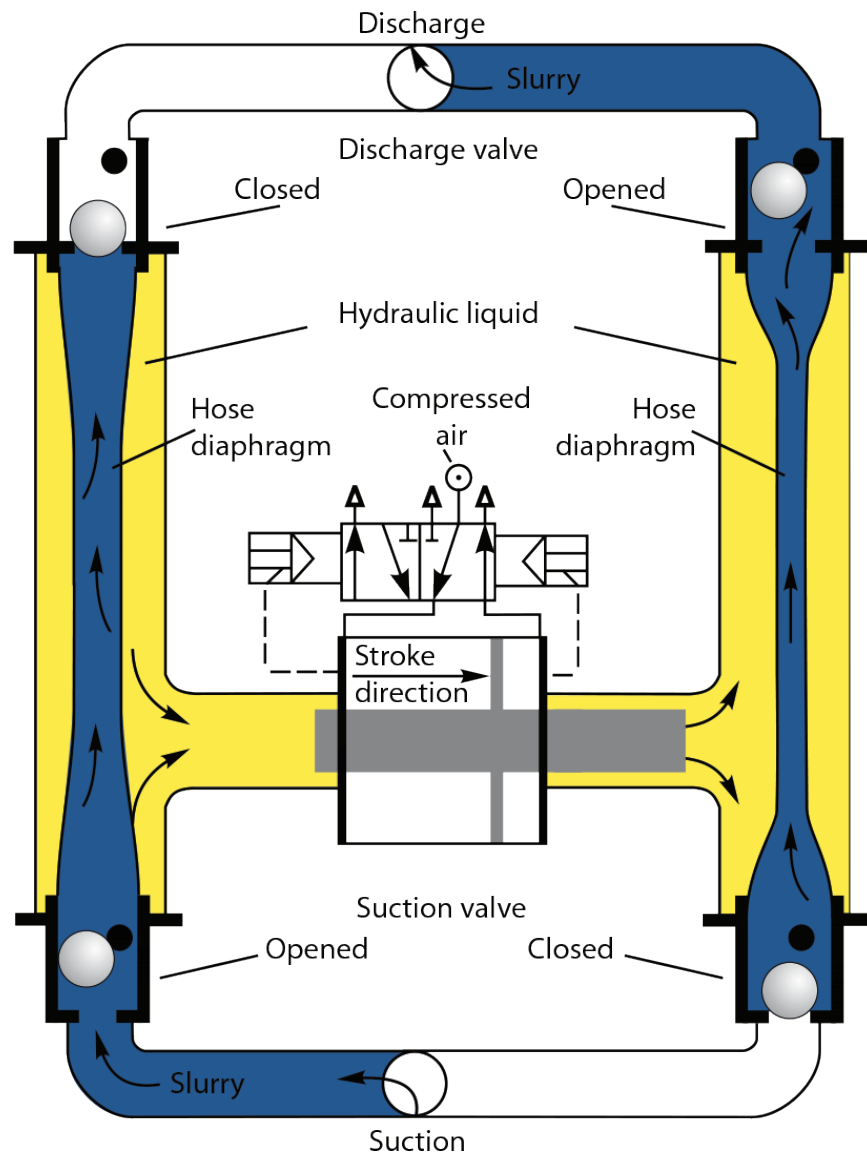

a: open



b: compressed

The two extreme deformation conditions of the hose

1. INSTALLATION

The hose only has to separate the hydraulic liquid from the slurry and is pressure neutral. The pressure inside and outside the hose is always the same. This is why the diaphragm has an extremely long service life besides the fact that it is never compressed totally. It only flexes in the elastic range of the material.

Pneumatic Drive

Compressed air is moving the pneumatic piston which is attached to the hydraulic piston. The hydraulic piston is moving the hydraulic liquid which is acting on the diaphragm hose. Pressure transmission ratio is created by the difference in surface area size between pneumatic and hydraulic pistons. The endpoint in the movement of the air piston is registered by two electronic sensors without any mechanical contact. The signal of these switches controls an electric 5/2 solenoid valve which leads the air to the opposite side of the piston.

Self-Regulating

The pneumatic drive system of the pump results in a continuous balance between the flow rate of the pump and the quantity of slurry required by the filter press. The pump system thus regulates itself. Even if a valve on the discharge side is closed, the pump simply stops and has no energy consumption. When the valve is opened, the pump starts to operate again. Thanks to this feature, no additional pump control units, such as pressure switches, are required.

Diaphragm failure control

Damage to the hose can be detected by an optional sensor unit. Once sensor will detect diaphragm fracture, alarm will appear. In this case service must be carried out immediately. Please note that even if the hose is damaged, the pump will continue to work as a simple piston pump.

1.2. Receiving inspection

Although precaution is taken by us when packing and shipping, we urge you to carefully check the shipment on receipt. Make sure that all parts and accessories listed on the packing list are accounted for. Immediately report any damage or shortage to the transport company and to us.

1.3. Lifting and transportation

Before handling the pump check the weight of the pump (see 5.4. *Technical data*). Refer to Your local standards on how to handle the pump. If the weight is excessive to transport by hand it must be lifted using slings and a suitable lifting device e.g. a crane or forklift.

Always use at least two slings and make sure they are secured in such a way to prevent the pump from slipping and that the pump unit is hanging straight.

Never lift the pump with only one sling. Incorrect lifting can cause serious injury and/or damage to the pump.

1. INSTALLATION

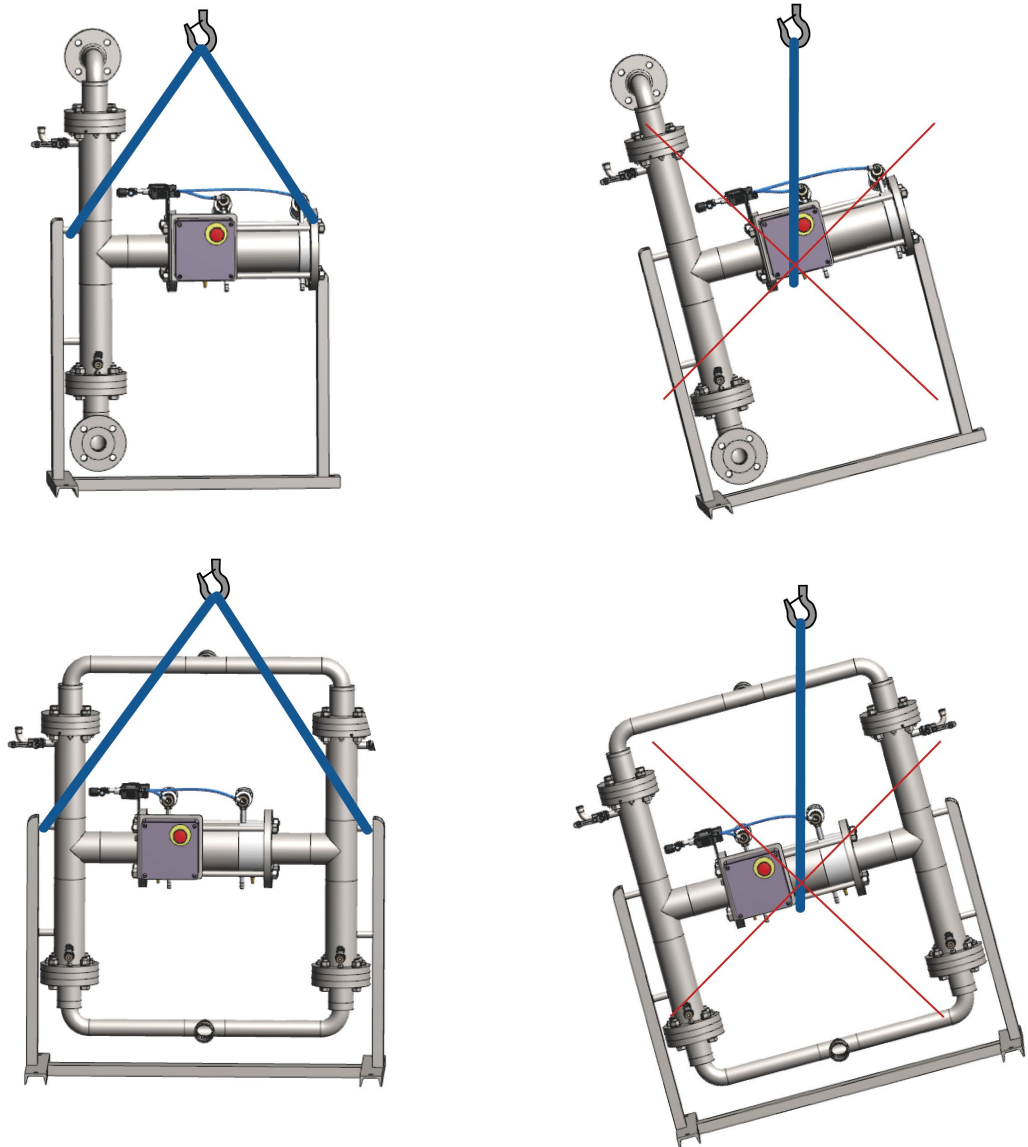

Never lift the pump under pressure.
Be careful that nobody passes under the pump when lifted.
Never try to lift the pump by the hoses attached to the pump.
As an option pumps can be equipped with lifting eyebolts connected with the pump housing.

1.4. Storage



If the equipment is to be stored prior to installation, place it in a clean location. The pump should be stored in an ambient temperature of 15°C (59°F) to 25°C (77°F) and relative humidity below 65%. It should not be exposed to any heat source e.g. radiator, sun as this could result in a negative way on the tightness of the pump. Do not remove the protective covers from the suction, discharge and air connections which have been fastened to keep pump internals free of debris. Clean the pump thoroughly before installation.

1. INSTALLATION

1.5. Foundation



The pump is furnished with vibration absorbing base frame. The pump will operate properly without additional shock absorbers. Make sure the foundation is able to absorb vibrations and fix the base frame with screws to the foundation. It is essential for the operation of the pump to mount the pump vertical. (see sketch in chapter 1.10 "Recommended installations").

1.6. Suction and discharge piping

Suction and discharge piping should be fully supported and anchored near to but independent of the pump. The piping to the pump should be connected with rubber compensator, to prevent undue stress and strain on the pump connections and the piping.

1.6.1. Connection of suction pipe

Remember that the suction pipe/connection is the most critical point, especially if the pump is priming. Just a small leakage will dramatically reduce the suction capability of the pump. When connecting the suction pipe, following is recommended.

- 1) For satisfactory operation, use reinforced hose (the suction power may otherwise shrink the hose) or other flexible piping. The internal diameter of the hose should be the same as on the suction connection (at the bottom of the pump) to have best suction capability.
- 2) Make sure that the connection hose - pump is completely tight, otherwise the suction capability will be reduced.
- 3) Always use as short suction pipe as possible. Avoid air pockets which can arise with long piping.

1.6.2. Connection of discharge pipe

For this connection it is only recommended a simple and positive flow connection. Use rubber compensator between the discharge connection and any rigid fixed piping. All components (hose, pipe, valves etc.) on the discharge piping must be designed for minimum PN 16 for FP pumps and pumps with PP manifold, PN 25 for FH pumps.

1.7. Health and safety

The pump must be installed according to local and national safety rules.



The pumps are constructed for particular applications. Do not use the pump on applications different from that for which it was sold without consulting us to ascertain its suitability.

1.7.1. Protection



In the interest of health and safety it is essential to wear protective clothing and safety goggles when operating, and/or working in the vicinity of Tapflo pumps.

1. INSTALLATION

1.7.2. Air pressure

The maximum air pressure for FP/FH series pumps is 7 bar. Higher air pressure than 7 bar can damage the pump and may cause injury to personnel in vicinity of the pump. If you intend to apply a higher air pressure than 7 bar, please consult us.

1.7.3. Noise level



At tests, the noise level from a FP/FH pump has not exceeded 80 dB(A). Under some circumstances, for example if the pump is operating under high air pressure at low discharge head, the noise can be inconvenient or hazardous for personnel staying for long periods in the vicinity of the pump. This hazard can be prevented by:

- using suitable ear protection;
- lowering the air pressure and/or raising the discharge head;
- leading out the outgoing air from the room by connecting a hose to the muffler connection of the pump;

1.7.4. Temperature hazards

- Raised temperature can cause damage on the pump and/or piping and may also be hazardous for personnel in the vicinity of the pump/piping. Avoid quick temperature changes and do not exceed the maximum temperature specified when the pump was ordered. See also general max temperatures based on water in chapter 5. "DATA".



- When the pump is exposed to ambient temperature variations or if there is big difference between the temperature of the product and the surrounding, the tightening torques of the housing nuts should be checked periodically as part of preventive maintenance. **Please contact Tapflo for tightening intervals recommendation.**

- Below 0°C (32°F) plastic materials become more fragile what can cause accelerated wear of parts made of these materials. This is a hazard that has to be accepted when pumping such cold products. Also, in such case, when a pump is not operational it should be drained of all liquid.



- Bear in mind that the viscosity of the product changes with temperature. This has to be taken into consideration when selecting the pump.

1.8. Air connection

Screw the air hose into the air intake of the pump with for example a bayonet coupling. For best efficiency, use the same hose diameter as the internal diameter of the connection on the air intake.

1.8.1. Air treatment system



Maximum air pressure is 7 bar. As prevention purpose, a filtration of the air by means of a 5-micron filter or finer is recommended. Recommended air quality according to PN-ISO8573-1:2010 is particles class 7, water class 4 and oil class 4. Dirt in the air can under unfortunate circumstances be the cause of a breakdown. The air valve is constructed for oil free air. Lubrication of the air increases the lifetime of the pneumatic parts. But when the air once is lubricated, the lubrication never may be interrupted. For more details please contact your Tapflo representative.

1. INSTALLATION

To facilitate the operation of the pump we recommend an air treatment system connected to the air supply. These components should be included:

- 1) Regulator to adjust the air pressure;
- 2) Manometer to read the actual pressure;
- 3) Needle valve to adjust the air flow (especially when operating the pump in the lower range of performance);
- 4) Filter.

These components are included in Tapflo's **Air treatment system** which can be ordered from us.

1.8.2. Air quality classes

ISO 8573-1:2010 Compressed Air Contaminants and Purity Classes

Class	Solid particles			Mass concentration [mg/m ³]	Water		Oil
	Maximum number of particles per m ³	Pressure dew point [°C]	Liquid [g/m ³]		Total oil content (liquid, aerosol and vapour) [mg/m ³]		
	0.1 – 0.5 µm	0.5 – 1 µm	1 – 5 µm				
0	As specified by the equipment user or supplier and more stringent than class 1						
1	≤ 20,000	≤ 400	≤ 10	-	≤ -70	-	0.01
2	≤ 400,000	≤ 6,000	≤ 100	-	≤ -40	-	0.1
3	-	≤ 90,000	≤ 1,000	-	≤ -20	-	1
4	-	-	≤ 10,000	-	≤ +3	-	5
5	-	-	≤ 100,000	-	≤ +7	-	-
6	-	-	-	≤ 5	≤ +10	-	-
7	-	-	-	5 – 10	-	≤ 0.5	-
8	-	-	-	-	-	0.5 – 5	-
9	-	-	-	-	-	5 – 10	-
X	-	-	-	> 10	-	> 10	> 10

1. INSTALLATION

1.9. Installation example

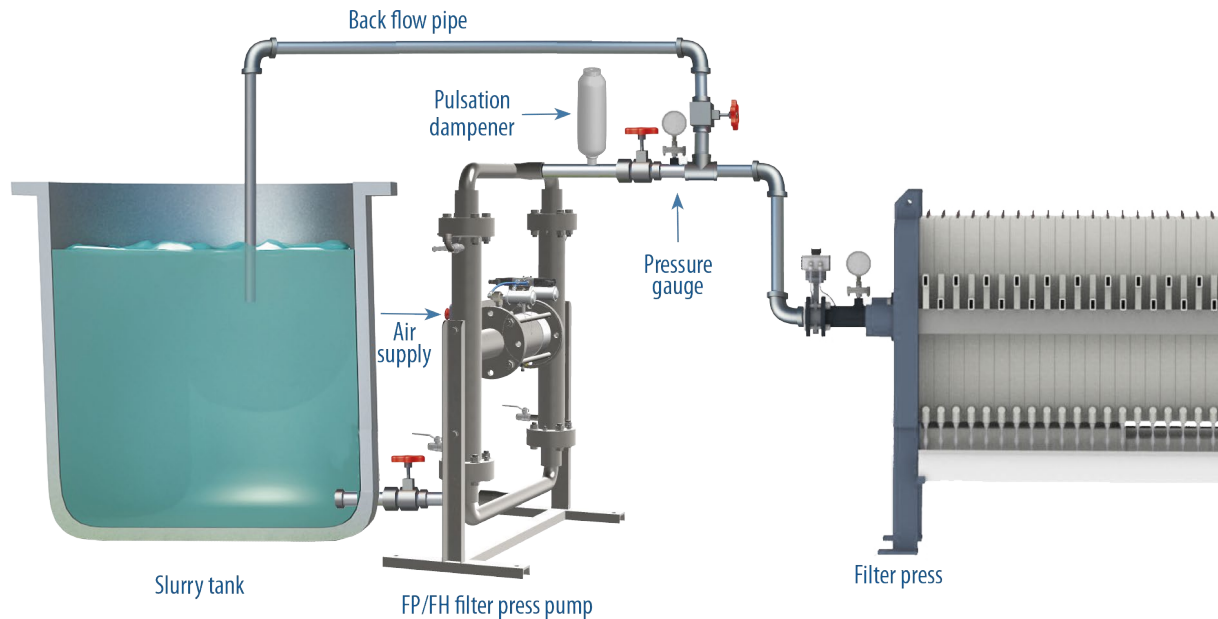

1.10. Recommended installations

The FP/FH pump is flexible in the way you are able to install it.

1.10.1. Flooded



The piping system is designed with a positive suction head. This is the best way of installation where it is necessary to completely evacuate all liquid from the container, or where viscous (thick) products are transferred.

1.10.2. Self-priming

The FP/FH pump is designed to pull a vacuum. It is able to evacuate an empty suction pipe without any damage to the pump. The suction lift is up to 2 meters (6.6 ft.) from an empty suction pipe and up to 5 meters (16.4 ft.) from a wetted pipe. The suction capability depends on the pump size (see chapter 5. "Data").



NOTE!

Even if all above safety instructions are met and complied with, there still exists a minor danger in the event of a leakage or mechanical damage of the pump. In such case the pumped product can emerge on sealing areas and connections.

1.11. Electric Connection

The pump needs a power supply for the operation of the solenoid valve. Please keep care, that the installation is done properly according to the national standards. Tight the cable fittings to avoid the ingress of water. All internal cable wiring is done.

1. INSTALLATION

1.11.1. 24 V DC (Standard)

The power supply is connected to the clamps inside the control box, marked with + and -. Keep care for the right poles. The power consumption is 12 W.

1.11.2. 230 V AC

The power supply is connected to the clamps inside the control box, marked with L, N, and PE (ground connection). Keep care, that the ground connection is installed properly.

1.11.3. Connection diagram

1.11.3.1. 24V DC power supply - Standard

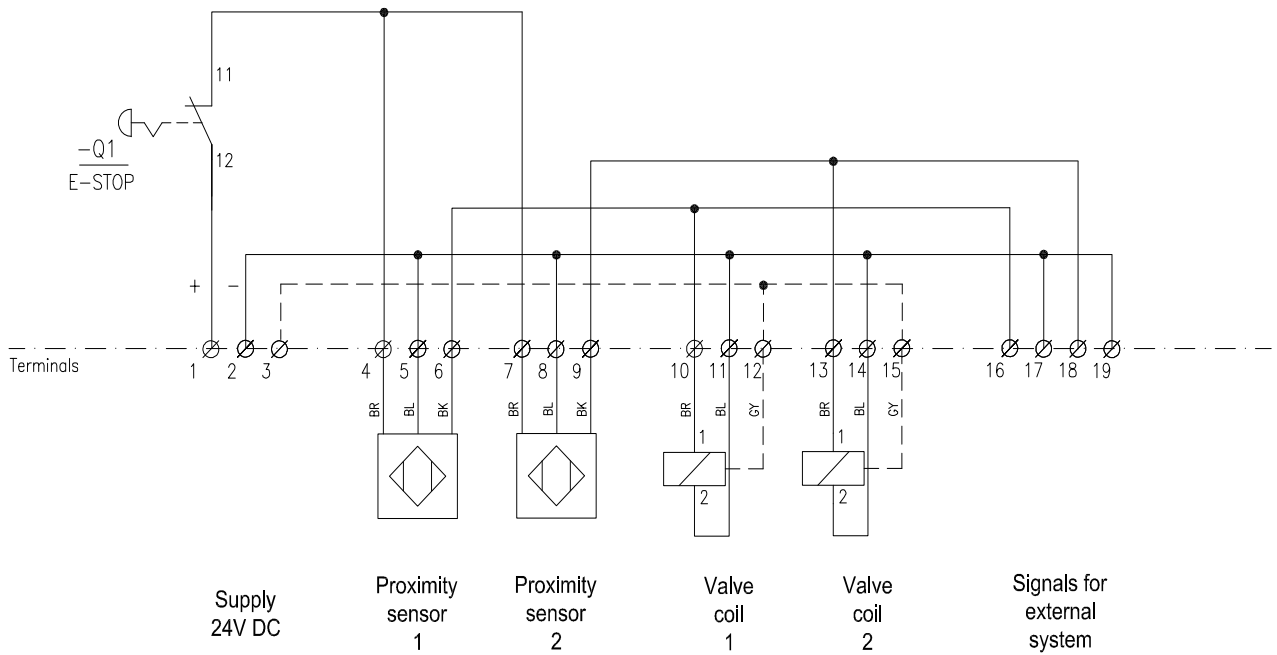

1. INSTALLATION

1.11.3.2. 230V AC power supply

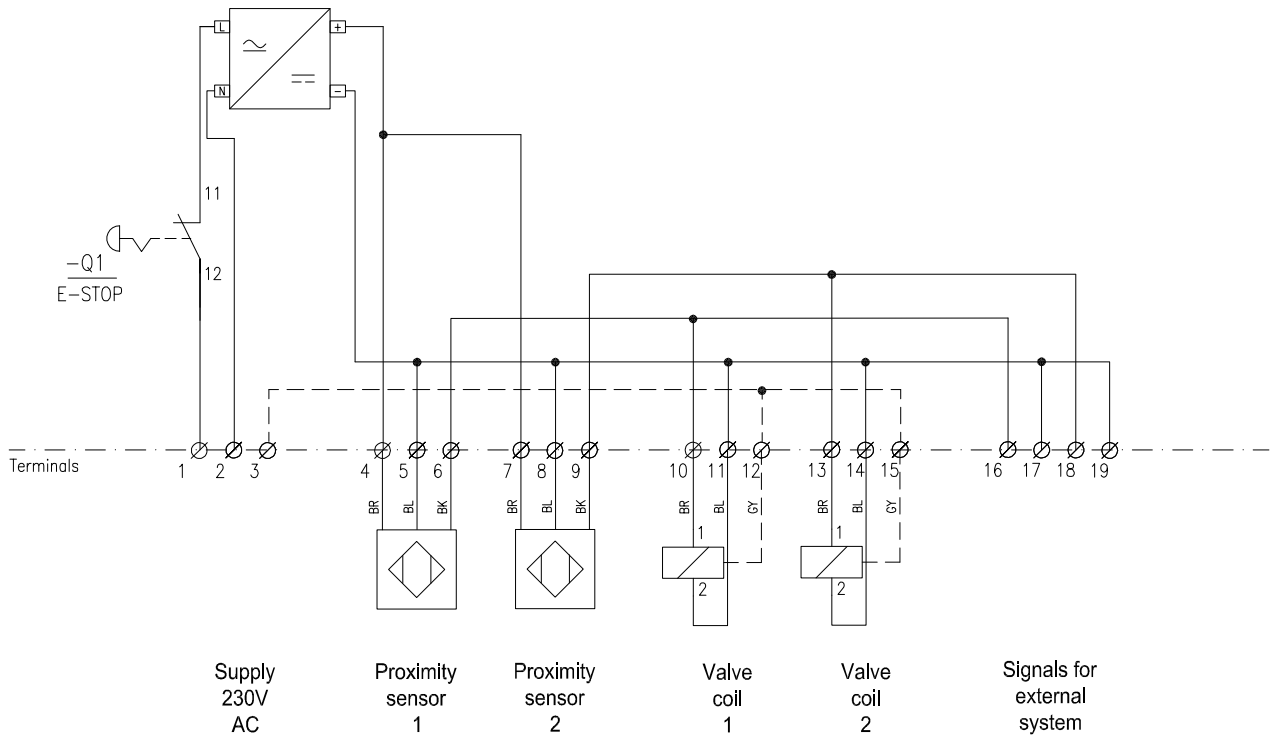

1.11.3.3. 24V DC power supply with diaphragm control unit

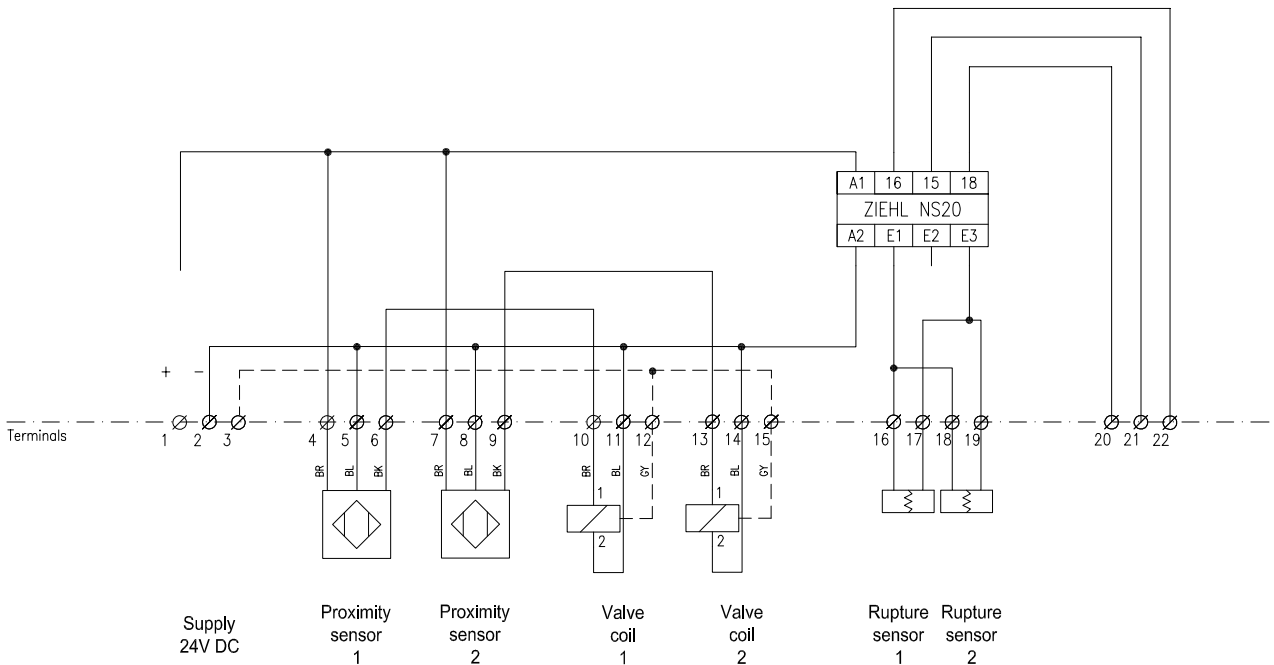

1. INSTALLATION

1.11.3.4. 230V AC power supply with diaphragm control unit

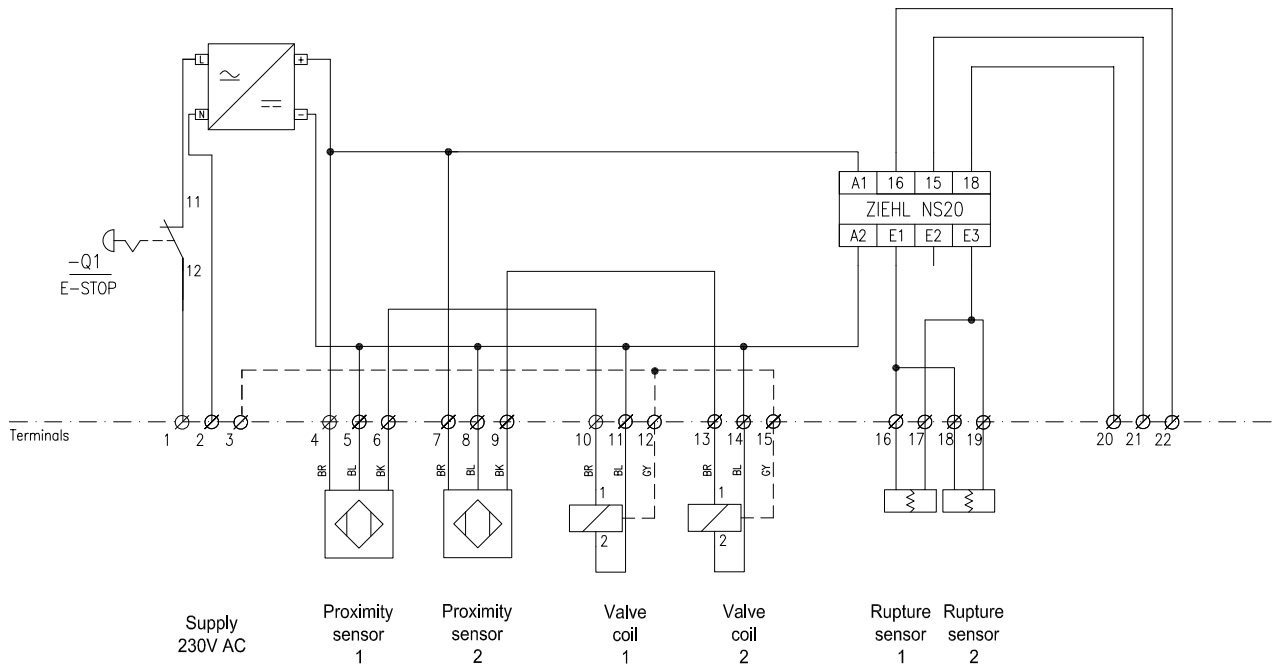

1.12. Diaphragm control unit for FP/FH Pumps Series

The diaphragm control unit is designed to detect an early break of the diaphragm in the FP/FH pumps series. Only a small hole in the diaphragm will cause a mixing of slurry with hydraulic liquid and so a damage of the hydraulic parts in the pump. A break of the diaphragm can't be recognised, because the pump works as a simple piston pump even without a diaphragm. The hydraulic liquids we use are not electrically conductive, but the slurries have a high conductivity. These different characteristics are used to detect the contamination of the hydraulic liquid by a slurry. Between the two electrodes of the sensor an electric current of 8V is connected. When a conductive liquid allows the flow of the power, the electronic device will recognise and switch a relay. With the potential free contacts of this relay an alarm signal can be connected or the pump can be switched off.

1.12.1. Installation of the sensors

The sensors are screwed in the draining valves on the bottom of the hydraulic chambers. For the sealing a tape of Teflon. The pump sizes 25 need only one sensor, all others need two sensors.

1.12.2. Procedure of adjustment

Closing the drain valve and screwing off the plug. Screw in the sensor instead of the plug and open the drain valve. For testing the function of the unit, the sensor can be dipped into the slurry. When all parts are connected well, the electronic must switch in this case. If no function is to recognise, first the wiring has to be checked. When the wiring seems to be correct, the adjustment screw on the electronic has to be turned clockwise, till the relay switches. After taking the sensor out of the slurry, the relay must go back to neutral position again. If not, clean the surface of the sensor. This can be done while power is switched on.

1. INSTALLATION

1.12.3. Control unit signals

- LED green:
Operation, on as soon as power supply is on
- LED yellow:
On when no signal is given (no diaphragm break)
Off as soon as current flows from 16/18 to 17/19 - (diaphragm break)
- Signals (terminal contacts short circuited):
No Power: 21 - 22
No Alarm, LED green: 20 - 21
Alarm, LED green off: 21 - 22

2. OPERATION

2. OPERATION

2.1. Before starting the pump



- Make sure the pump is installed according to the installation instruction (chapter 1).
- Filling of the pump with liquid before start is not necessary. Only at high suction lift it may help to fill the pump with water on the suction side to increase the suction capability.



- When installation is new or reinstalled, a test run of the pump with water should be conducted to make sure that the pump operates normally and does not leak.

2.2. Starting and operation

- Open the discharge valve.
- Pull out the red button on the control box to switch the control power.
- **Note! Considering the suction capacity when air is still in the suction pipe, it is recommended to start with low air pressure/flow (slowly) at the beginning. This is not necessary if the pump is filled with liquid before start.**
- When the pump has been filled with liquid, the air pressure/flow may be raised in order to increase the suction capacity of the pump.
- Below maximum allowable stroke frequency for cycles. Please run the pump with the lowest possible speed. Stroke - One move of single diaphragm. Two strokes per cycle.
 - FP25: 60 1/min
 - FP40: 83 1/min
 - FP50: 58 1/min
 - FP80: 75 1/min
- The performance of the pump can be adjusted through the air supply by using a needle valve and a pressure regulator. The performance can also be adjusted by normal flow control on the discharge side of the system.

2.2.1. Dry running

Although the pump is prepared for dry running it is important to have in mind that long periods of dry run may increase the wear. Also, an empty pump should operate at low speeds – controlled by a needle-valve.

2.2.2. Optimization of the pump lifetime



- Running at full frequency (maximum air pressure/flow) continuously will cause premature wear of the components.
- As stated in chapter 1.8.1 Tapflo recommends using an appropriate air treatment system in order to extend the pump's lifetime.
- If the air humidity is high, use of a water separator or air dryer is recommended. Otherwise on the air discharge side due to decompression, icing on the muffler can appear causing it to shrink and eventually it can shoot out of its socket.

2. OPERATION

- If the ambient air is humid, icing can occur outside of the muffler. In such case it is recommended to use a longer exhaust of the compressed air (ca. 500 mm / 19,7").
- Operate the pump as slow as possible.

2.3. Pump stopping

The pump can be stopped in three ways:

- 1) Close the discharge valve. The pressure from the system will stop the pump automatically. This will not do any damage to the pump. The pump restarts easy when the valve is opened again.
- 2) By cutting off the air supply.
- 3) Switch off control panel

2.4. Residual risks

Even with proper application and observance of all points listed in this operating manual, there is still an estimable and unexpected residual risk when using the pumps. It may leak, fail due to wear, application-related causes or system-related circumstances.

2.5. Disposal after expiration of the expected lifetime

The metallic components like aluminium, stainless steel and carbon steel can be recycled. Plastic parts are not recyclable and must be disposed of as residual waste. The pump must be disposed of properly, according to local regulations. It should be noted that potentially dangerous fluid residues may remain in the pump and can create a hazard to the operator or the environment, therefore the pump has to thoroughly cleaned before disposal. The hydraulic liquid is biodegradable; however, it must be recycled according to national regulations.

2.6. Waste of electrical and electronic equipment (WEEE) directive

Users of electrical and electronic equipment (EEE) with the WEEE marking per Annex IV of the WEEE Directive must not dispose of end of life EEE as unsorted municipal waste, but use the collection framework available to them for the return, recycle, recovery of WEEE and minimize any potential effects of EEE on the environment and human health due to the presence of hazardous substances. The WEEE marking applies only to countries within the European Union (EU) and Norway. Appliances are labelled in accordance with European Directive 2002/96/EC. Contact your local waste recovery agency for a designated collection facility in your area.

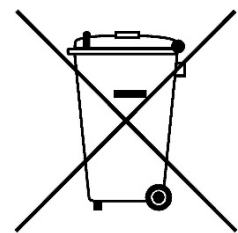

2.7. Actions in emergency

In case of a leakage of an unknown fluid, respiratory protection should be worn and contact with the fluid avoided. During firefighting, keep in mind that hydraulic part of pump is filled with oil and control unit is connected to electricity. In addition, the currently

2. OPERATION

handled fluid and the corresponding safety data sheet must be taken into account. In the event of personal injury, the appropriate emergency number or 112 must be chosen.

3. MAINTENANCE

3. MAINTENANCE

3.1. When the pump is new or reassembled



If the pump is new or reassembled after maintenance, it is important to retighten the pump manifolds screws (pos. 38) after approximately one week of operation. Make sure to use the right torque – see chapter 5.5 *"Tightening torques"*.

3.1.1. Performance test

When installation is new, a test run of the pump should be conducted. Gauge the capacity at specific air pressure/flow. This information is useful for checking performance in the future as wear takes place. You will be able to set schedules for maintenance of the pump and to select spare parts to be kept on stock.

3.2. Routine inspection



Frequent observation of the pump operation is recommended to detect problems. A change in sound of the running pump can be an indication of wearing parts (see chapter 3.5 *"Location of faults"* below).

Leaking liquid from the pump and changes of performance may also be detected. Routine inspections should be conducted frequently.

The installation of pressure gauges in the filling nozzles of the hydraulic allows the observation of function of the hydraulic. When pressure gauges with a range of -1 to +15bar are used, the suction lift also can be inspected.

Please isolate gauge glasses by closing ball valve when you don't observe them.

3.3. Complete inspection



The intervals for a complete inspection depend upon the operation conditions of the pump. The characteristics of the liquid, temperature, materials used in the pump and running time decide how often a complete inspection is necessary.

If a problem has occurred, or if the pump is in need of a complete inspection, refer to chapters 3.5 *"Location of faults"* and 3.6, 3.7 *"Dismantling of the pump"*. You are of course warmly welcome to consult us for further help.

Parts that are subject to wear should be kept in stock, see our recommendations in chapter 4.7 *"Stocking recommendation"*.

3. MAINTENANCE

3.4. Location of faults

PROBLEM	POSSIBLE FAULT	POSSIBLE SOLUTION
The pump does not run	No control power Too much hydraulic liquid (one pressure gauge at housing indicates pressure) The air pressure is too low The air connection is blocked	Switch red button at the control box, check polarity Drain hydraulic liquid to adjust the diaphragm Increase air pressure via a filter-regulator Check / clean air supply connection
The suction is bad	Muffler is blocked Suction connection is not tight Suction connection is blocked Valve balls are blocked or damaged Valve seats are worn Pump starts with high pressure Air in suction / discharge line Dry suction against discharge pressure	Check / clean / replace muffler Tighten the suction line Clean suction line Check dimensions and shape of valve balls Check dimensions and shape of valve seats Start the pump slowly (see chapter 2.2) Vent suction / discharge line Wet the pump / start without discharge pressure
The pump runs irregular	Valve balls are blocked Diaphragm breakdown Valve seats are worn Icing on the muffler	Check dimensions and shape of valve balls Replace diaphragm Check dimensions and shape of valve seats Check dimensions and shape of valve seats Improve air quality (see chapters 1.7.1 and 2.2.2)
Bad flow/pressure	Pressure fall in air supply Pressure losses on suction side Air supply / air valve leaking Suction or air connection blocked Muffler is blocked Valve ball worn or broken Valve seats are worn Air in liquid Diaphragm breakdown Icing on the muffler Air in hydraulic system Air in pipe system Suction pipe untight	Increase air pressure via a filter-regulator Check/change installation on suction side Check / repair / replace air supply / air valve Check / clean air supply / suction connection Check / clean / replace muffler Check dimensions and shape of valve balls Check dimensions and shape of valve seats Seal suction line; check / refill container Check / replace diaphragms Improve air quality (see chapters 1.7.1 and 2.2.2) Remove air Remove air Tighten
Pump leaks oil	Piston speed too high Cavitation in hydraulic system Seal worn out	Reduce air supply Check ball valves Install larger suction pipe Install pulsation dampener on suction side Install filter in air supply Change seal
Pump stops	Failure in control system Pressure on discharge too high No control power	Check control system and change sensors or solenoid valve Increase air pressure Switch on power
Diaphragm breakdown	Wrong selection of material	Contact us for information on material selection
Pump has no flow after service	Pressure from discharge pipe press the balls into the seats	To drain air from the pump use back flow pipe(open the back flow pipe)

3. MAINTENANCE

3.5. FP/FH 25 – Disassembly of the pump

The numbers put in brackets, refer to the part numbers in the spare part drawings and spare part lists in chapter 4 *"Błąd! Wynik nieprawidłowy dla tabeli."*

3.5.1. Before the disassembly procedure



Be sure to drain all liquid from the pump. Cleanse or neutralize the pump thoroughly. Disconnect the air and the power supply and then the suction and discharge connections.

3.5.2. Disassembly procedure

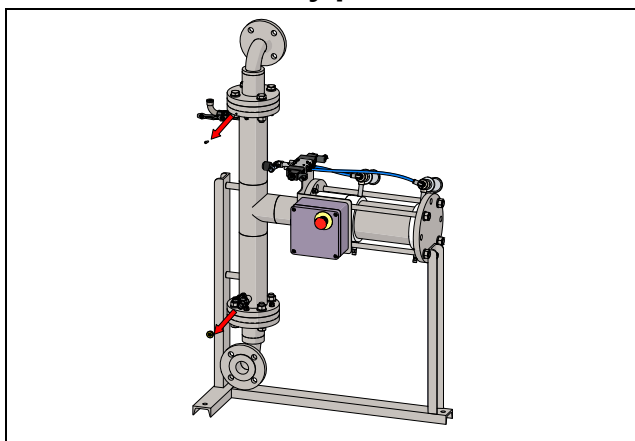

Fig. 3.6.1

Open the drainage ball valve [80] for the hydraulic liquid and collect the liquid. Remove the Ventilation screw [62] for the hydraulic liquid.

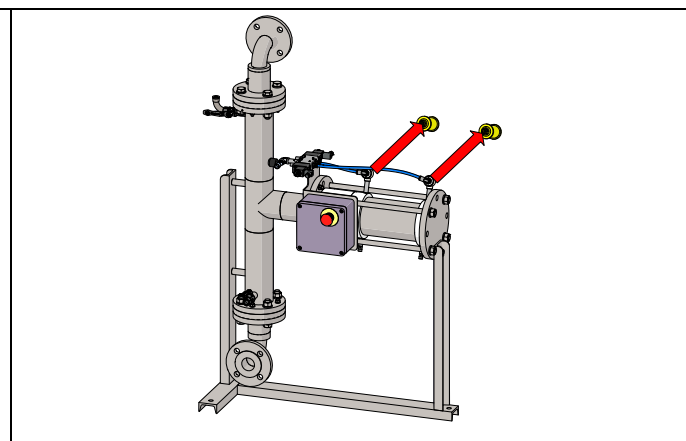

Fig. 3.6.2

Unscrew and remove mufflers [34].

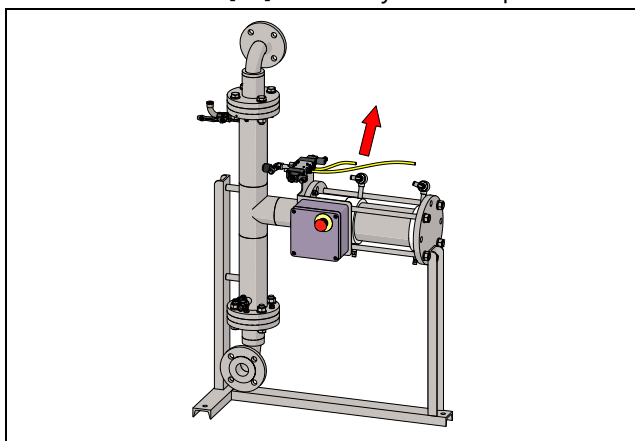

Fig. 3.6.3a

Disconnect two air hoses [33] connecting the outlet manifold [3] to the housings [1].

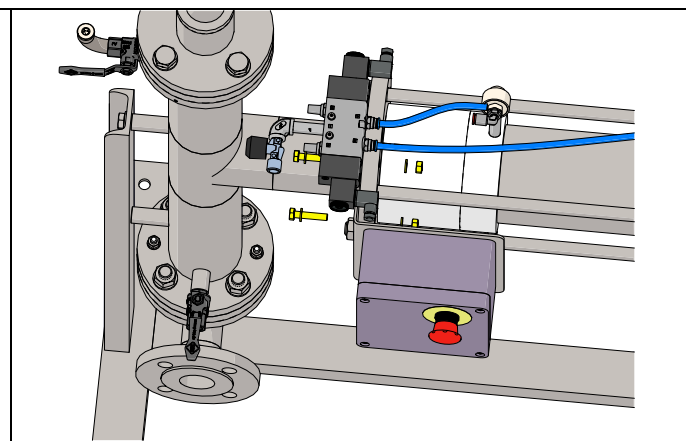

Fig. 3.6.3b

Unscrew and remove two hex screws [61] connecting the control unit [35] to the housings [1].

3. MAINTENANCE

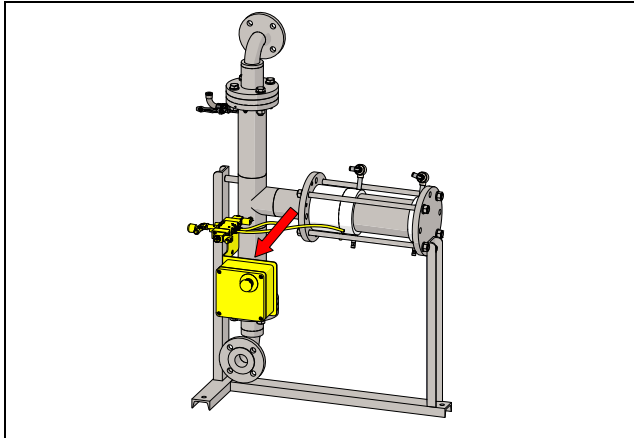

Fig. 3.6.3c
Remove the control unit [35].

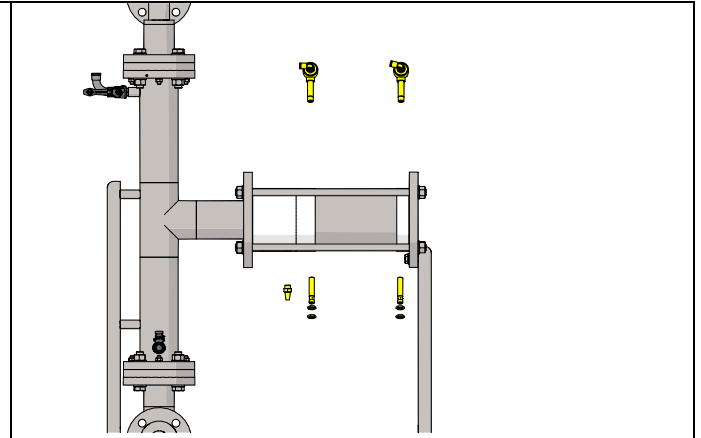

Fig. 3.6.3d
Remove the Quick exhaust valves [32], Sensors [30] and Bronze mufflers [63]. However do not remove sensor if it's not required.

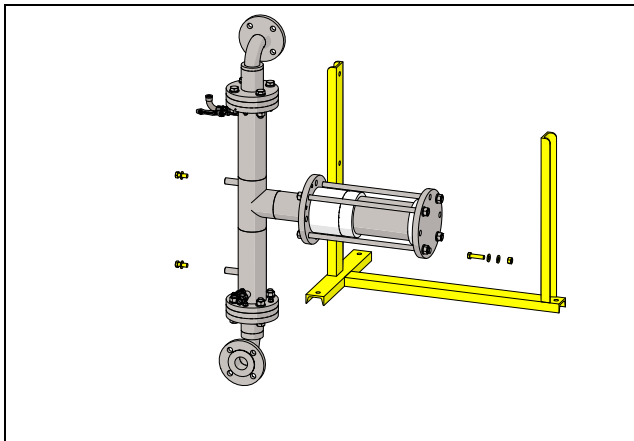

Fig. 3.6.4
Pumps in sizes 25 - 40 are taken out of the base frame and dismantled on a clean table.

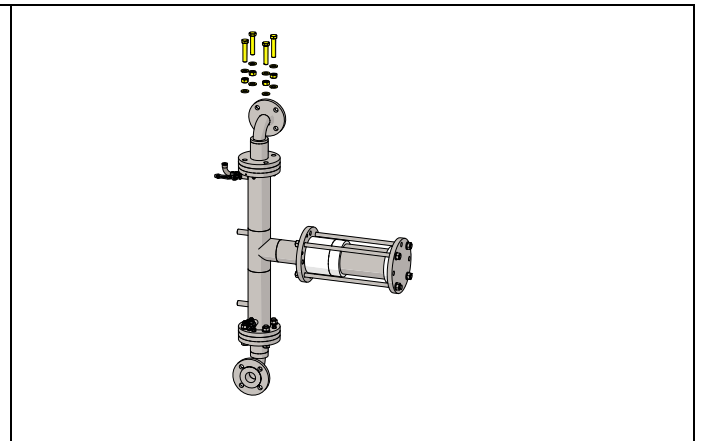

Fig. 3.6.5a
Unscrew and remove eight hex screws [38] connecting the Discharge Manifold [3] to the housings [1].

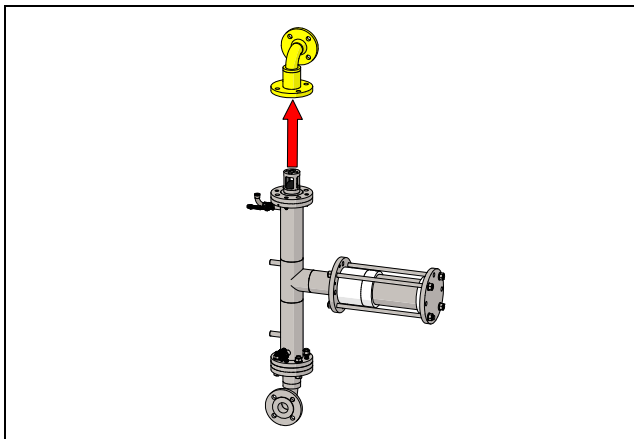

Fig. 3.6.5b
Remove discharge manifold [3] from the housings [1].

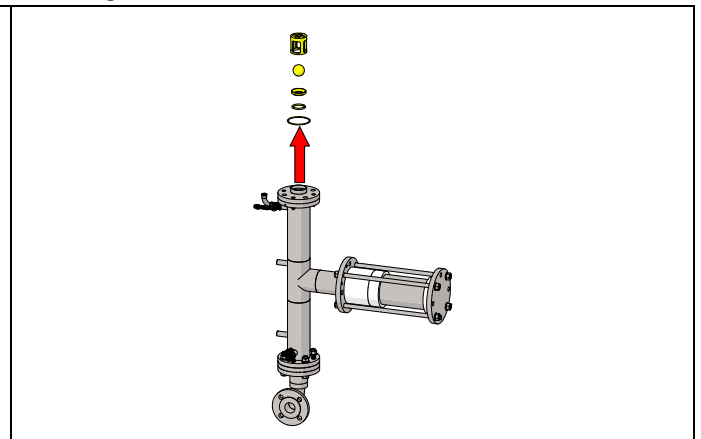

Fig. 3.6.5c
Remove Ball Retainers [11], valve balls [20], Valve Seats [19], O-rings Valve seat [16] and O-rings Flange [24] from the housings [1].

3. MAINTENANCE

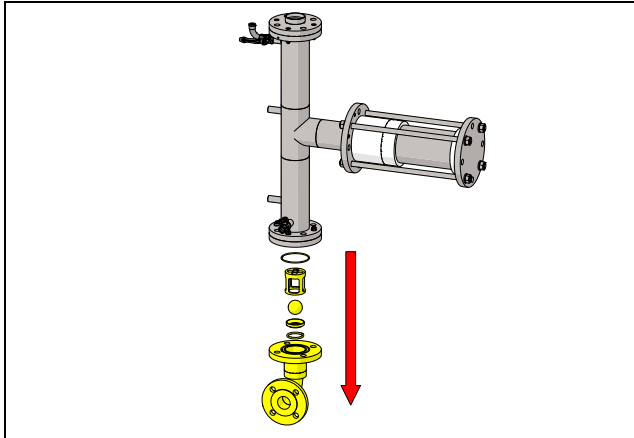

Fig. 3.6.6
Remove eight hex screws with washers and nuts [38], Suction Manifold [2], O-rings valve seat [16], Valve seats [19], valve balls [20], Ball Retainer [71] and O-rings flange [24] by repeating steps 3.6.5 a to c for suction side.

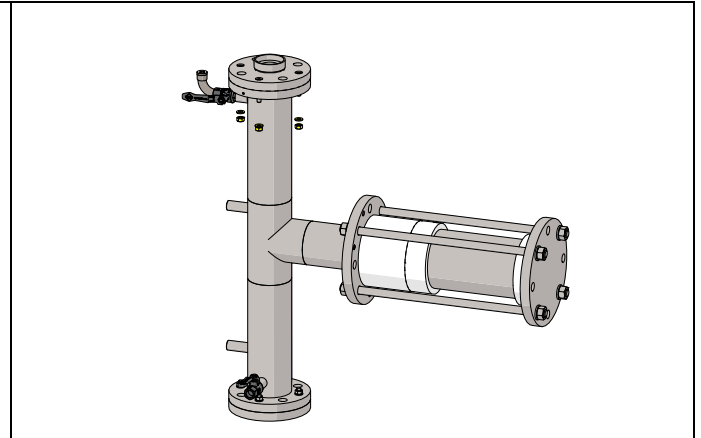

Fig. 3.6.7a
Remove the nuts and washers [42] Medium Flange [15].

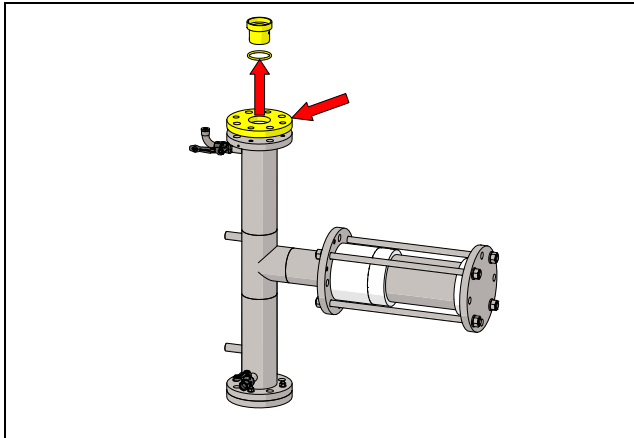

Fig. 3.6.7b
Loose Medium Flange [15] and remove Hose Bush discharge [12] with O-ring Discharge [52].

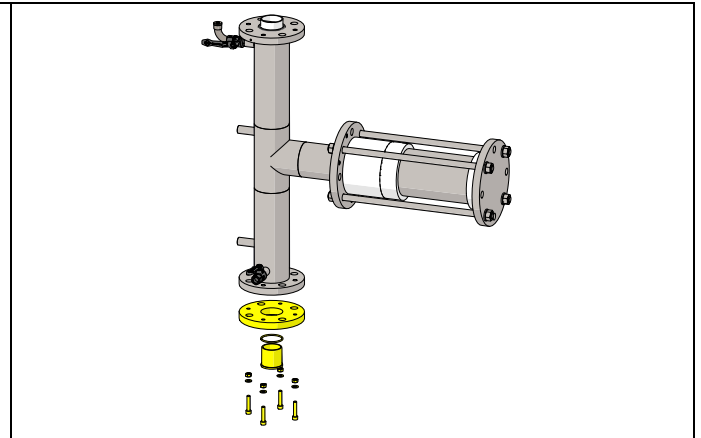

Fig 3.6.8
Repeat steps 3.6.7 a and b to remove remaining screws, Medium Flange [15], Hose Bushes [12] - discharge, [9] - suction and O-rings [52 and 72].

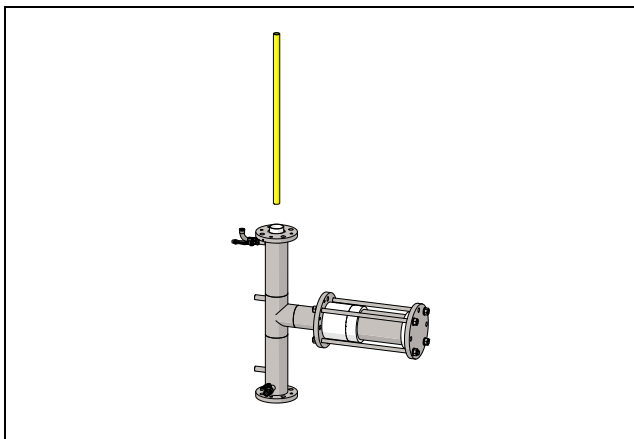

Fig 3.6.9
Remove Balance Tubes [10].

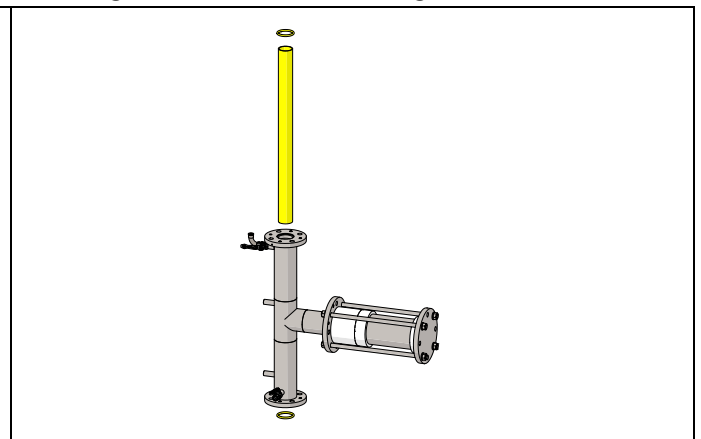

Fig 3.6.10
Remove Diaphragm O-rings [23] and Tubular Diaphragm.

3. MAINTENANCE

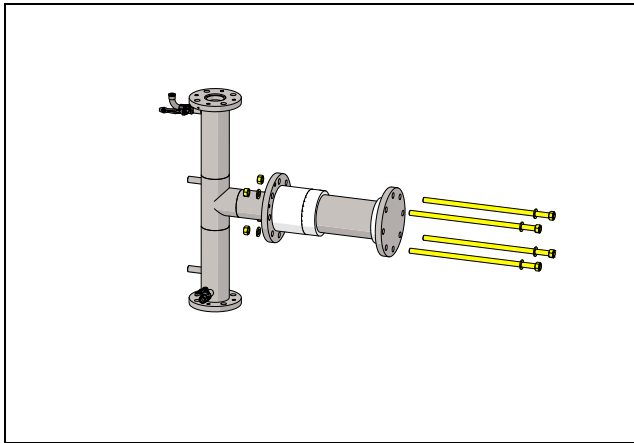

Fig 3.6.11
Remove nuts, washers and Anchor Bolts [8].

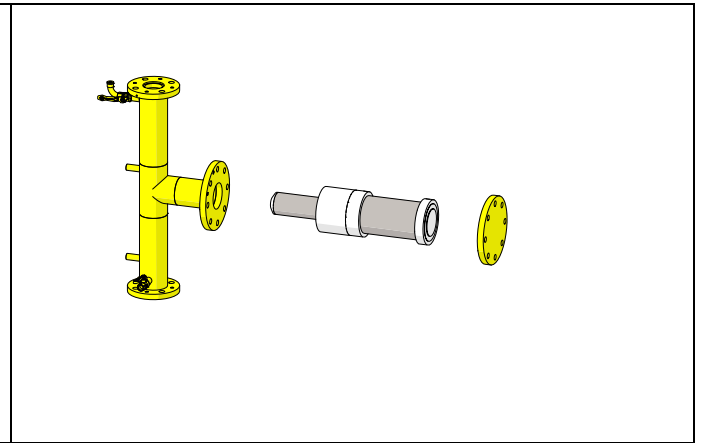

Fig 3.6.12
Disassembly Housing [1] and Blind Flange [13.1] from centre section.

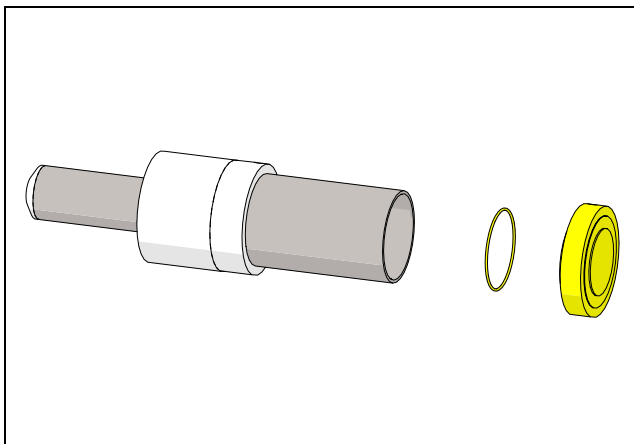

Fig 3.6.13
Remove P-Flange O-ring [51], P-Flange [14], Pneumatic cylinder O-ring [26], Hydraulic Seal [22], and Slide Ring of Hydraulic Piston [28].

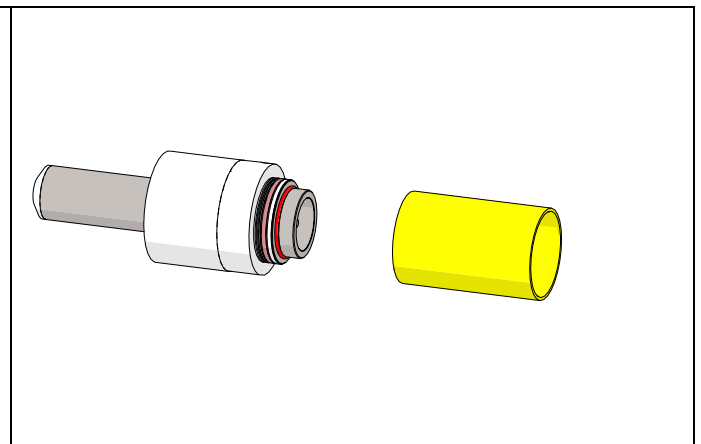

Fig 3.6.14
Disassembly cylinder [4] from piston [6].

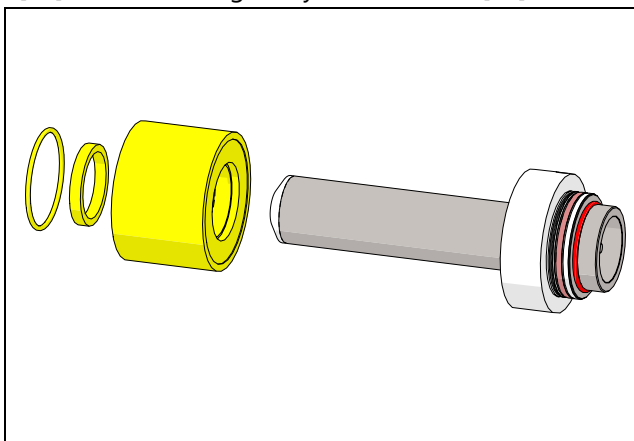

Fig 3.6.15
Disassembly Leading flange [40], Hydraulic Seal Oil side [25] and O-ring [51] from Hydraulic piston [7].

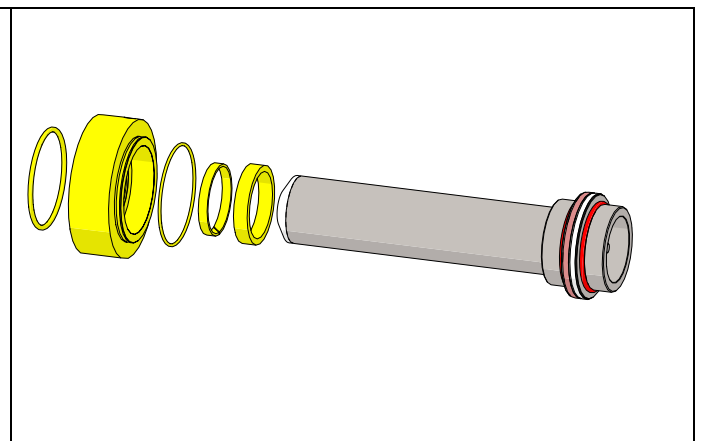

Fig 3.6.16
Disassembly Hydraulic Seal Air side [22], Slide Ring Hydraulic Piston [28], O-Ring Pneumatic Cylinder [26], P-Flange [14] and O-Ring P-Flange [51]

3. MAINTENANCE

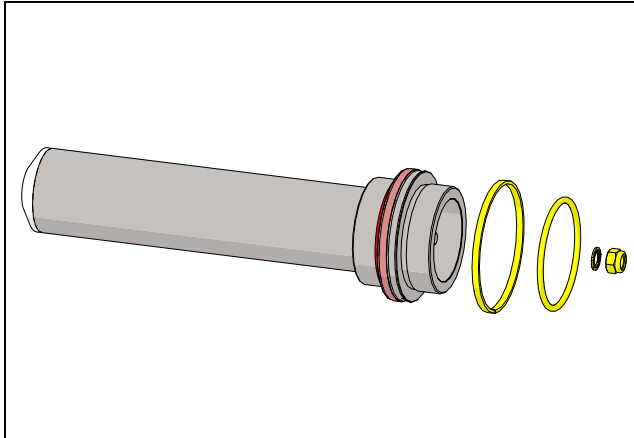

Fig 3.6.17

Disassembly Nut + sealing washer [46], O-Ring Muffling Discharge Stroke [50] and Slide Ring Pneumatic Piston [27].

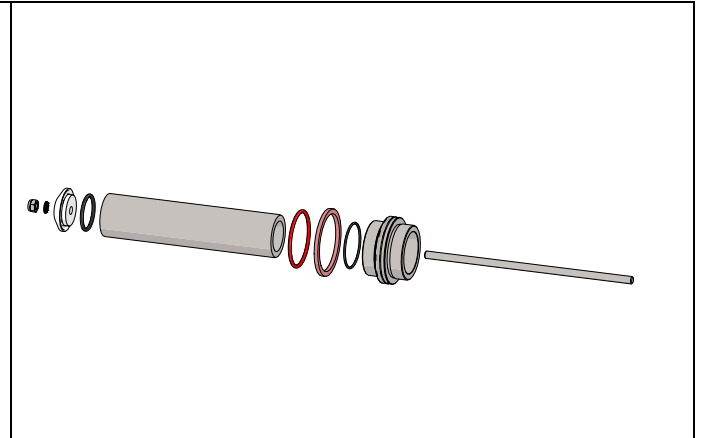

Fig 3.6.18

[46] Nut; Sealing Washer; [17] Piston Cover; [29] O-Ring Piston Cover; [7] Piston Hydraulic; [41] O-Ring Piston Hydraulic; [50] O-Ring Muffling Discharge Stroke; [21] Pneumatic Seal.

The pump is now completely disassembled. Check all components for wear or damage and replace if necessary.

3.5.3. Test run



We recommend you conduct a test run of the pump before installing it in the system, so no liquid gets wasted if the pump leaks or perhaps does not start accordingly to wrong assembly of the pump.

After a few weeks of operation retighten the nuts with appropriate torque.

3. MAINTENANCE

3.6. FP/FH 40-80 – Disassembly of the pump



The numbers put in brackets, refer to the part numbers in the spare part drawings and spare part lists in chapter chapter 4 *"Błąd! Wynik nieprawidłowy dla tabeli."*

3.6.1. Before the disassembly procedure

Be sure to drain all liquid from the pump. Cleanse or neutralize the pump thoroughly. Disconnect the air and the power supply and then the suction and discharge connections.

3.6.2. Disassembly procedure

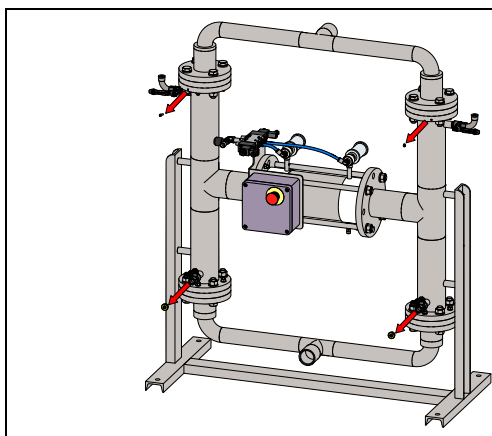

Fig. 3.7.1
Remove the Ventilation screw [62] for the hydraulic liquid. Open the drainage ball valve [80] for the hydraulic liquid and collect the liquid.

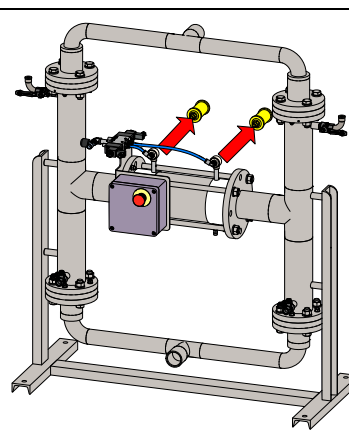

Fig. 3.7.2
Unscrew and remove mufflers [34].

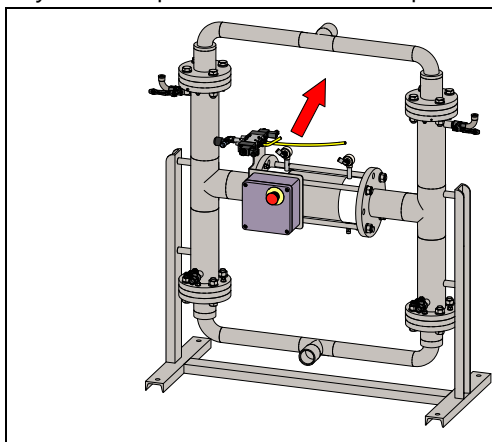

Fig. 3.7.3a
Disconnect two air hoses [33] connecting the outlet manifold [3] to the housings [1].

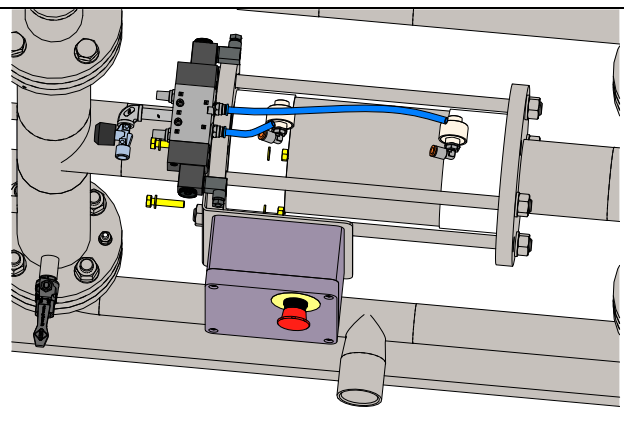

Fig. 3.7.3b
Unscrew and remove two hex screws, nuts and washers [65] connecting the control unit [35] to the housings [1].

3. MAINTENANCE

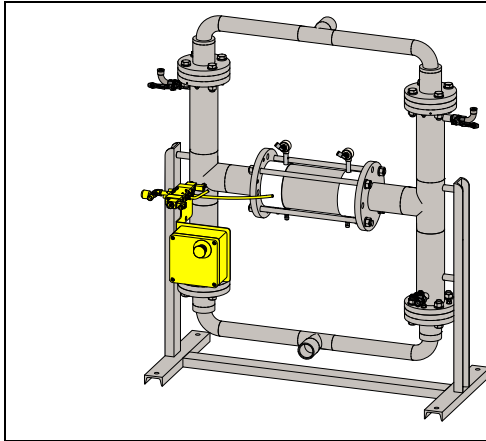

Fig. 3.7.3c
Remove the control unit [35].

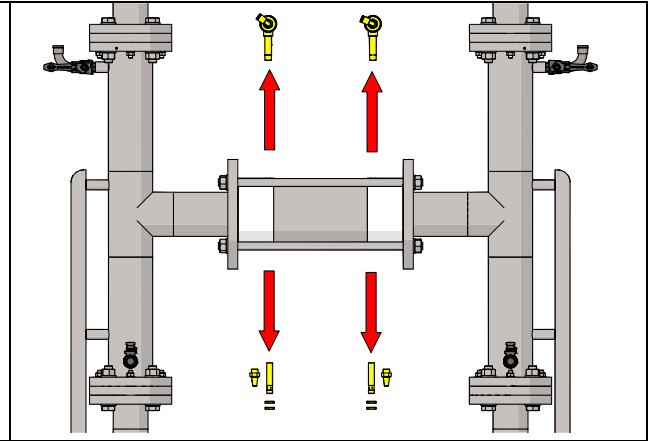

Fig. 3.7.3d
Remove the Quick exhaust valves [32], Sensors [30] and Bronze mufflers [63].

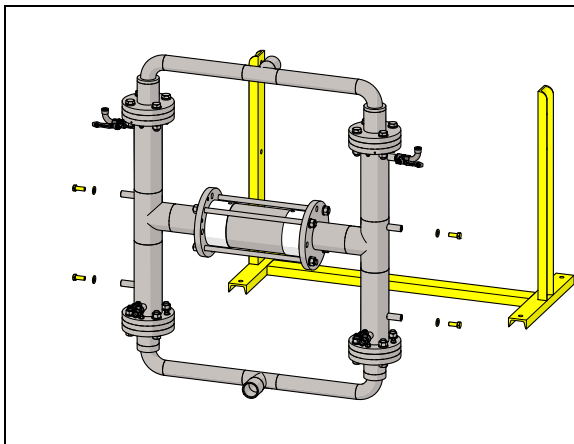

Fig. 3.7.4
Pumps in sizes 25 - 40 are taken out of the base frame and dismantled on a clean table.

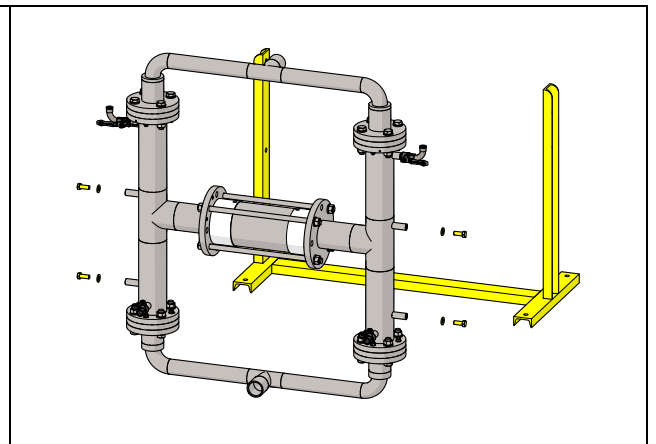

Fig. 3.7.5a
Unscrew and remove eight hex screws [38] connecting the Discharge Manifold [3] to housings [1].

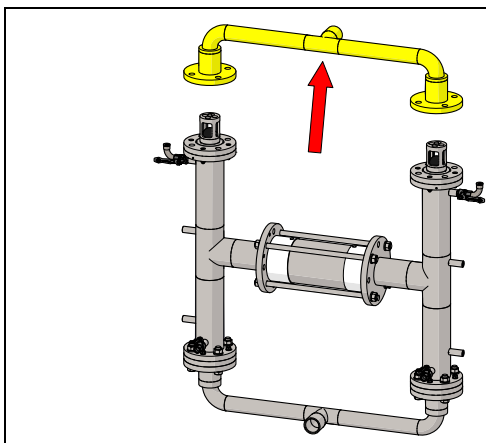

Fig. 3.7.5b
Remove discharge manifold [3] from the housings [1].

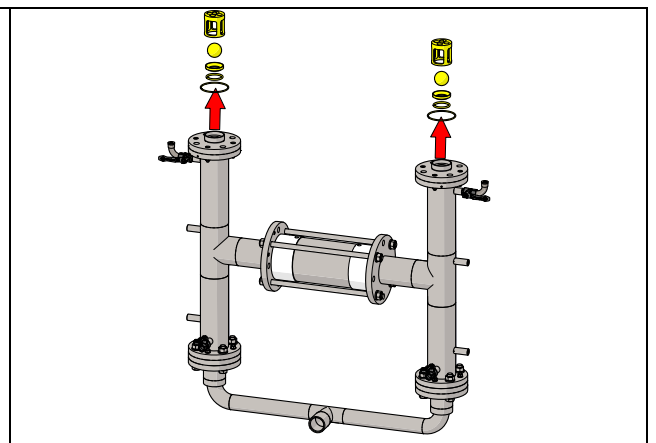

Fig. 3.7.5c
Remove O-rings valve seat [16], Valve seats [19], valve balls [20], Ball Retainer [71] and O-rings flange [24] by repeating steps 3.6.5 a to c for suction side.

3. MAINTENANCE

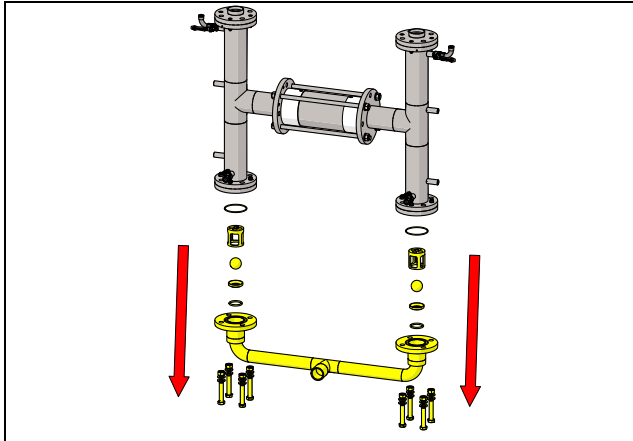

Fig. 3.7.6
Remove eight hex screws with washers and nuts [38], Suction Manifold [2], O-rings valve seat [16], Valve seats [19], valve balls [20], Ball Retainer [71] and O-rings flange [24] by repeating steps 3.5.5 a to c for suction side.

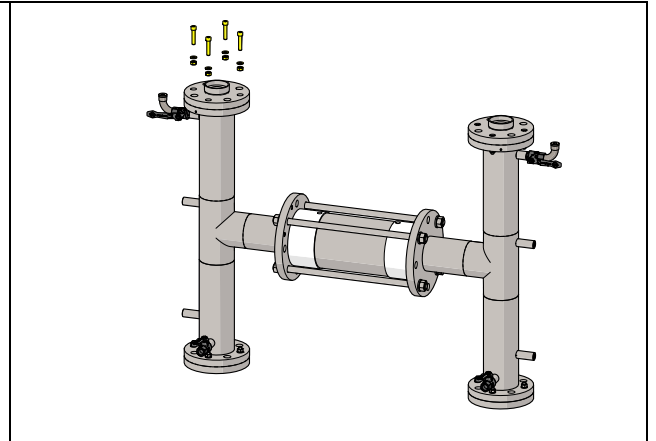

Fig. 3.7.7a
Remove the nuts [42], washers [42] and allen screws [42].

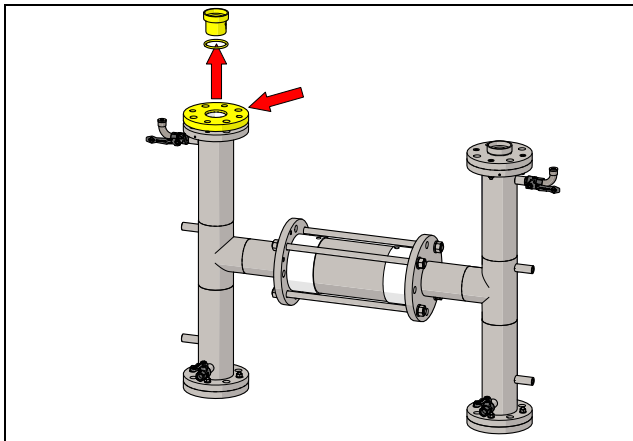

Fig. 3.7.7b
Loose Medium Flange [15] and remove Hose Bush discharge [12] with O-ring Discharge [52].

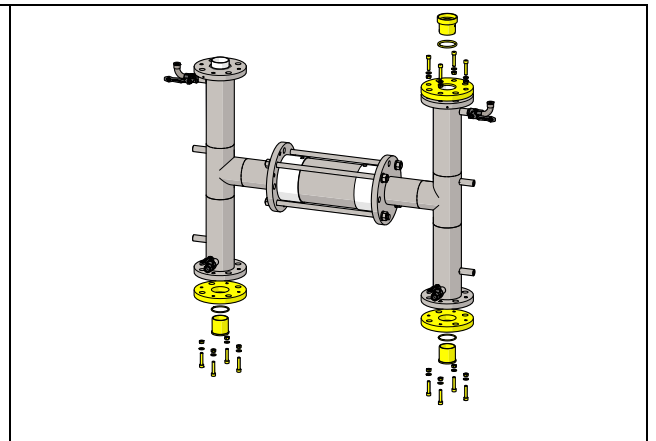

Fig. 3.7.8
Repeat steps 3.5.7 a and b to remove remaining screws, Medium Flanges [15], Hose Bushes [12] - discharge, [9] - suction and O-rings [52 and 72].

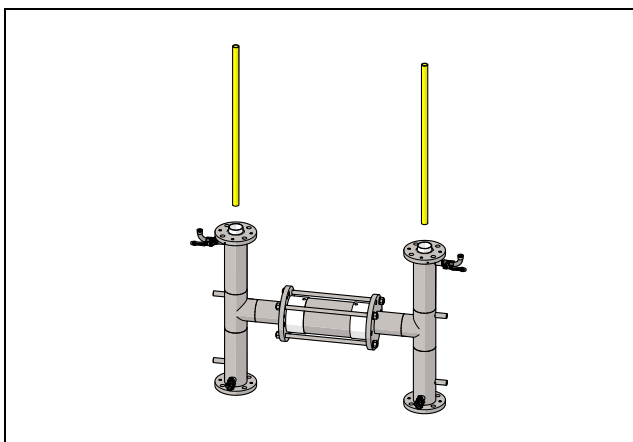

Fig. 3.7.9
Remove Balance Tubes [10].

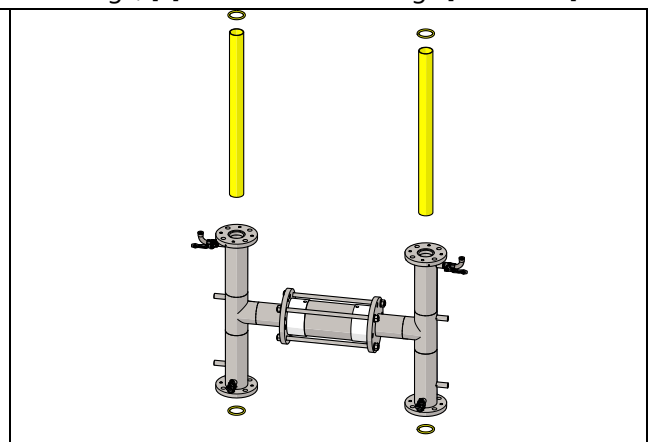

Fig. 3.7.10
Remove Diaphragm O-rings [23] and Tubular Diaphragm [18].

3. MAINTENANCE

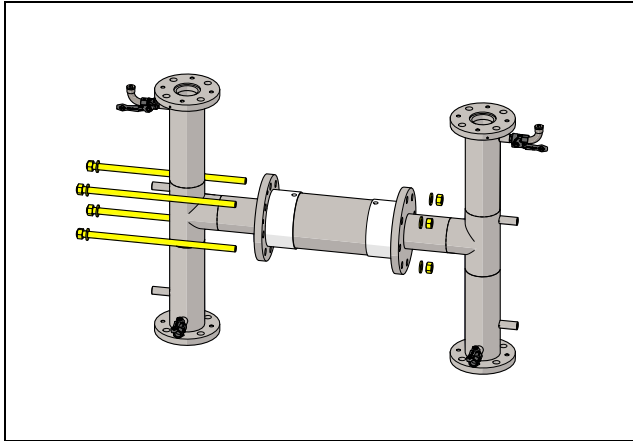

Fig 3.7.11
Remove nuts, washers and Anchor Bolts [8].

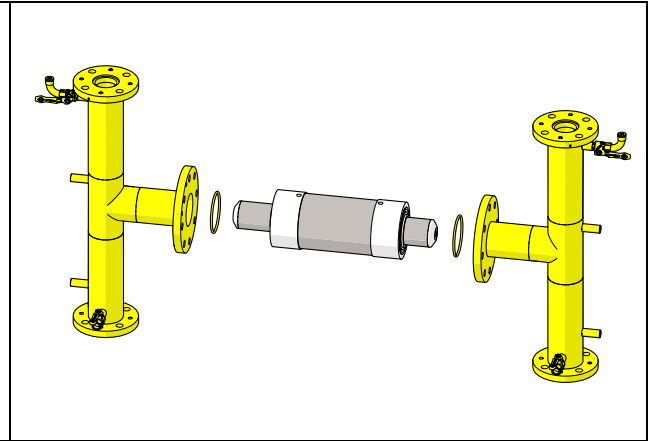

Fig 3.7.12
Disassembly Housing [1] from centre section.

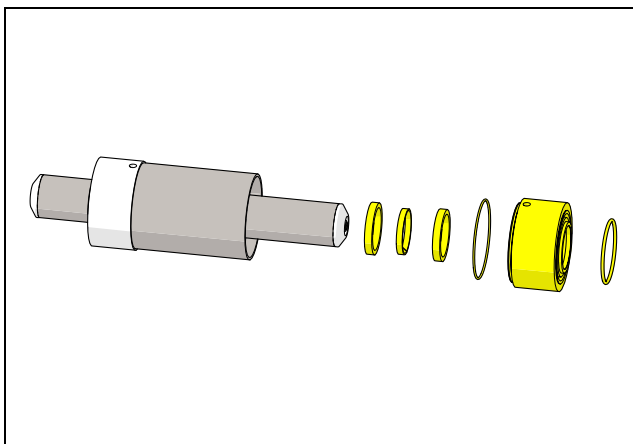

Fig 3.7.13
Remove P-Flange O-ring [51], P-Flange [14], Pneumatic cylinder O-ring [26], Hydraulic Seal Oil Side [25], Slide Ring of Hydraulic Piston [28] and Hydraulic Seal Air Side[22].

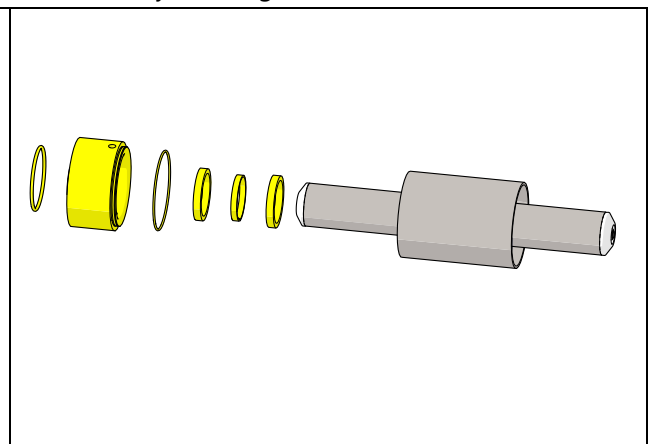

Fig 3.7.14
Repeat steps from 3.5.13 for second side.

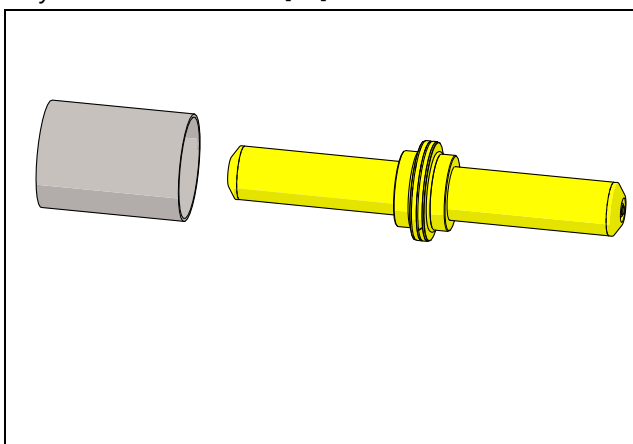

Fig 3.7.15
Disassembly Piston [6] from cylinder [4].

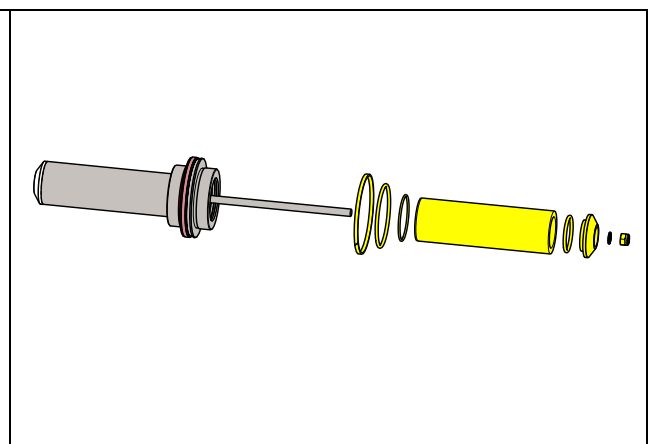

Fig 3.7.16
[46-FP40 or 47-FP50/80] Nut + Sealing Washer; [17] Piston Cover; [29] O-Ring Piston Cover; [7] Piston Hydraulic; [41] O-Ring Piston Hydraulic; [50] O-Ring Muffling Discharge Stroke; [27] Slide Ring Pneumatic Piston.

3. MAINTENANCE

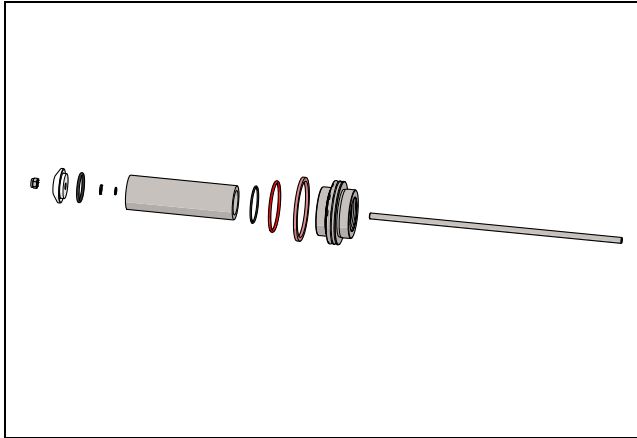

Fig 3.7.17

[46-FP40 or 47-FP50/80] Nut + Sealing Washer; [17] Piston Cover; [29] O-Ring Piston Cover; [7] Piston Hydraulic; [41] O-Ring Piston Hydraulic; [50] O-Ring Muffling Discharge Stroke; [27] Slide Ring Pneumatic Piston.

The pump is now completely disassembled. Check all components for wear or damage and replace if necessary.

3.7. FP/FH – assembly of the pump

The assembly procedure is done in the reverse order to the disassembly.

Nevertheless, there are a few things that you have to remember in order to assemble the pump correctly.

For details see chapter 3.8 “Changing the parts”.

3. MAINTENANCE

3.8. Changing the parts

3.8.1. Changing seals

- Change all seals.
- The hydraulic seals [22, 25] are kidney-shaped and snapped into the groove of the P-flange. Attention: The groove in the seal has always to show to the outside:

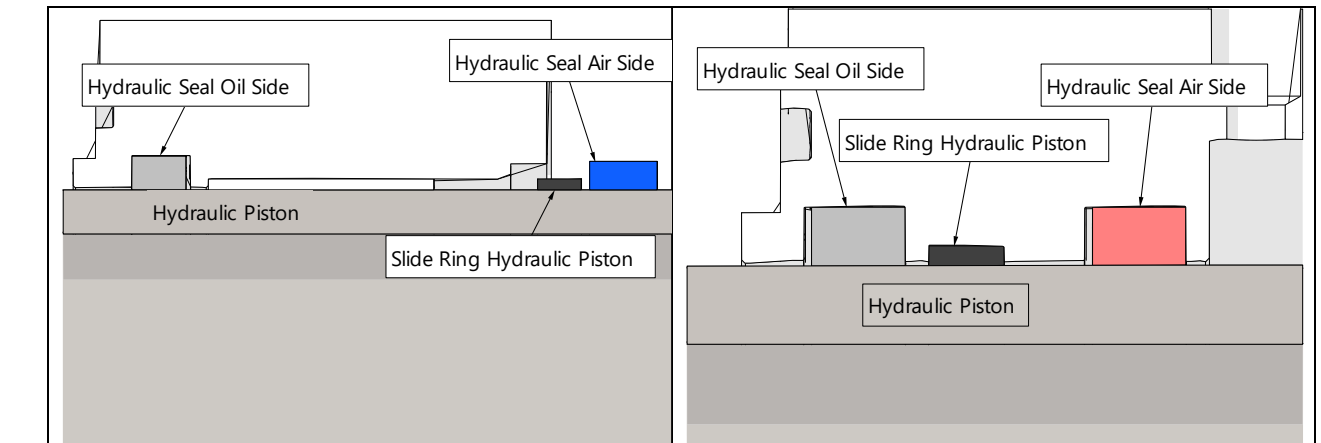

Fig 3.9.1

FP/FH 25 Seals arrangement.

Fig 3.9.2

FP/FH 40 Seals arrangement.

3.8.2. Changing the piston and the cylinder

- Check, if grooves or marks are visible on the surface of the piston or the cylinder. If yes, they must be changed.
- The new piston and cylinder must be greased properly before mounting. Use a high-quality grease.
- Keep care, that the seals are not pressed out of the groove while mounting.

3.8.3. Changing the hose diaphragms

3.8.3.1. Suction Side

- Clean the housing thoroughly and dry it from remaining water with compressed air.
- Put the diaphragm through the housing, so that 40 mm will stay out on the suction side.
- Put a new O-Ring Diaphragm [23] properly greased over the hose into the groove.
- Put the Medium Flange [15] on the suction side over the hose and fix it with the nuts tightened by hand.
- Push the O-Ring Hose Bush Suction [72] over hose bush, grease it well and push the hose bush into the hose diaphragm.
- Press the hose bush with the hose into the housing, so that it is on the same level as the Medium Flange
- Put the balance tube from into the hose diaphragm.
- Assemble (2, 24, 16,19, 20, and 11) and put on the housing, make sure that the balance tube is put over the guiding on ball stop (11).
- Tighten the Screw with Nut (38) and then the nuts on the medium flange.

3. MAINTENANCE

3.8.3.2. Discharge Side

- Put a new O-Ring Diaphragm [23] properly greased over the hose into the groove.
- Put the Medium Flange [15] on the discharge side over the hose and fix it with the nuts tightened by hand.
- Cut the diaphragm with a sharp knife so that 2 mm are remaining over the medium flange.
- Grease the hose bush discharge and put the O-Ring [52] over the hose bush. (Only metal pumps)
- Press the hose bush into the hose. Make sure that the hose does not slide into the medium flange. Fix the hose with a screwdriver from the side if needed. Make sure that the balance tube is inside the hose bush. When the hose bush is pushed completely in the medium flange, Assemble (1, 24, 16,19, 20, and 11) and tighten the Screw with Nut (38) and then the nuts on the medium flange.

3.9. Filling of Hydraulic Liquid

There are two different methods of filling the pump. This depends on the local circumstances:

3.9.1. Pump is flooded from the suction side

When the suction side of the pump is flooded, follow the instructions here. Otherwise, when the pump has to suck from a tank below the pump level, see chapter 3.10.2. The pump is flooded, when the level of the slurry in the tank is over the discharge manifold of the pump. If this is not the case, the pump can be flooded by a water connection on the suction side.

- The advantage with a flooded pump is the fact, that the pressure of the slurry opens the diaphragm in the manifold.
- The pump has to be assembled complete and installed in the plant with all connections.
- The valve from the slurry tank has to be opened, so that the slurry flows into the pump
- to open the hose diaphragm.
- Switch on the control power and leave the air supply open.
- Close the drain nozzle on the downside of the housing.
- Open the oil filling nozzle on the top of the housing
- Remove one sensor cable, pump will make one stroke and stop. Fill opposite side with hydraulic liquid.
- Screw out the ventilation screw (4 mm) from the side of the lower flange on the top of the pump.
- Fill in the oil, till it comes out of the ventilation hole.
- Screw in the ventilation screw.
- Close the filling nozzle. Single acting pump (FP25) is now ready for operation. At the double acting pumps remove other cable from sensor then put first cable back, pump will make one stroke, so that the piston moves to the left side. Attention! Piston moves only, when the valve on the discharge is opened. Now the right side can be filled like described above.
- Put all cables back and pump is ready.

3. MAINTENANCE

3.9.2. Pump is not flooded

When the pump is not flooded, the following steps has to be done:

- Block outlet of the pump.
- Put 1bar of air on suction side on the pump to expand hoses.
- then follow procedure 3.10.1

3.9.3. Changing stroke sensors

In case that a stroke sensor must be changed screw out the old sensor by locking the two nuts against each other in the position they have. Measure the distance from the sensor face to the next nut and adjust the nuts on the new sensor in the same way. Attention! Before a new sensor is screwed into the P-flange move the pneumatic piston manually by pressing the small button on the air valve into this position where the new sensor will be screwed in. When no distance from the old sensor is available, screw the new sensor carefully into the P-flange till it touches the pneumatic piston and turn it back one turn.

3.9.4. Test run



We recommend you conduct a test run of the pump before installing it in the system, so no liquid gets wasted if the pump leaks or perhaps does not start accordingly to wrong assembly of the pump. **After a few weeks of operation retighten the nuts with appropriate torque.**

4. SPARE PARTS

4. SPARE PARTS

4.1. FP-FH 25 – Spare parts drawings

4.1.1. Suction side

The quantities given apply to entire pump.

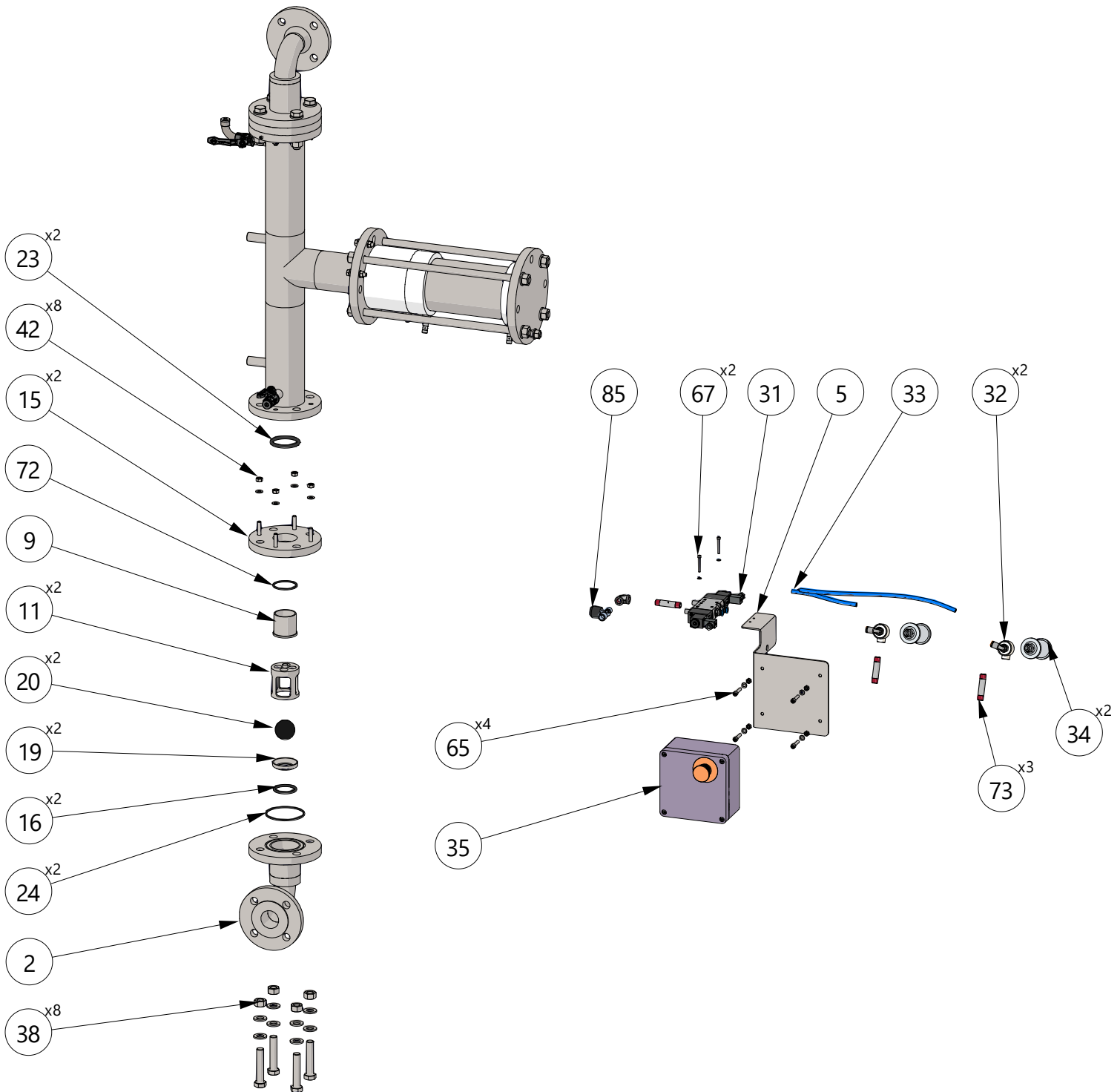

4. SPARE PARTS

4.1.2. Discharge side

The quantities given apply to entire pump.

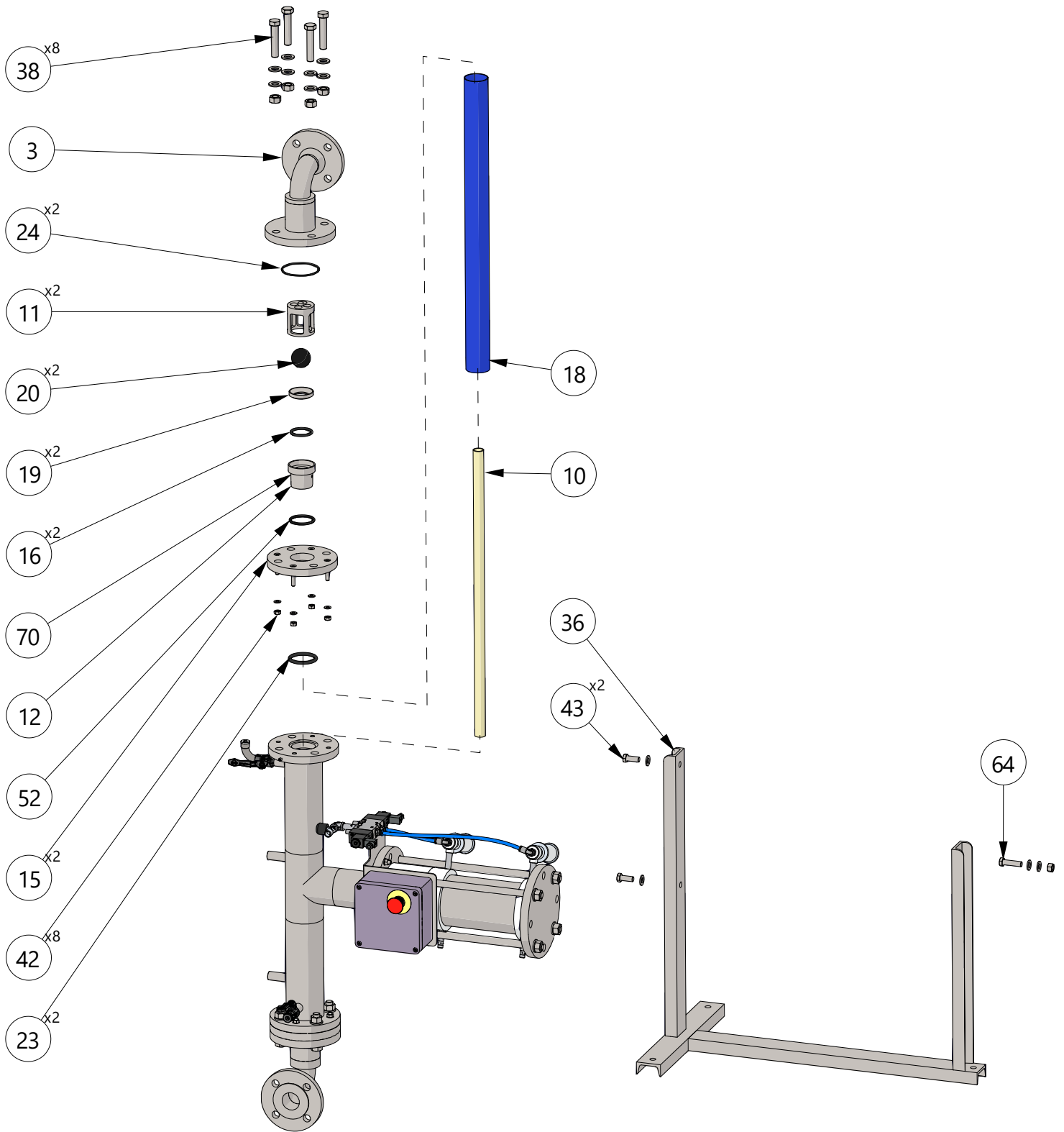

4. SPARE PARTS

4.1.3. Cylinder section

The quantities given apply to entire pump.

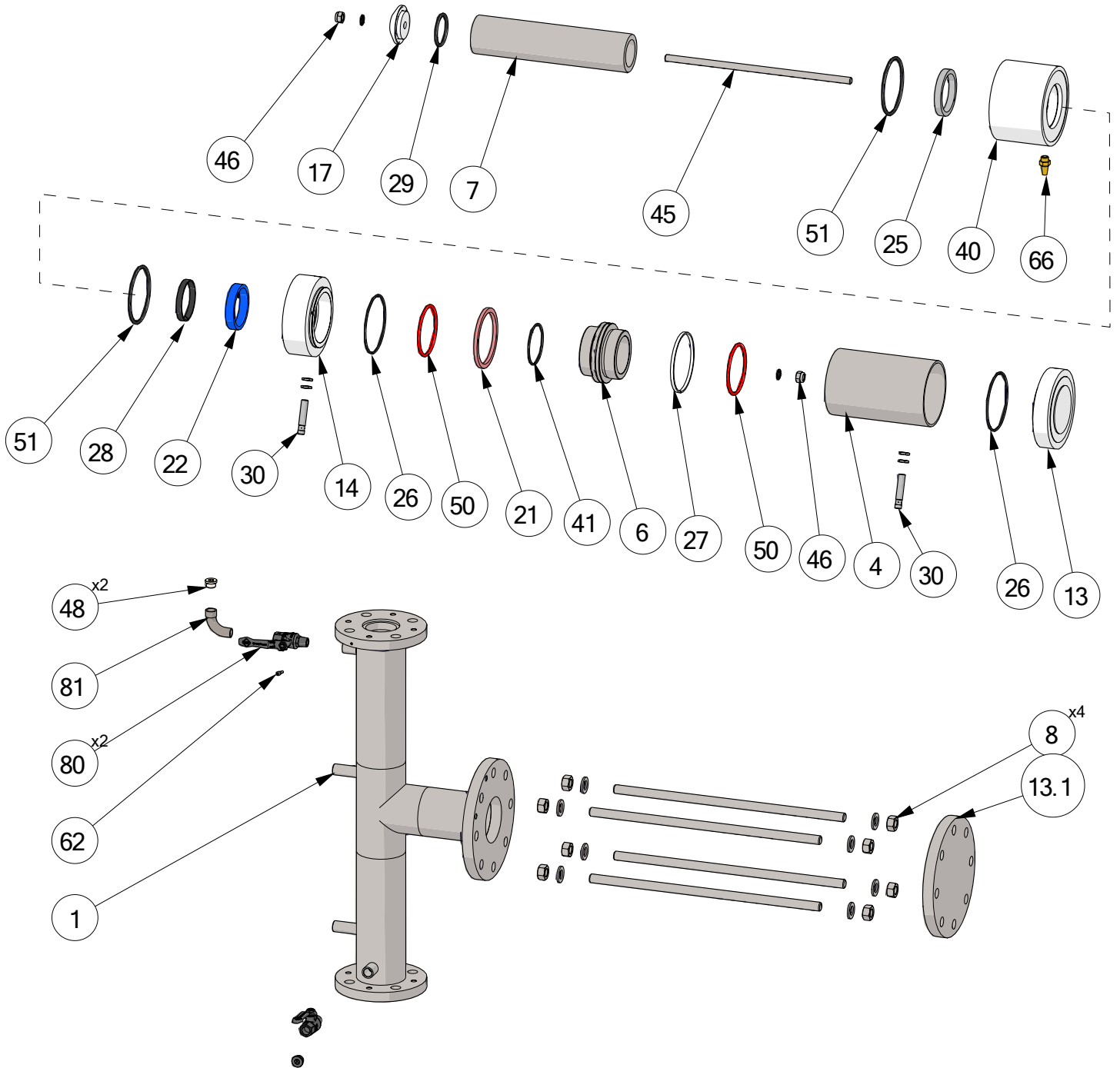

4. SPARE PARTS

4.2. FP-FH 25 – Spare parts list

Pos.	Q-ty	Description	Material	Article number
1	1	Housing	Steel	11-40C0101R
2	1	Suction Manifold thread	Steel	11-25C0201-G
	1	Suction Manifold flange	Steel	11-25C0201-F
	1	Suction Manifold flange	PP	11-40C0231-F
	1	Suction Manifold thread	stainless steel	11-25C0206-G
	1	Suction Manifold flange	stainless steel	11-25C0206-F
	3	1	Discharge Manifold thread	Steel
1		Discharge Manifold flange	Steel	11-25C0301-F
1		Discharge Manifold flange	PP	11-40C0331-F
1		Discharge Manifold thread	stainless steel	11-25C0306-G
1		Discharge Manifold flange	stainless steel	11-25C0306-F
4	1	Cylinder Pneumatik FP	Steel	11-25C0401
	1	Cylinder Pneumatik FH	Steel	11-40C0401
5	1	Valve Frame	AISI 304L	11-40E0506
6	1	Piston Pneumatic FP	Steel	11-25C0601
	1	Piston Pneumatic FH	Steel	11-25H0601
7	1	Piston Hydraulic	Steel/Chrome	11-25E0702
8	4	Anchor Bolt outside	Steel	11-25E0804
9	1	Hose Bush suction	Steel	11-40C0901
	1		PP	11-40C0931
	1		stainless steel	11-40C0906
10	1	Balance Tube	PP	11-40C1031
11	2	Ball Retainer	Steel	11-4001101
	2		PP	11-4001131
	2		stainless steel	11-4001106
12	1	Hose Bush discharge	Steel	11-40C1201
	1		PP	11-40C1231
	1		stainless steel	11-40C1206
13	1	End Flange FP	Aluminium	11-25C1302
	1	End Flange FH	Aluminium	11-25H1302
13.1	1	Blind Flange	Steel	11-25C1301
14	1	P-Flange FP	Aluminium	11-25E1410
	1	P-Flange FH	Aluminium	11-25H1410
15	2	Medium Flange	Steel	11-4001501
	2		stainless steel	11-4001506
16	2	O-Ring Valve Seat	NBR	11-4001620
17	1	Piston Cover	Aluminium	11-40C1710
18	1	Tubular Diaphragm	Superflex	11-40C1830
	1		PUR blue	11-40C1836
19	2	Valve Seat	Steel	11-4001901
	2		PE1000	11-4001932
	2		stainless steel	11-4001906
20	2	Valve Ball	NBR	6-200-23-3
	2		PU	6-200-23-4
	2		PTFE-TFM	6-200-23-1-5
	2		PE1000	6-200-23-22
	2		CR Steel core	11-4002024

4. SPARE PARTS

21	1	Pneumatic Seal w. back-up FP	PUR/NBR	11-25C2120
	1	Pneumatic Seal w. back-up FH	PUR/NBR	11-40C2120
22	1	Hydraulic Seal Air side	PUR blue	11-25E2236
23	2	O-Ring Diaphragm	NBR	11-4002320
24	2	O-Ring Flange	NBR	11-4002420
25	1	Hydraulic Seal Oil side	PUR grey	11-40E2536
26	2	O-Ring Pneumatic Cylinder FP	NBR	11-4002620
	2	O-Ring Pneumatic Cylinder FH	NBR	11-40C2620
27	1	Slide Ring Pneumatic Piston FP	PTFE compound	11-25C2734
	1	Slide Ring Pneumatic Piston FH	PTFE compound	11-40C2734
28	1	Slide Ring Hydraulic Piston	PTFE compound	11-40C2834
29	1	O-Ring Piston Cover	NBR	11-40C2920
30	2	Inductive sensor	-	11-4003090
31	1	Solenoid Valve	Aluminium	11-40E3190
32	2	Quick exhaust valve	Brass/Nickel	11-40E3290
33	2	Air Hose	PUR	11-40E3337
34	2	Muffler	Aluminium	11-40E3410
35	1	Control Box	Plastic	11-4003590
36	1	Base Frame	Steel	11-25E3601
38	8	Screw with Nut	8.8 Zn	11-40C3804
40	1	Leading flange	Aluminium	11-25E4010
41	1	O-Ring Piston Hydraulic	NBR	11-40E4120
42	8	Screw with Nut	8.8 Zn	11-2503504
43	2	Screw with washer	8.8 Zn	11-4004304
45	1	Anchor Screw	Steel	11-25E4501
46	2	Sealing Nut with washer	Steel/Seal	11-40C4690
48	2	Plug	Brass/Nickel	11-4004803
50	2	O-Ring Muffling Discharge Stroke FP	PUR red	11-40E5036
	2	O-Ring Muffling Discharge Stroke FH	PUR red	11-40C5036
51	2	O-Ring P-Flange	NBR	11-40C5120
52	1	O-Ring Discharge C/S	NBR	11-4005220
	1	O-Ring Discharge PP	NBR	11-40C5220
61	2	Screw with Washer	8.8 Zn	11-2506104
62	1	Ventilation Screw	8.8 Zn	11-4006206
64	1	Screw with nut and washers	8.8 Zn	11-25E6404
65	4	Screw with nut and washers for control box assembly	A4-70	11-40E6506
66	1	Muffler	Bronze	11-40E6611
67	2	Screw with nut and 2 washers	A4-70	11-40E6706
70	1	Bolt hose bush (included in pos. 12)	Steel	11-4007001
	1		PP	11-4007031
	1		stainless steel	11-4007006
72	1	O-Ring Hose Bush suction	NBR	11-40E7220
73	3	Barrel Nipple	AISI 316L	11-40E7306
80	2	Ball Valve	Brass/Nickel	11-40E8003
81	1	Elbow 90°	Zinc coated steel	11-4008104
85	1	Needle Valve Air Inlet + elbow	Brass/Nickel	11-40E8591

4. SPARE PARTS

4.3. FP-FH 40 – Spare parts drawing

4.3.1. Suction side

The quantities given apply to entire pump.

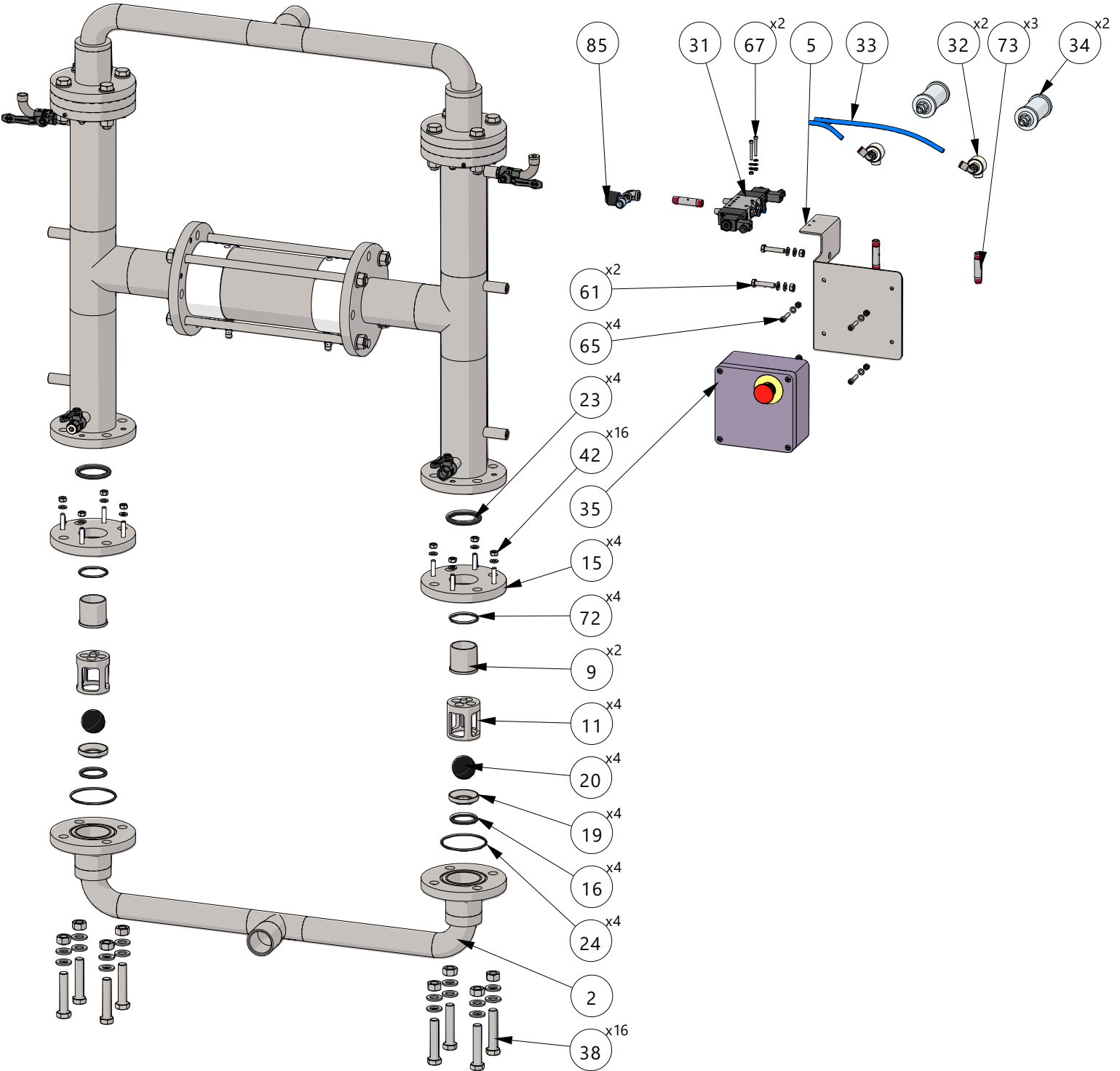

4. SPARE PARTS

4.3.2. Discharge side

The quantities given apply to entire pump.

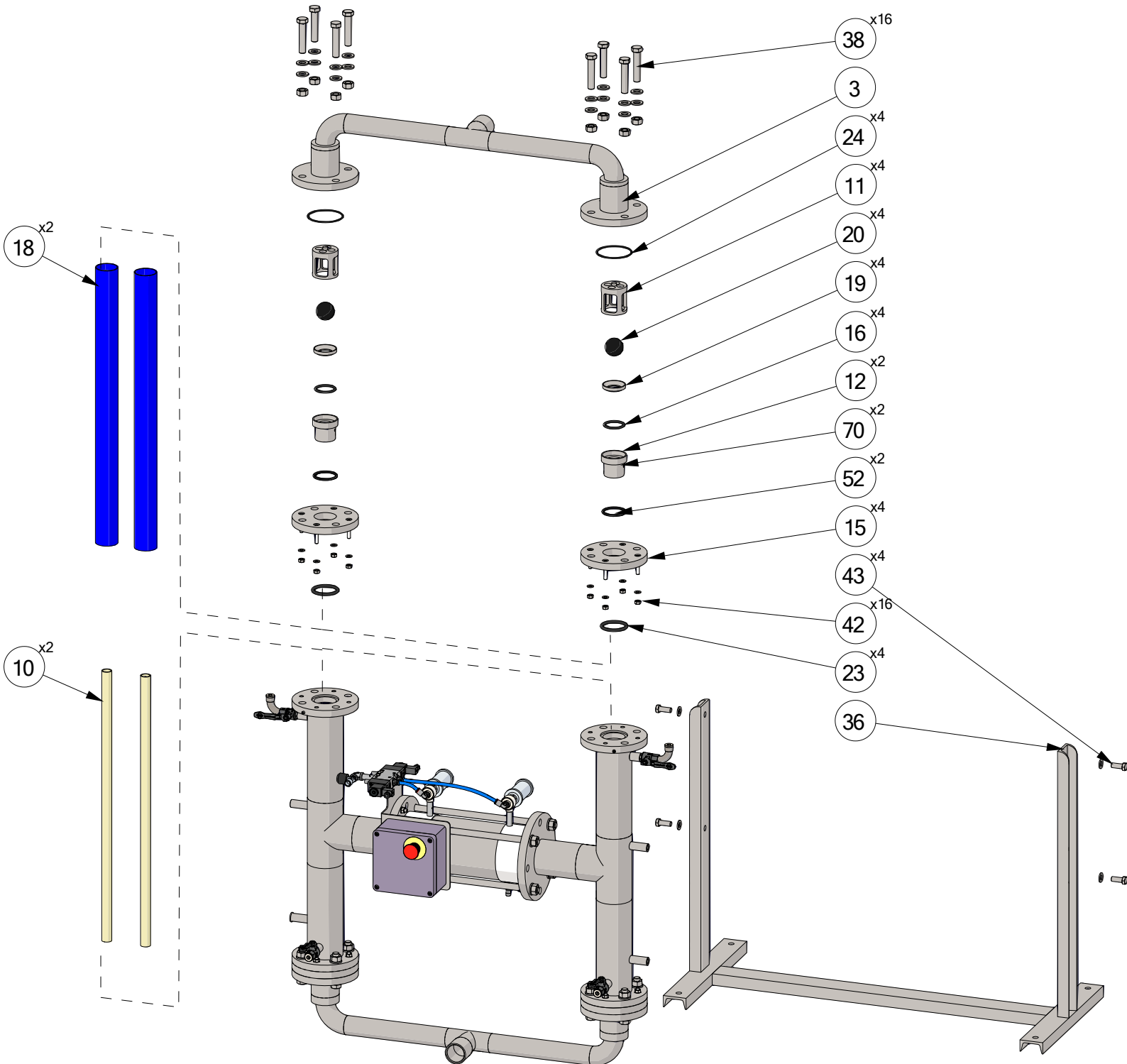

4. SPARE PARTS

4.3.3. Cylinder section

The quantities given apply to entire pump.

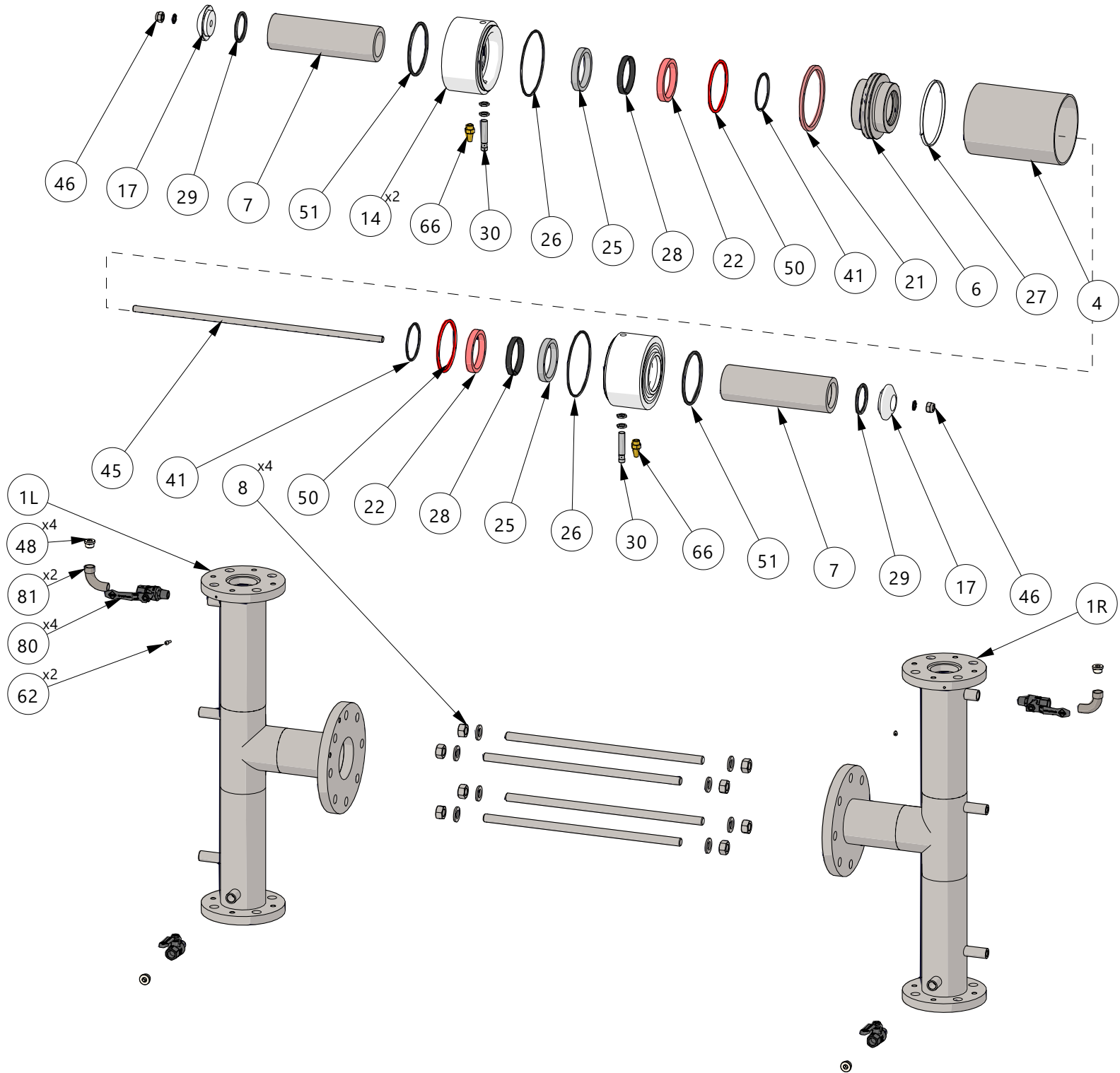

4. SPARE PARTS

4.3.4. Optional PP manifold

The quantities given apply to one manifold.

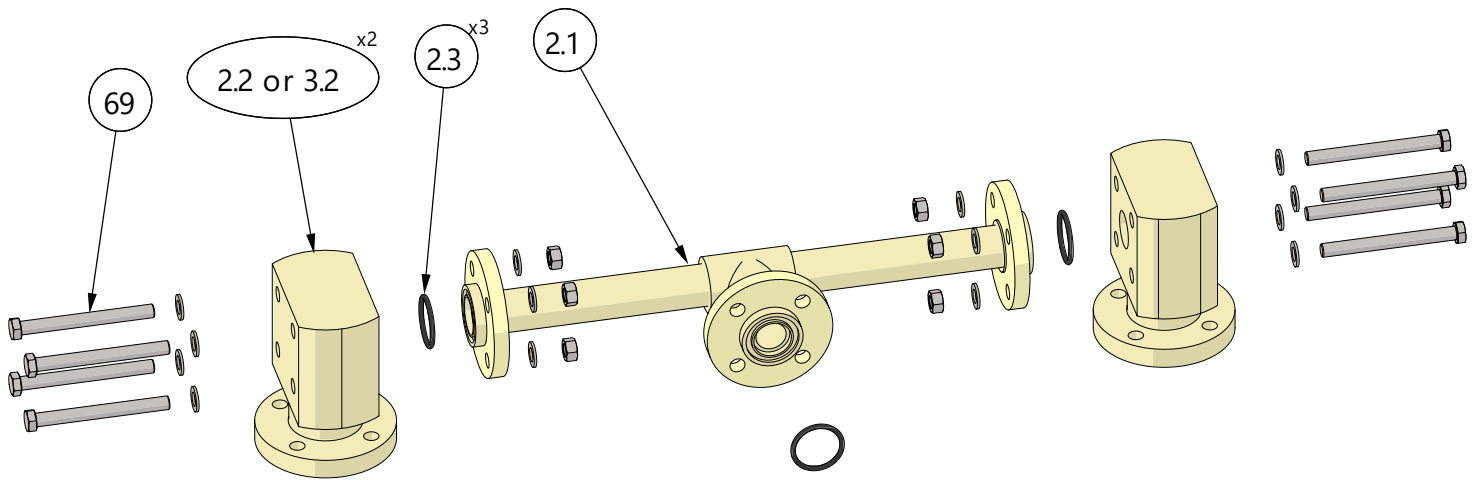

4.4. FP-FH 40 – Spare parts list

Pos.	Q-ty	Description	Material	Article number
1R	1	Housing right	Steel	11-40C0101R
1L	1	Housing left	Steel	11-40C0101L
2	1	Suction Manifold thread	Steel	11-40E0201-G
	1	Suction Manifold thread	stainless steel	11-40C0206-G
	1	Suction Manifold flange	stainless steel	11-40C0206-F
	1	Suction Manifold flange	Steel	11-40E0201-F
2.2	2	Suction Manifold pot	PP	11-40C0231-F
2.1	1	Manifold connection pipe	PP	11-40C0231-C
2.3	3	O-ring PP flange with connection pipe	NBR	11-40E6821
3	1	Discharge Manifold thread	Steel	11-40C0301-G
	1	Discharge Manifold thread	stainless steel	11-40C0306-G
	1	Discharge Manifold flanged	stainless steel	11-40E0306-F
	1	Discharge Manifold flanged	Steel	11-40C0301-F
3.2	2	Discharge Manifold pot	PP	11-40C0331-F
2.1	1	Manifold connection pipe	PP	11-40C0231-C
2.3	3	O-ring PP flange with connection pipe	NBR	11-40E6821
4	1	Cylinder Pneumatik FP	Steel	11-40C0401
	1	Cylinder Pneumatik FH	Steel	11-40HC0401
5	1	Valve Frame	AISI 304L	11-40E0506
6	1	Piston Pneumatic FP	Steel	11-40C0601
	1	Piston Pneumatic FH	Steel	11-4HC0601

4. SPARE PARTS

7	2	Piston Hydraulic	Steel/Chrome	11-40C0702
8	4	Anchor Bolt outside	Steel	11-40E0804
9	2	Hose Bush suction	Steel	11-40C0901
	2		PP	11-40C0931
	2		stainless steel	11-40C0906
10	2	Balance Tube	PP	11-40C1031
11	4	Ball Retainer	Steel	11-4001101
	4		PP	11-4001131
	4		stainless steel	11-4001106
12	2	Hose Bush discharge (including pos. 70)	Steel	11-40C1201
	2		PP	11-40C1231
	2		stainless steel	11-40C1206
14	2	P-Flange FP	Aluminium	11-40E1410
	2	P-Flange FH	Aluminium	11-40HC1410
15	4	Medium Flange	Steel	11-4001501
	4		stainless steel	11-4001506
16	4	O-Ring Valve Seat	NBR	11-4001620
17	2	Piston Cover	Aluminium	11-40C1710
18	2	Tubular Diaphragm	Superflex	11-40C1830
	2		PUR blue	11-40C1836
19	4	Valve Seat	Steel	11-4001901
	4		PE1000	11-4001932
	4		stainless steel	11-4001906
20	4	Valve Ball	NBR	6-200-23-3
	4		PU	6-200-23-4
	4		PTFE-TFM	6-200-23-1-5
	4		PE1000	6-200-23-22
	4		CR Steel core	11-4002024
21	1	Pneumatic Seal w. back-up FP	PUR/NBR	11-40C2120
	1	Pneumatic Seal w. back-up FH	PUR/NBR	11-4HC2120
22	2	Hydraulic Seal Air side	PUR red	11-40E2236
23	4	O-Ring Diaphragm	NBR	11-4002320
24	4	O-Ring Flange	NBR	11-4002420
25	2	Hydraulic Seal Oil side	PUR grey	11-40E2536
26	2	O-Ring Pneumatic Cylinder FP	NBR	11-40C2620
	2	O-Ring Pneumatic Cylinder FH	NBR	11-4HC2620
27	1	Slide Ring Pneumatic Piston FP	PTFE compound	11-40C2734
	1	Slide Ring Pneumatic Piston FH	PTFE compound	11-4HC2734
28	2	Slide Ring Hydraulic Piston	PTFE compound	11-40C2834
29	2	O-Ring Piston Cover	NBR	11-40C2920
30	2	Inductive sensor	-	11-4003090
31	1	Solenoid Valve	Aluminium	11-40E3190
32	2	Quick exhaust valve	Brass/Nickel	11-40E3290
33	2	Air Hose	PUR	11-40E3337
34	2	Muffler	Aluminium	11-40E3410

4. SPARE PARTS

35	1	Control Box	Plastic	11-4003590
36	1	Base Frame	Steel	11-40E3601
38	16	Screw with Nut	8.8 Zn	11-40C3804
41	2	O-Ring Piston Hydraulic	NBR	11-40E4120
42	16	Nut with washer	8.8 Zn	11-2503504
43	4	Screw with washer	8.8 Zn	11-40E4304
45	1	Anchor Screw	Steel	11-40E4504
46	2	Sealing Nut	Steel/Seal	11-40C4690
48	4	Plug	Brass/Nickel	11-4004803
50	2	O-Ring Muffling Discharge Stroke	PUR red	11-40C5036
51	2	O-Ring P-Flange	NBR	11-40C5120
52	2	O-Ring Discharge C/S	NBR	11-4005220
	2	O-Ring Discharge PP	NBR	11-40C5220
61	2	Screw with Washer	8.8 Zn	11-2506104
62	2	Ventilation Screw	8.8 Zn	11-50E6206
65	4	Screw with nut and washers for control box assembly	A4-70	11-40E6506
66	2	Muffler	Bronze	11-40E6611
67	2	Screw with nut and 2 washers	A4-70	11-40E6706
69	16	Screw with nut and washers for PP flange with connection pipe	St 8.8 Zn	11-40E6904
70	2	Bolt hose bush (included in pos. 12)	Steel	11-4007001
	2		PP	11-4007031
	2		stainless steel	11-4007006
72	2	O-Ring Hose Bush suction	NBR	11-40E7220
73	3	Barrel Nipple	AISI 316L	11-40E7306
80	4	Ball Valve	Brass/Nickel	11-40E8003
81	2	Elbow 90°	Zinc coated steel	11-4008104
85	1	Needle Valve Air Inlet	Brass/Nickel	11-40E8591

4. SPARE PARTS

4.5. FP-FH 50/80 – Spare parts drawing

4.5.1. Suction side

The quantities given apply to entire pump.

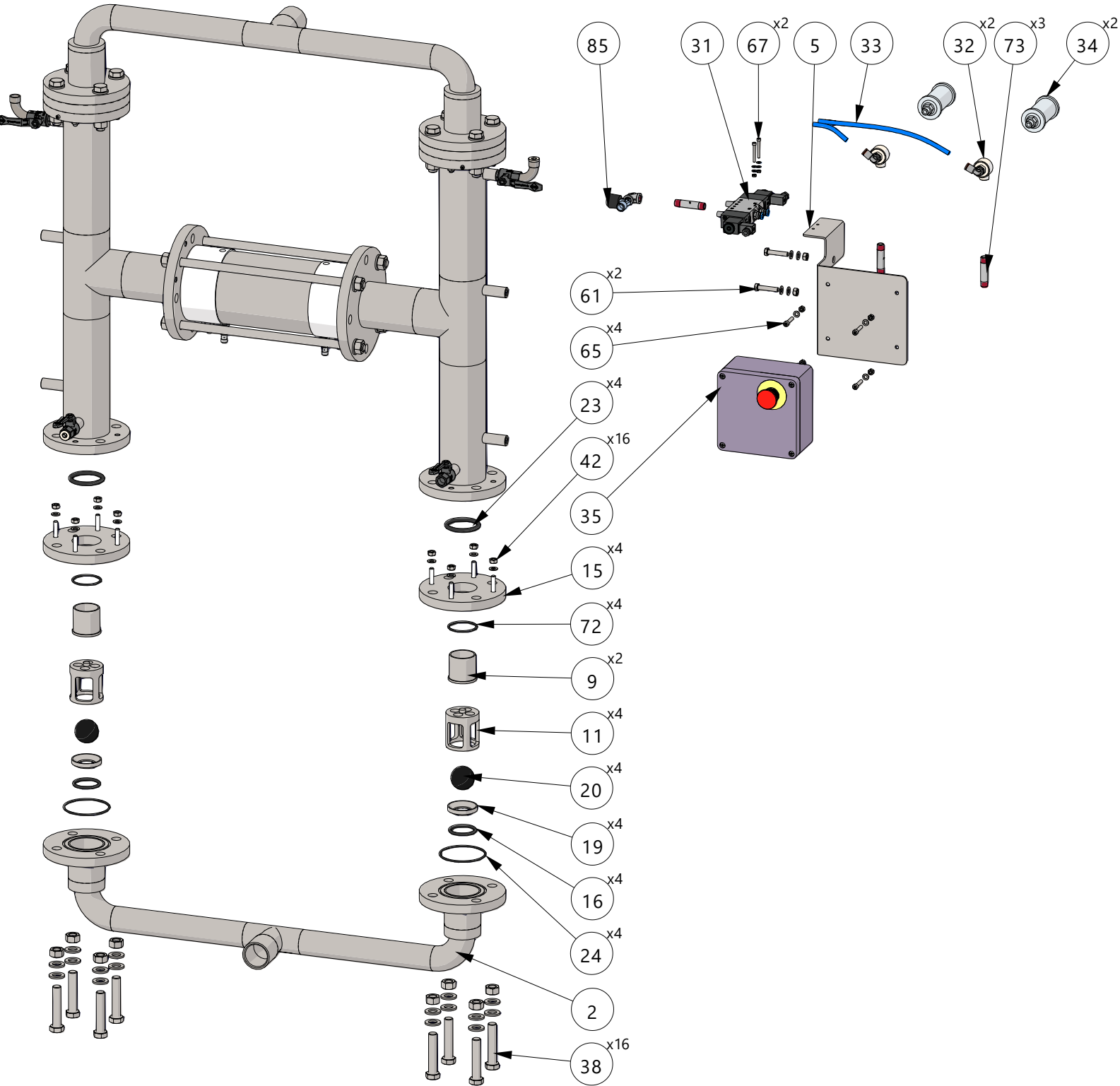

4. SPARE PARTS

4.5.2. Discharge side

The quantities given apply to entire pump.

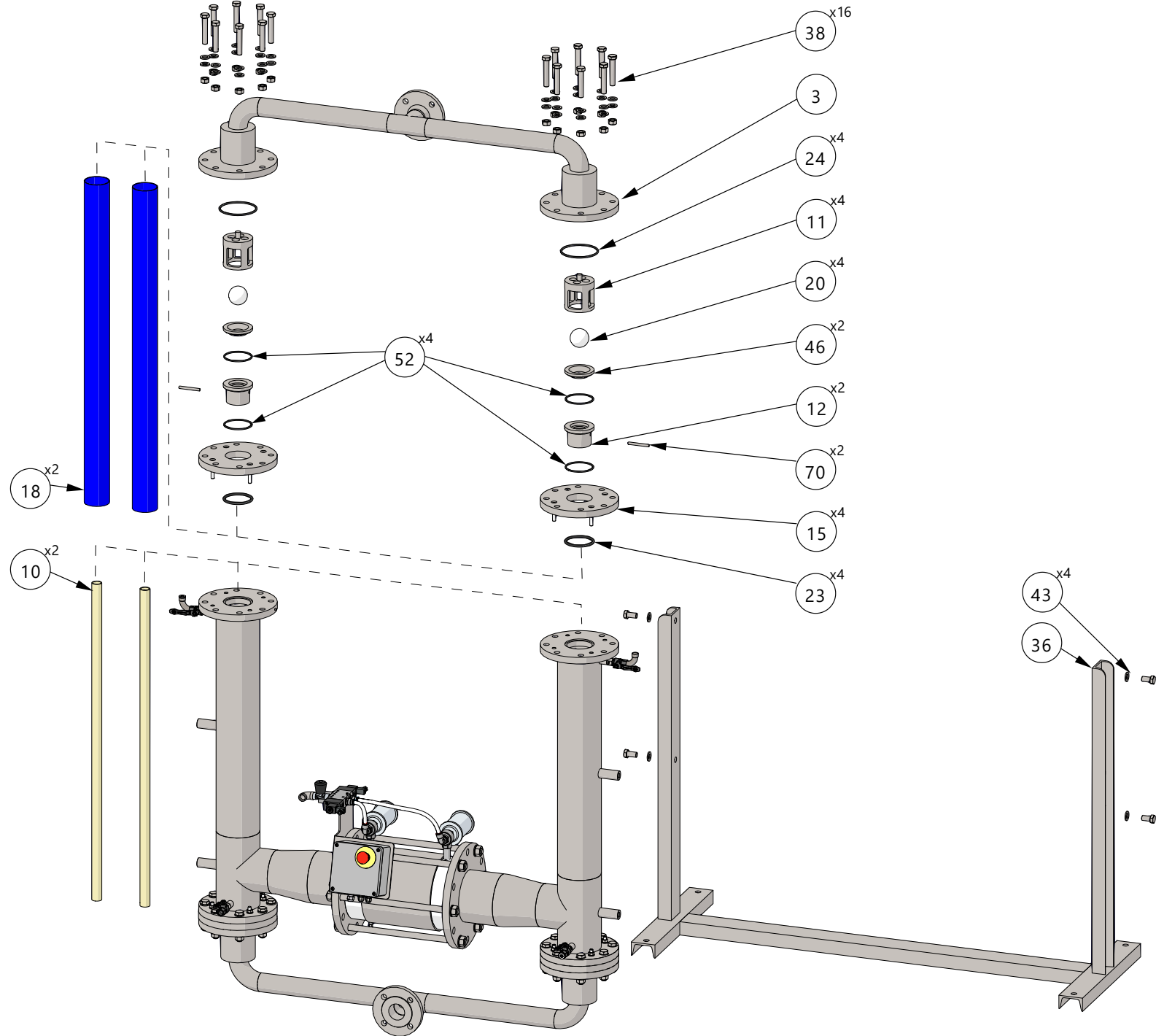

4. SPARE PARTS

4.5.3. Cylinder section

The quantities given apply to entire pump.

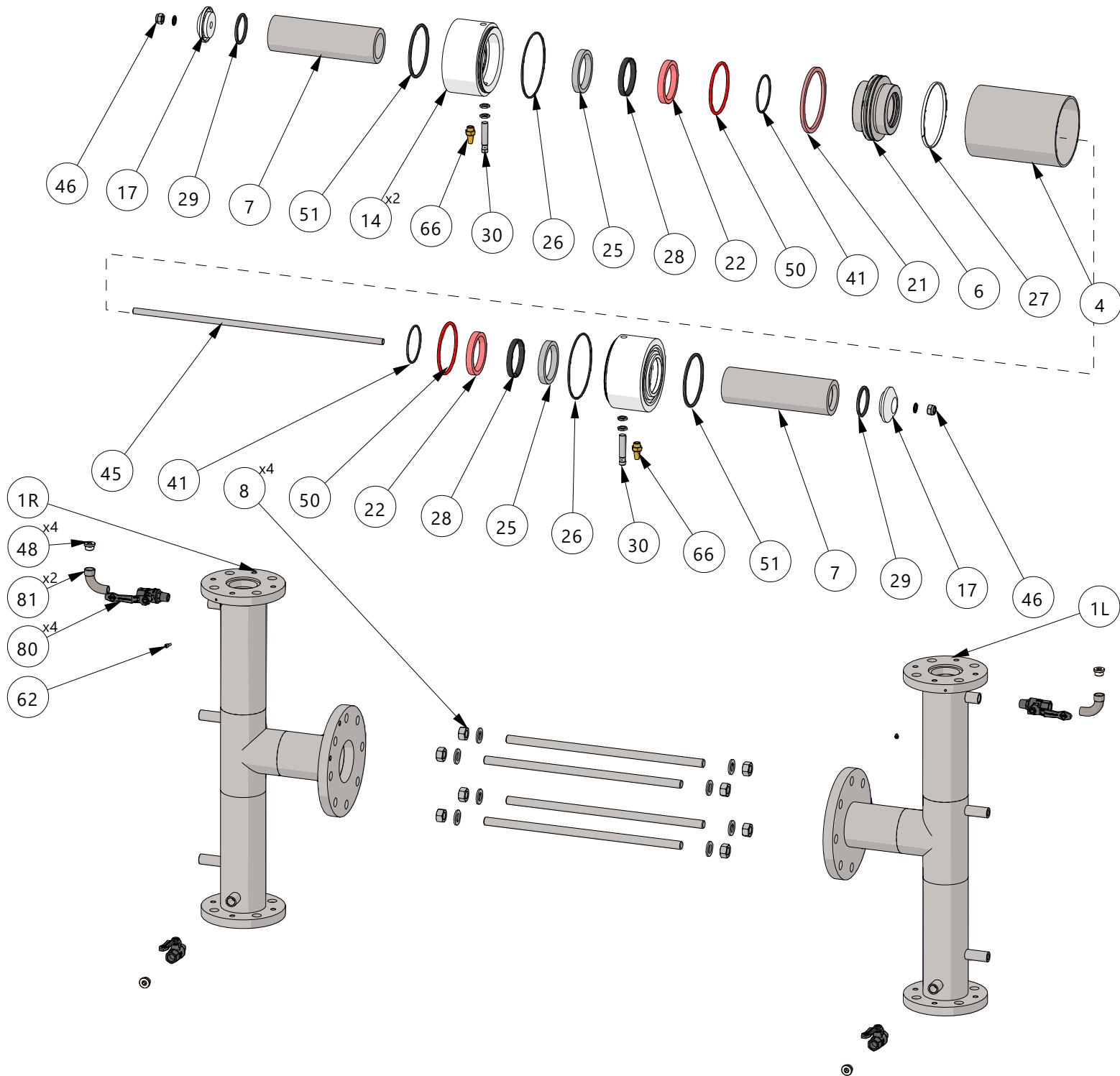

4. SPARE PARTS

4.6. FP-FH 50/80 – Spare parts list

Pos.	Q-ty	Description	Material	Article number
1	1	Housing right	steel	11-50C0101-R
	1	Housing left	steel	11-50C0101-L
2	1	Suction Manifold thread 50	steel	11-50C0201
	2	Suction Manifold flange 50	PP	11-50C0231
	1	Suction Manifold flange 50	PP	11-50C0231-C
	1	Suction Manifold thread 50	stainless steel	11-50C0206
	1	Suction Manifold thread 80	steel	11-80C0201
	2	Suction Manifold flange 80	PP	11-80C0231
	1	Suction Manifold flange 80	PP	11-80C0231-C
	1	Suction Manifold thread 80	stainless steel	11-80C0206
	3	1	Discharge Manifold thread 50	steel
2		Discharge Manifold flange 50	PP	11-50C0331
1		Discharge Manifold flange 50	PP	11-50C0231-C
1		Discharge Manifold thread 50	stainless steel	11-50C0306
1		Discharge Manifold thread 80	steel	11-80C0301
2		Discharge Manifold flange 80	PP	11-80C0331
1		Discharge Manifold flange 80	PP	11-80C0231-C
1		Discharge Manifold thread 80	stainless steel	11-80C0306
4	1	Cylinder Pneumatik FP	Steel	11-50C0401
	1	Cylinder Pneumatik FH	Steel	11-5HC0401
5	1	Valve Frame	AISI 304L	11-50C0506
6	1	Piston Pneumatic FP	Steel	11-50C0610
	1	Piston Pneumatic FH	Steel	11-5HC0610
7	2	Piston Hydraulic	Aluminum	11-50E0701
8	6	Anchor Bolt outside	St60	11-50C0804
9	2	Hose Bush suction for Superflex diaphragm	steel	11-5000901
	2		PP	11-5000931
	2		stainless steel	11-5000906
	2	Hose Bush suction for PUR diaphragm	steel	11-5000901-U
	2		PP	11-5000931-U
	2		stainless steel	11-5000906-U
10	2	Balance Tube	PP	11-50C1031
11	4	Ball Retainer	steel	11-5001101
	4		PP	11-5001131
	4		stainless steel	11-5001106
12	2	Hose Bush discharge for Superflex diaphragm	steel	11-5001201
	2		PP	11-5001231
	2		stainless steel	11-5001206
	2	Hose Bush discharge for PUR diaphragm	steel	11-5001201-U
	2		PP	11-5001231-U
	2		stainless steel	11-5001206-U
14	2	P-Flange FP	Aluminum	11-50E1410
	2	P-Flange FH	Aluminum	11-5HE1410
15	4	Medium Flange	steel	11-5001501
	4		stainless steel	11-5001506
16	2	O-Ring Valve Seat	NBR	11-5001620

4. SPARE PARTS

17	2	Piston Cover	Aluminum	11-50C1710
18	2	Tubular Diaphragm	Superflex	11-50C1830
	2		PUR	11-50C1836
19	2	Valve Seat suction	steel	11-5001901
	2		PP	11-5001931
	2		stainless steel	11-5001906
20	4	Valve Ball	NBR	6-400-23-3
	4		PU	6-400-23-4
	4		PTFE-TFM	6-400-23-1-5
	4		PE1000	6-400-23-22
	4		CR Steel core	11-5002024
21	1	Pneumatic Seal FP	PUR	11-50C2136
	1	Pneumatic Seal FH	PUR	11-5HC2136
22	2	Hydraulic Seal Air Side	PUR red	11-50E2236
23	4	O-Ring Diaphragm	NBR	11-5002320
24	4	O-Ring Flange	NBR	11-5002420
25	2	Hydraulic Seal Oil Side	PUR grey	11-50E2536
26	2	O-Ring Pneumatic Cylinder FP	NBR	11-50C2620
	2	O-Ring Pneumatic Cylinder FH	NBR	11-5HC2620
27	1	Slide Ring Pneumatic Piston FP	PTFE compound	11-50C2735
	1	Slide Ring Pneumatic Piston FH	PTFE compound	11-5HC2735
28	2	Slide Ring Hydraulic Piston	PTFE compound	11-50C2834
29	2	O-Ring Piston Cover	NBR	11-50C2920
30	2	Inductive sensor	-	11-4003090
31	1	Solenoid Valve	Body only	11-50E3190
32	2	Quick exhaust valve	Brass/Nickel	11-50C3290
33	2	Air Hose	NBR	11-50C3337
34	2	Muffler	incl. Oil strainer	11-5003410
35	1	Control Box	Plastic	11-4003590
36	1	Base Frame	steel	11-50C3601
38	32	Screw with Nut	8.8 ZN	11-5003804
41	2	O-Ring Piston Hydraulic	NBR	11-50C4120
42	16	Nut and Washer	8.8 ZN	11-5004204
43	4	Screw with Washer	8.8 ZN	11-50E4304
45	1	Anchor Screw	St60	11-50E4504
46	2	Valve Seat discharge	steel	11-5004602
	2		PP	11-5004631
	2		stainless steel	11-5004606
47	2	Sealing Nut	Steel	11-50C4790
48	4	Plug	Brass/Nickel	11-4004803
50	2	O-Ring Muffling Discharge Stroke	PUR	11-50C5036
51	2	O-Ring P-Flange	NBR	11-5002620
52	2	O-Ring Discharge	NBR	11-5005220
61	3	Screw with Washer	8.8 ZN	11-2506104
62	2	Ventilation Screw	8.8 ZN	11-50E6206
63	2	Muffler Bronze	Bronze	11-50C6311
65	4	Screw with nut and washers for control box assembly	A4-70	11-40E6506
70	2	Bolt hose bush (included in pos. 12)	steel	11-5007001
	2		PP	11-5007031

4. SPARE PARTS

	2		stainless steel	11-5007006
72	2	O-Ring Hose Bush suction	NBR	11-50E7220
73	2	Barrel Nipple	-	11-50E7306
74	4	Adapter	Steel	11-50E7401
80	4	Ball Valve	Brass/Nickel	11-40E8003
81	2	Elbow 90°	Zinc coated steel	11-4008104
85	1	Needle Valve Air Inlet	Brass/Nickel	11-5008511

4. SPARE PARTS

4.7. Stocking recommendation

Even at normal operation some details in the pump will be worn. In order to avoid expensive breakdowns, we recommend having a few spare parts in stock.

Depending on the severity of the operation and the importance of assuring continuous work we offer two different spare part **KITS** – **INTERMEDIATE SERVICE KIT** includes most often wear parts and **MAJOR SERVICE KIT** includes parts to carry on major overhaul.

	Pos.	Description	Q-ty
INTERMEDIATE SERVICE KIT FP/FH 25/40	16	O-Ring valve seat	2/4 ¹
	19	Valve seat	2/4 ¹
	20	Valve ball	2/4 ¹
	34	Muffler	2
	24	O-Ring Flange	2/4 ¹
	52	O-ring Discharge ²	1/2 ¹

	Pos.	Description	Q-ty
MAJOR SERVICE KIT FP/FH 25/40	4	Cylinder Pneumatic	1
	7	Piston Hydraulic	1/2 ¹
	9	Hose bush suction (only at PP pumps required)	1/2 ¹
	12	Hose bush discharge (only at PP pumps required)	1/2 ¹
	18	Tubular diaphragm (Hose)	1/2 ¹
	19	Valve seat	2/4 ¹
	20	Valve ball	2/4 ¹
	30	Sensor	2
	32	Quick exhaust valve	2
	34	Muffler	2
	99	Hydraulic Liquid ³	
	D	Sealing set complete ⁴	-

1 - For pump size 40

2 - Only PP pumps

3 - 3 liters for FP/FH 25; 6 liters for FP/FH 40

4 - Designated for proper type of pump (FP or FH).

4. SPARE PARTS

	Pos.	Description	Q-ty
INTERMEDIATE SERVICE KIT FP/FH 50/80	16	O-Ring valve seat	4
	19	Valve seat suction	2
	46	Valve seat discharge	2
	20	Valve ball	4
	34	Muffler	2
	24	O-Ring Flange	4
	52	O-ring Discharge ¹	2

	Pos.	Description	Q-ty
MAJOR SERVICE KIT FP/FH 50/80	4	Cylinder Pneumatic	1
	7	Piston Hydraulic	2
	9	Hose bush suction (only at PP pumps required)	2
	12	Hose bush discharge (only at PP pumps required)	2
	18	Tubular diaphragm (Hose)	2
	19	Valve seat suction	2
	46	Valve seat discharge	2
	20	Valve ball	4
	30	Sensor	2
	32	Quick exhaust valve	2
	34	Muffler	2
	99	Hydraulic Liquid ²	*
	D	Sealing set complete ³	-

1 - Only PP pumps

2 - 30 liters for FP/FH 50/80

3 - Designated for proper type of pump (FP or FH).

4.8. How to order parts

When ordering spare parts for FP/FH series pumps, please let us know what the model number and serial number from the pump name plate is. Then just indicate the part numbers from the spare parts list and quantity of each item. Please note that pump codification has been updated. If you are going to place an order for spare parts for pump manufactured before 07 2019 please review actual spare parts drawings and list.

4. SPARE PARTS

4.9. Pump code

The model number on the pump and on the front page of this instruction manual tells the pump size and materials of the pump.

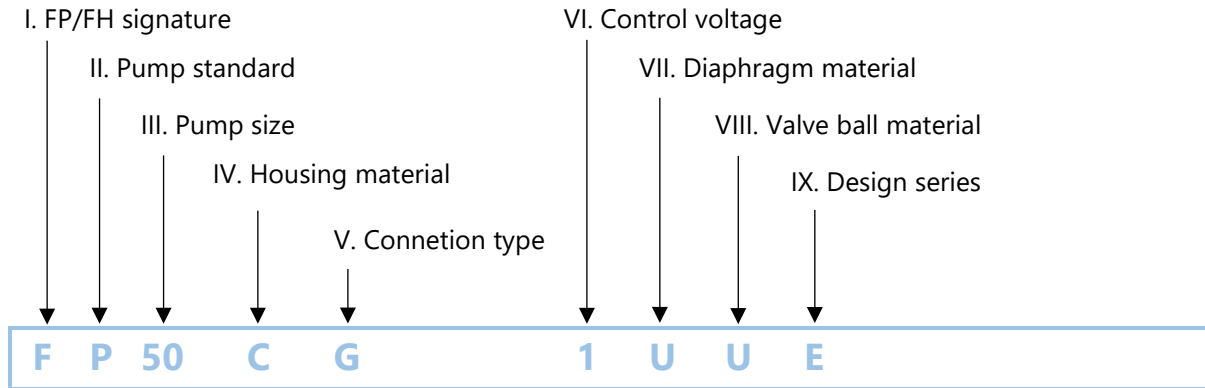

- | | |
|--|---|
| <p>I. F = Steinle High Pressure Filterpress pump</p> <p>II. P = Standard pump - 1:2,4 pressure ratio
H = High pressure pump - 1:3,3 pressure ratio</p> <p>III. Pump size
25, 40, 50 or 80</p> <p>IV. Housing material:
C = Mild steel
S = AISI 316L Stainless steel
P = Polypropylene (PP) (up to max 16 bar)</p> <p>V. Connection type:
G = BSP female thread (G 1.1/2" std. on Fx25 and Fx40 metal pumps)
F = Flange acc. to EN 1092-1 Type 11 Face B1 (std. on Fx50, Fx80 and all PP pumps)
A = Flange acc. to ANSI 16.5B Class 150
J = Flange acc. to JIS</p> | <p>VI. Control voltage
1 = 24 VDC (standard)
2 = 220/240 VAC 50 Hz
3 = 110/130 VAC 50/60 Hz</p> <p>VII. Diaphragm material
S = Superflex (standard)
U = Polyurethane (PU)</p> <p>VIII. Valve ball material
N = NBR
U = Polyurethane (PU)
B = PTFE-TFM
P = PE1000
C = Neoprene (CR) with steel core</p> <p>IX. Design series
E = Last standard manufactured at Steinle
F = Current standard - manufactured at Tapflo</p> |
|--|---|

5. DATA

5. DATA

5.1. Capacity curves

The performance curves are based on water at 20°C. Other circumstances might change the performance. See below how the capacity will change at different viscosities and suction lifts.

Example FP 40:

With an existing pressure of 5 bar in compressed air supply, the pump delivers 3,5 m³/h at approximately 4 bar. Air consumption will be 0,65 m³/min in this case.

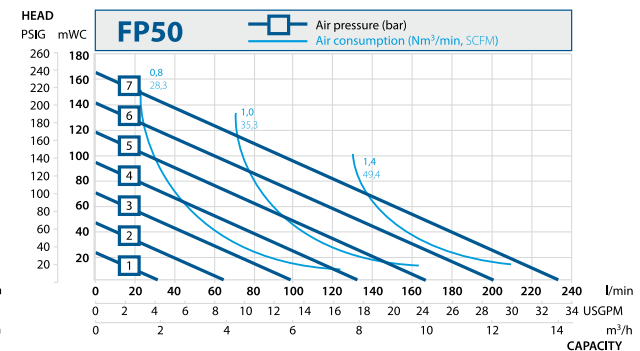
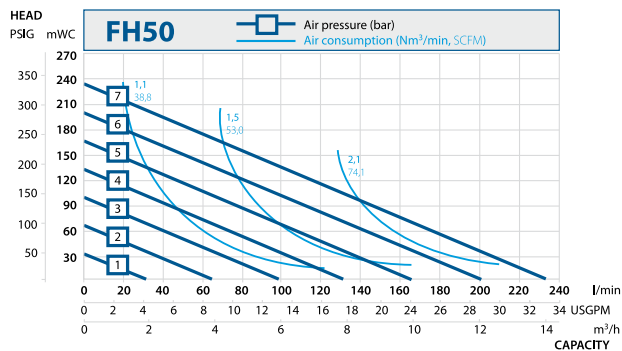
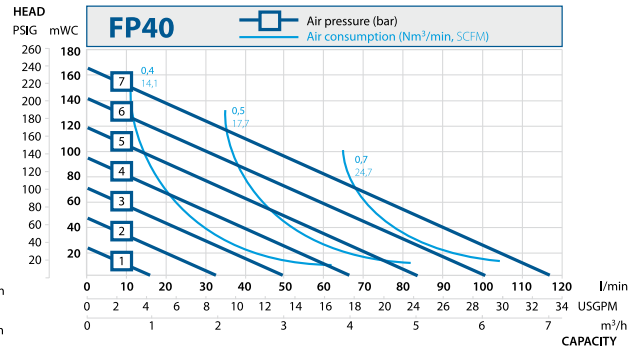
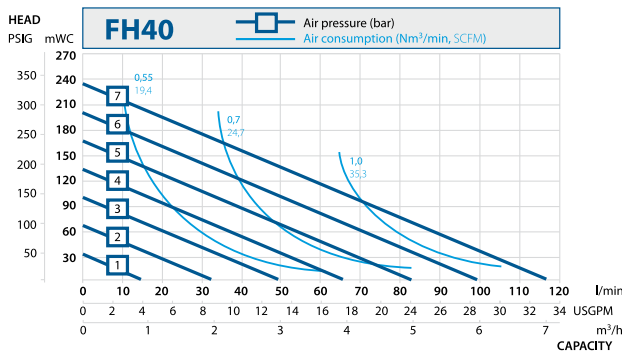
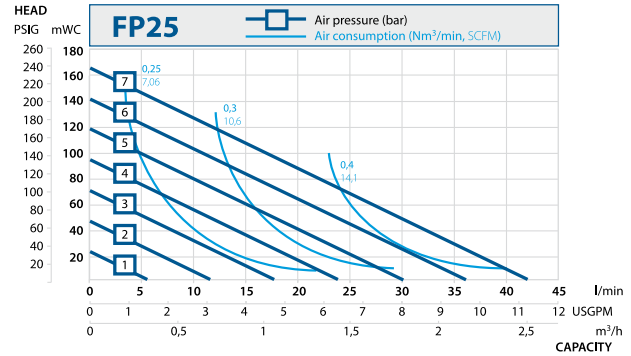
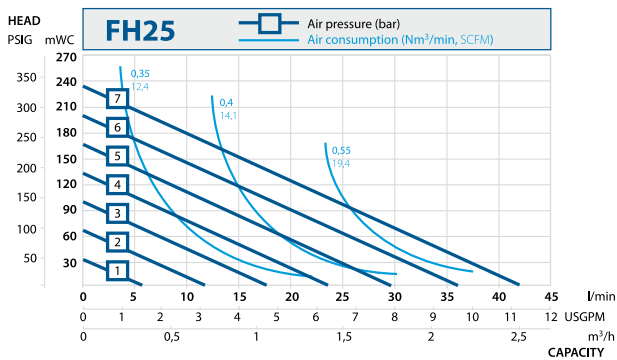

5. DATA

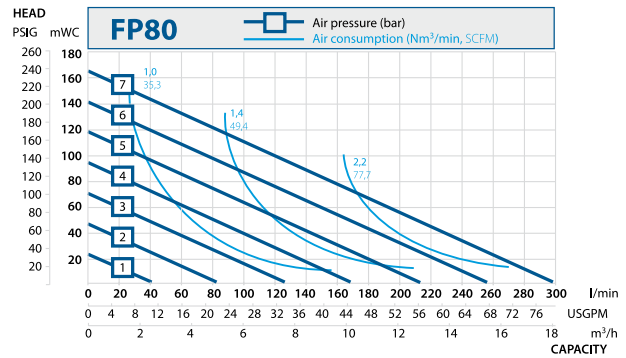
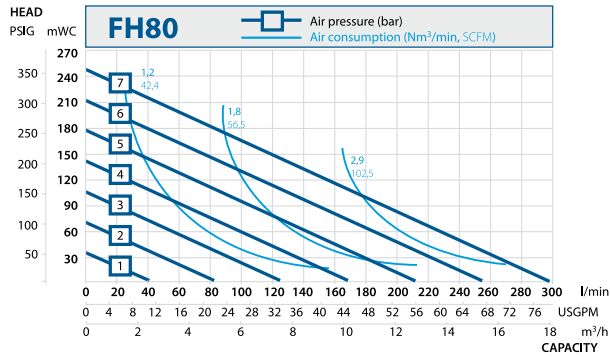

5.2. Capacity changes

Capacity changes at different suction lifts

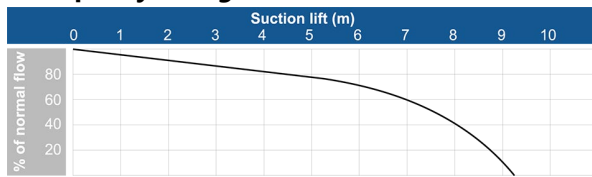

Capacity changes at different viscosities

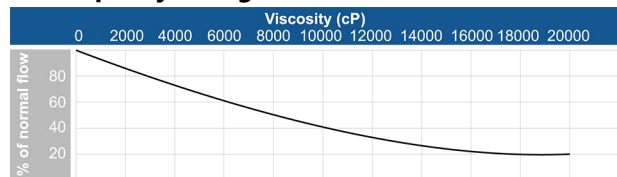

5.3. Dimensions

Dimensions in mm (where other is not indicated)

Dimensions in inch (where other is not indicated)

General dimensions only, ask us for detailed drawings. Changes reserved without notice.

Dimensions	Pump size			
	FP/FH 25	FP/FH 40	FP/FH 50	FP/FH 80
a	780 / 30.70	941 / 37.05	1445 / 56.89	1445 / 56.89
b	730 / 28.74	1001 / 39.41	1525 / 60.04	1525 / 60.04
c	380 / 14.96	380 / 14.96	480 / 18.90	480 / 18.90
d	440 / 17.32	440 / 17.32	540 / 21.26	540 / 21.26
e	1234 / 48.58	1234 / 48.58	1787 / 70.35	1804 / 71.02
f	1159 / 45.63	1159 / 45.63	1704 / 67.09	1704 / 67.09
g	1183 / 46.57	1183 / 46.57	1735 / 68.31	1749 / 68.86
h	102 / 4.02	102 / 4.02	112 / 4.41	144 / 5.67
i	806 / 31.73	806 / 31.73	860 / 33.86	860 / 33.86
k	249 / 9.80	249 / 9.80	273 / 10.75	273 / 10.75
m	133 / 5.24	133 / 5.24	196 / 7.72	196 / 7.72
DN	40	40	50	80

5. DATA

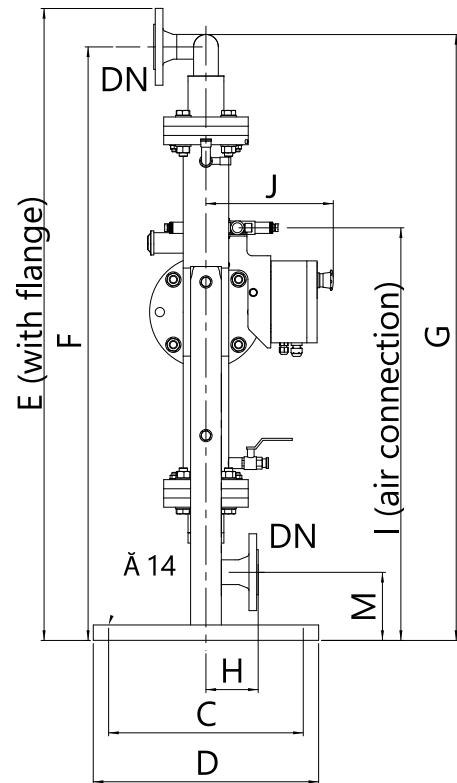
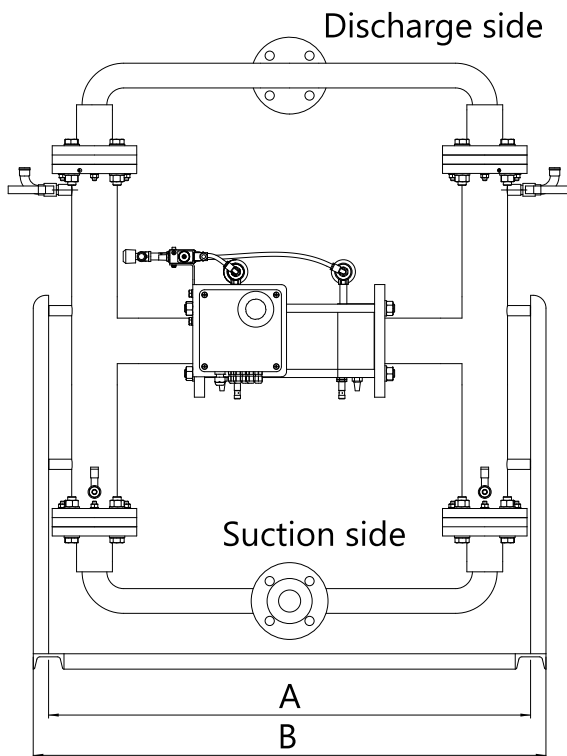
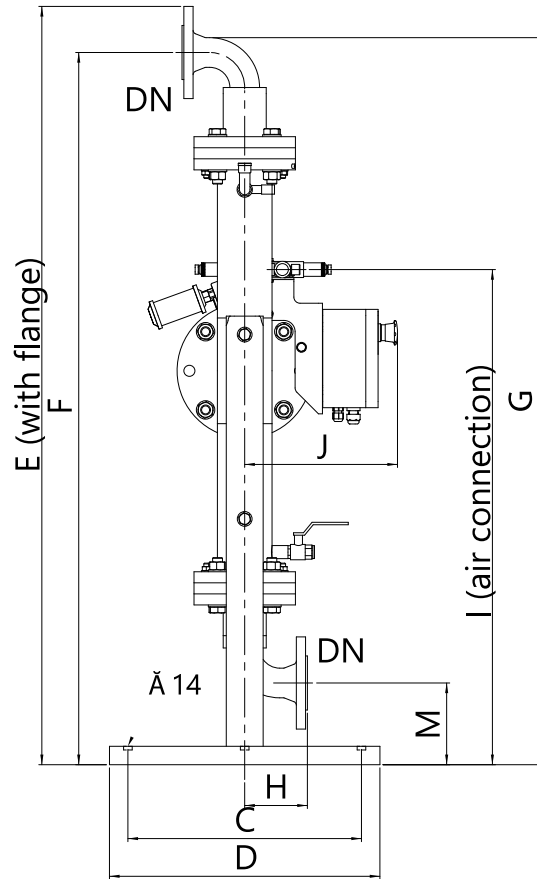
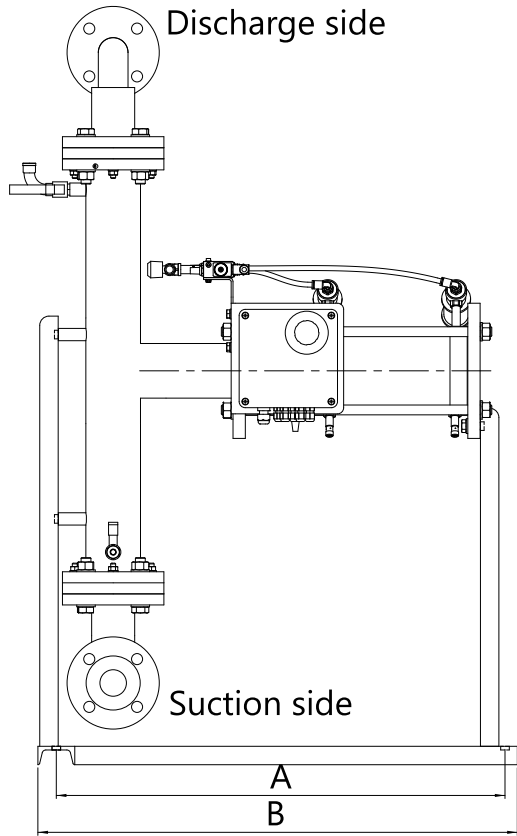

5. DATA

5.4. Technical data

TECHNICAL DATA	PUMP SIZE			
	FP/FH 25	FP/FH 40	FP/FH 50	FP/FH 80
Max capacity [m ³ /h] / [US GPM]	2.5 / 11	7 / 31	14 / 62	18 / 79
Max discharge pressure [bar] / [psi]	16 / 232 (FP) ; 24 / 348 (FH)			
Pressure transmission	1 : 2.4 (FP) ; 1 : 3.3 (FH)			
Max air pressure [bar] / [psi]	7 / 102			
Displacement* [l] / [cu in]	0.7 / 42.7		2 / 122	
Max suction lift dry [m] / [Ft]	2 / 6.6			
Max suction lift wet [m] / [Ft]	5 / 16.4			
Medium operating temperature:	-20 - 80°C / -4 - 176°F			
Allowable ambient temp range:	0°C - 40°C / 32 - 104°F			
Control power:	12 W required			
Protection class:	IP 65			
Max size of solids ø in [mm] / [in]	10 / 0.39	10 / 0.39	15 / 0.59	15 / 0.59
Weight [kg] / [lb]	62 / 28	90 / 41	162 / 74	188 / 85

* = each chamber

COMPONENT	MATERIAL
Housing material:	Mild Steel, SS 316, Polypropylene (up to 16 bar)
Valve balls	NBR, PU, PTFE-TFM, PE100, CR Steel core
Sealing (wetted)	NBR
Sealing (pneumatic)	PUR/NBR
Diaphragms	Superflex, PUR
Slide ring	PTFE
Housing screws, nuts	Steel – grade 8.8
Screws	A4-70
Valve seat parts, hose bush	Steel, PP, stainless steel
Exhaust silencer	Aluminium
Pneumatic cylinder	St 52
Piston pneumatic parts	PA6
Hydraulic piston	S355 / St52-3
Balance tube	PP
Mount	AISI 304L
Hydraulic liquid	Biological degradable

5. DATA

5.5. Tightening torques

Checking of the tightening torques is necessary after all periods of stoppage, when temperature variations are a factor and after all transport and maintenance of the pump. What is more for proper operation and safety the torque values should be checked frequently as part of preventive maintenance (please contact Tapflo for interval proposals).

FP25/40 CS/SS		F25/40 PP	
Position	Moment of force [Nm]	Position	Moment of force [Nm]
Top housing - manifold bolt	80	Top housing - manifold bolt	35
Bottom housing - manifold bolt	15	Bottom housing - manifold bolt	15
Housing - housing bolt	80	Housing - housing bolt	80
-	-	Manifold - manifold bolt	35

FP50/80 CS/SS		FP50/80 PP	
Position	Moment of force [Nm]	Position	Moment of force [Nm]
Top housing - manifold bolt	80	Top housing - manifold bolt	35
Bottom housing - manifold bolt	25	Bottom housing - manifold bolt	25
Housing - housing bolt	160	Housing - housing bolt	160
-	-	Manifold - manifold bolt	35

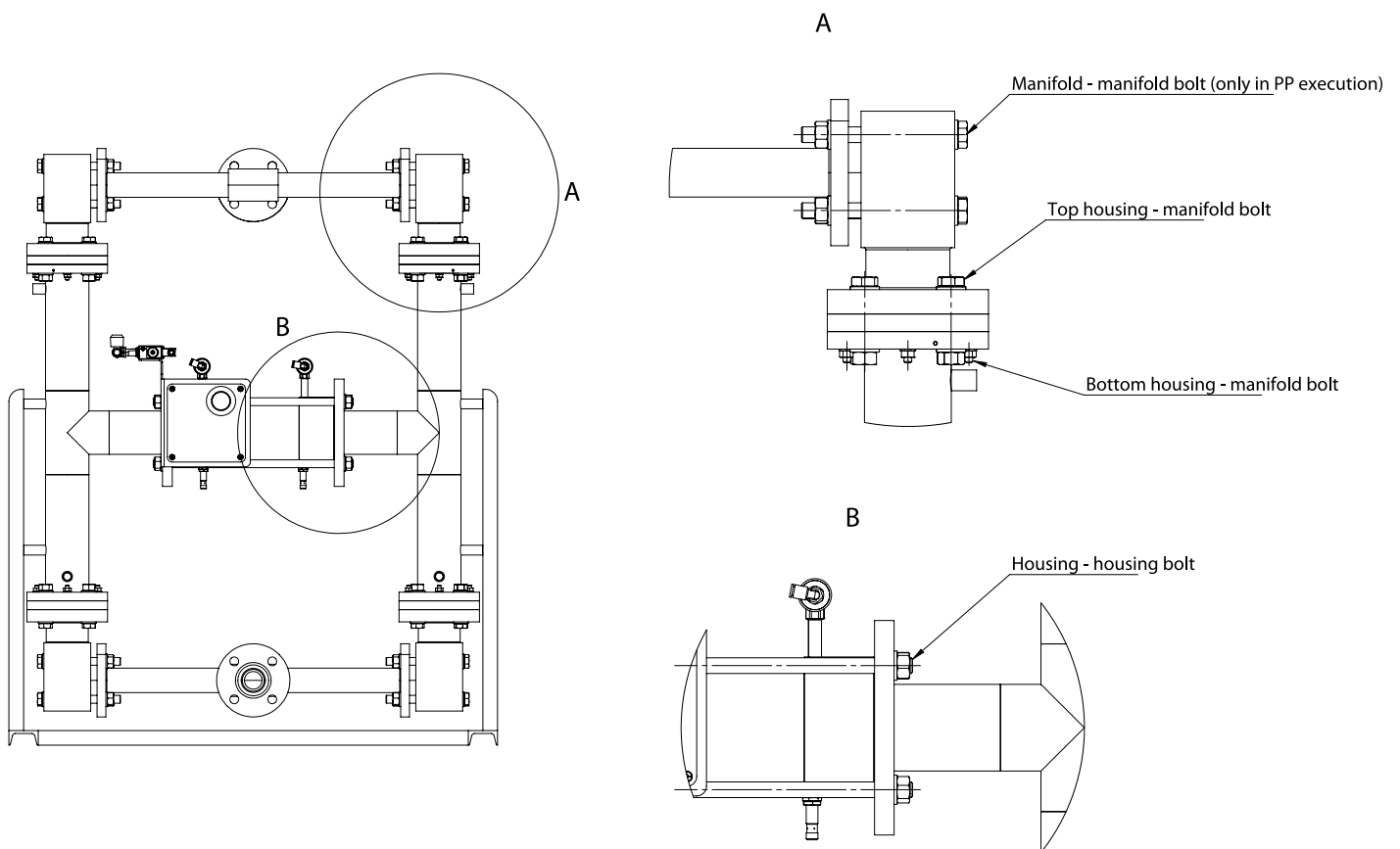

5. DATA

5.6. Permitted manifold loads

We recommend not to exceed the following loads and forces reacting on the manifolds.

FP25 CS/SS		
Direction	Load [N] (inlet/outlet)	Moment of force (inlet/outlet) [Nm]
X	60	9
Y	60	9
Z	60	9

FP80 CS/SS		
Direction	Load [N] (inlet/outlet)	Moment of force (inlet/outlet) [Nm]
X	100	14
Y	100	14
Z	100	14

FP25 PP		
Direction	Load [N] (inlet/outlet)	Moment of force (inlet/outlet) [Nm]
X	50	8
Y	50	8
Z	50	8

FP80 PP		
Direction	Load [N] (inlet/outlet)	Moment of force (inlet/outlet) [Nm]
X	90	11
Y	90	11
Z	90	11

FP40 CS/SS		
Direction	Load [N] (inlet/outlet)	Moment of force (inlet/outlet) [Nm]
X	60	9
Y	60	9
Z	60	9

FP40 PP		
Direction	Load [N] (inlet/outlet)	Moment of force (inlet/outlet) [Nm]
X	50	8
Y	50	8
Z	50	8

FP50 CS/SS		
Direction	Load [N] (inlet/outlet)	Moment of force (inlet/outlet) [Nm]
X	70	12
Y	70	12
Z	70	12

FP50 PP		
Direction	Load [N] (inlet/outlet)	Moment of force (inlet/outlet) [Nm]
X	60	10
Y	60	10
Z	60	10

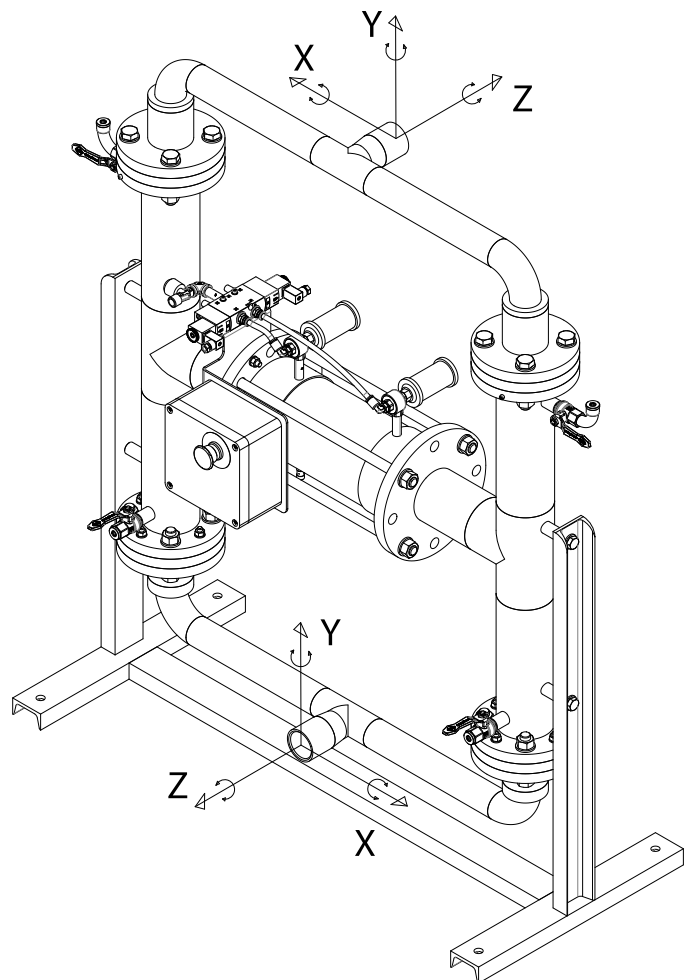

6. WARRANTY

6. WARRANTY

6.1. Warranty form

Company:	_____						
Telephone:	_____	Fax:	_____				
Address:	_____						
Country:	_____	Contact Name:	_____				
E-mail:	_____						
Delivery Date:	_____	Date of pump installation:	_____				
Pump type:	_____						
Serial No (see name plate or stamped on pump housing):	_____						
Description of the fault:	_____						

The installation:							
Liquid:	_____						
Temperature [°C]:	_____	Viscosity [cPs]:	_____	Spec grav. [kg/m ³]:	_____	pH-value:	_____
Content of particles:	_____			% of max size [mm]:	_____		
Flow [l/min]:	_____	Duty [h/day]:	_____	No of starts per day:	_____		
Discharge head [mWC]:	_____		Suction head / lift [m]:	_____			
Air pressure [bar]:	_____	Quality of the air (filter, micron, lubrication):	_____				
Other:	_____						

Place for sketch of installation:							

7. WARRANTY

6.2. Returning parts

When returning parts to Tapflo please follow this procedure:

- Consult Tapflo for shipping instructions.
- Cleanse or neutralize and rinse the part/pump. Make sure the part/pump is completely empty from liquid.
- Pack the return articles carefully to prevent any damage during transportation.

Goods will not be accepted unless the above procedure has been complied with.

6.3. Warranty

Tapflo warrants products under conditions as stated below for a period of not more than 5 years from installation and not more than 6 years from date of manufacturing.

1. The following terms and conditions apply to the sale of machinery, components and related services and products, of Tapflo (hereinafter "the products").
2. Tapflo (the manufacturer) warrants that:
 - a. its products are free of defects in material, design and workmanship at the time of original purchase;
 - b. its products will function in accordance with Tapflo operative manuals; Tapflo does not guarantee that the product will meet the precise needs of the Customer, except for those purposes set out in any invitation to render documents or other documents specifically made available to Tapflo before entering into this agreement;
 - c. high quality materials are used in the construction of the pumps and that machining and assembly are carried out to the highest standards.

Except as expressly stated above, Tapflo makes no warranties, express or implied, concerning the products, including all warranties of fitness for a particular purpose.

3. This warranty shall not be applicable in circumstances other than defects in material, design, and workmanship. In particular warranty shall not cover the following:
 - a. Periodic checks, maintenance, repair and replacement of parts due to normal wear and tear (seals, O-rings, rubber items, diaphragms, air valves etc.);
 - b. Damage to the product resulting from:
 - b.1. Tampering with, abuse or misuse, including but not limited to failure to use the product for its normal purposes as stated at the time of purchase or in accordance with Tapflo instructions for use and maintenance of the product, or the installation or improper ventilation or use of the product in a manner inconsistent with the technical or safety standard in force;
 - b.2. Repairs performed by non-skilled personnel or use of non-original Tapflo parts;

7. WARRANTY

b.3. Accidents or any cause beyond the control of Tapflo, including but not limited to lightning, water, fire, earthquake, and public disturbances, etc.;

4. The warrantee shall cover the replacement or repairing of any parts, which is documented faulty due to construction or assembling, with new or repaired parts free of charges delivered by Tapflo. Parts subjected to normal tear and wear shall not be covered by the warranty. Tapflo shall decide as to whether the defective or faulty part shall be replaced or repaired.
5. The warrantee of the products shall be valid for a period in accordance to the current law from the date of delivery, under the condition that notice of the alleged defect to the products or parts thereof be given to Tapflo in written within the mandatory term of 8 days from the discovery. Repair or replacement under the terms of this warranty shall not give a right to an extension to, or a new commencement of, the period of warranty.
6. Repair or replacement under the terms of this warranty shall not give a right to an extension to, or a new commencement of, the period of warranty. Repair or replacement under the terms of this warranty may be fulfilled with functionally equivalent reconditioned units. Tapflo qualified personnel shall be solely entitled to carry out repair or replacement of faulty parts after careful examination of the pump. Replaced faulty parts or components will become the property of Tapflo.
7. The products are built in accordance with standard CE normative and are tested (where applicable) by Tapflo. Approval and tests by other control authority are for the customer's account. The products shall not be considered defective in materials, design or workmanship if they need to be adapted, changed or adjusted to conform to national or local technical or safety standards in force in any country other than that for which the unit was originally designed and manufactured. This warranty shall not reimburse such adaptations, changes or adjustments, or attempt to do so, whether properly performed or not, nor any damage resulting from them, nor any adaptation, change or adjustments to upgrade the products from their normal purpose as described in the products operative manual without the prior written consent of Tapflo.
8. Installation, including electric and other connections to utility mains according to Tapflo drawings, is for the cost and responsibility of the customer, unless otherwise agreed in writing.
9. Tapflo will not be liable on any claim, whether in contract, tort, or otherwise, for any indirect, special, incidental, or consequential damages, caused to the customer or to third parties, including loss of profits, arising by any possible infringement of par. 3 above or by the customer or third parties being in the impossibility of using the products.

Steady the above, Tapflo liability to the customer or third parties from any claim, whether in contract, tort, or otherwise, shall be limited to the total amount paid by the customer for the product that caused the damages.

Sweden

Filaregatan 4 | S-442 34 Kungälv

Tel: +46 303 63390

Fax: +46 303 19916

E-mail addresses:

Commercial questions: sales@tapflo.com

Orders: order@tapflo.com

Tech support: support@tapflo.com

Tapflo products and services are available worldwide.

Tapflo is represented by own Tapflo Group Companies and carefully selected distributors assuring highest Tapflo service quality for our customers' convenience.

AUSTRALIA | AUSTRIA | AZERBAIJAN | BAHRAIN | BELGIUM | BOSNIA | BRAZIL | BULGARIA | CANADA | CHILE | CHINA | COLOMBIA | CROATIA | CZECH REPUBLIC | DENMARK | ECUADOR | EGYPT | ESTONIA | FINLAND | FRANCE | GEORGIA | GERMANY | GREECE | HONG-KONG | HUNGARY | ICELAND | INDIA | INDONESIA | IRELAND | ISRAEL | ITALY | JAPAN | JORDAN | KAZAKHSTAN | KUWAIT | LATVIA | LIBYA | LITHUANIA | MACEDONIA | MALAYSIA | MEXICO | MONTENEGRO | MOROCCO | NETHERLANDS | NEW ZEALAND | NORWAY | OMAN | PHILIPPINES | POLAND | PORTUGAL | QATAR | ROMANIA | SAUDI ARABIA | SERBIA | SINGAPORE | SLOVAKIA | SLOVENIA | SOUTH AFRICA | SOUTH KOREA | SPAIN | SWEDEN | SWITZERLAND | TAIWAN | THAILAND | TURKEY | UKRAINE | UNITED ARAB EMIRATES | UNITED KINGDOM | USA | UZBEKISTAN | VIETNAM

Tapflo Group Companies

Australia

Tapflo Oceania (Pty) Ltd.
Tel: +61 1800303633
sales@tapflo.com.au

China

Tapflo (Wuxi) Pumps Co. Ltd.
Tel: +86 51082417072
sales@tapflo.cn

Ireland

Tapflo Ireland Ltd.
Tel: +353 12011911
info@tapflo.ie

Poland

Tapflo Sp. z o.o.
Tel: +48 609 995 500
info@tapflo.pl

Spain

Tapflo Ibérica S.L.
Tel: +34 918093182
avives@tapfloiberica.es

Uzbekistan

Tapflo Uzbekistan
Tel: +998 712370940
sales@tapflo.uz

Austria

Tapflo GmbH
Tel: +43 73227292910
sales@tapflo.at

Croatia

Tapflo d.o.o.
Tel: +385 914884666
sales@tapflo.hr

Italy

Tapflo Italia S.r.l.
Tel: +39 0362306528
info@tapfloitalia.com

Qatar

Tapflo Gulf General Trading Co. L.L.C
Tel: +971 58 582 3630
sales@tapfloqulf.com

South Africa

Tapflo (Pty) Ltd.
Tel: +27 317015255
sales@tapflo.co.za

Bahrain

Tapflo Gulf General Trading Co. L.L.C
Tel: +971 58 582 3630
sales@tapfloqulf.com

Czech Republic

Tapflo s.r.o.
Tel: +420 513033920
tapflo@tapflo.cz

Japan

Tapflo Japan K.K.
Tel: +81 362403510
tapflojp@tapflo.co.jp

Romania

S.C. Tapflo Rom. S.r.l.
Tel: +40 213451255
sales@tapflo.ro

Sweden

Tapflo AB Tel: +46
(0)30314050 info@tapflo.com

Baltic States

Tapflo SIA
Tel: +371 67472205
sales@tapflo.lv

Denmark

Tapflo Danmark ApS
Tel: +45 36454600
info@tapflo.dk

Kazakhstan

Tapflo LLP
Tel: +7 727 327 83 47
sales@tapflo.kz

Saudi Arabia

Tapflo Gulf General Trading Co. L.L.C
Tel: +971 58 582 3630
sales@tapfloqulf.com

Turkey

Tapflo Makina Ltd.
Tel: +90 2164673311
sales@tapflo.com.tr

Belgium

Tapflo Benelux B.V.
Tel: +31 (0) 6 21850664
info@tapflo.nl

France

Sarl Tapflo France
Tel: +33188788240
info@tapflo.fr

Kuwait

Tapflo Gulf General Trading Co. L.L.C
Tel: +971 58 582 3630
sales@tapfloqulf.com

Serbia

Tapflo d.o.o.
Tel: +381 21445808
sales@tapflo.rs

Ukraine

Tapflo LLC
Tel: +380 442226844
sales@tapflo.ua

Bulgaria

Tapflo EOOD
Tel: +359 886 124 937
office@tapflo.bg

Hungary

Tapflo Kft.
Tel: +36 30148 8551
office@tapflo.hu

Netherlands

Tapflo Benelux B.V.
Tel: +31 (0) 6 21850664
info@tapflo.nl

Slovakia

Tapflo s.r.o.
Tel: +421 911137883
tapflo@tapflo.sk

Canada

Tapflo Canada
Tel: +1 514 409 8380
office@tapflo.ca

India

Tapflo Fluid Handling India Pvt Ltd.
Tel: +91 9028574063
enquiry@tapflo.in

Oman

Tapflo Gulf General Trading Co. L.L.C
Tel: +971 58 582 3630
sales@tapfloqulf.com

Slovenia

Tapflo d.o.o.
Tel: +386 68613474
sales@tapflo.hr

United Arab Emirates

Tapflo Gulf General Trading Co. L.L.C
Tel: +971 58 582 3630
sales@tapfloqulf.com

United Kingdom

Tapflo (UK) Ltd.
Tel: +44 2380252325
sales@tapflo pumps.co.uk



If your country is not listed please visit www.tapflo.com/en/contact