

English

MODEL

TPUK-GU4X-_T

topflo[®]
pumps & systems



Operation & Maintenance Manual

Guardian system Mk4.1



Instructions for the installation, start-up, operation, maintenance and repair



Spare parts



Read this instruction manual carefully before you install and operate this system!

CONTENTS

| Page | Section | Sub-section |
|------|-----------------------------|--------------------------|
| 1 | Declarations of Conformity | |
| 3 | Guardian Mk4.1 | Introduction |
| | | Warning symbols |
| | | Receiving inspection |
| | | Storage |
| 4 | | Mounting |
| | | Electrical connections |
| | | Air connections |
| | | Air preparation |
| | | Air pressure |
| | | Health & safety |
| | | Protection |
| | | Explosive environments |
| 5 | Principle of operation | |
| 6 | Function plate | |
| 7 | Set point adjustment | |
| 8 | Remote reset | |
| 9 | Alarm output | |
| 10 | Improved repeatability mode | |
| 11 | Barrier & Stop (BARR) | Principle of operation |
| | | Recommended installation |
| | | Set point adjustment |
| | | Operation |
| | | Trouble shooting |
| 18 | Dry-run & Stop (DR&S) | Principle of operation |
| | | Recommended installation |
| | | Set point adjustment |
| | | Operation |
| | | Trouble shooting |
| 23 | Dead-head & Stop (DH&S) | Principle of operation |
| | | Recommended installation |
| | | Set point adjustment |
| | | Operation |
| | | Trouble shooting |
| 29 | Dead-head & Restart (DH&R) | Principle of operation |
| | | Recommended installation |
| | | Set point adjustment |
| | | Operation |
| | | Trouble shooting |
| 35 | Specifications | Dimensions |
| | | Connections |
| | | Characteristics |
| | | Guardian coding |
| 37 | Maintenance | Routine inspection |
| | | Complete inspection |
| | | Tightening torques |
| | | Guardian parts |
| | | Returning parts |
| 39 | Warranty | Warranty / return form |
| | | Sketch of installation |

DECLARATIONS OF CONFORMITY

tapflo®



Victory Close
Chandlers Ford, Hants
SO53 4BU
Telephone: +44 2380 25 23 25
Fax: +44 2380 269016
Email: sales@tapflopumps.co.uk

EC Declaration of Conformity

The Machinery Directive 2006/42/EC

| | |
|---|---|
| Name and Address of the manufacturer: | Tapflo UK Limited Tapflo House Victory Close Chandler's Ford Industrial Estate Hampshire SO53 4BU UK |
| Description of Equipment: | Guardian Mk.4 |
| Models: | TPUK - GU4X – ST & TT |
| Serial No.'s: | 19-01-0001 to 29-12-1000 |
| Directives / Conformity Assessment Procedures: | The Machinery Directive (2006/42/EC) / Non Annex IV Machinery, Self declaration/Technical file |
| Technical standards and specifications: | BS EN ISO 80079-36:2016 (Non-electrical equipment for explosive atmospheres – Basic method and requirements) BS EN ISO 80079-37:2016 (Non-electrical equipment for explosive atmospheres – Non-electrical type of protection constructional safety "c", control of ignition sources "b", liquid immersion "k") |
| Declaration: | The person signing below declares that the above-named equipment fulfils all the relevant provisions of the stated directives. |
| Place of Declaration & Date: | Tapflo UK Limited, SO53 4BU, UK 05/03/2019 |
| Signed: |  |
| Printed Name of Authorised Signatory: | Mr. M. Barnes |
| Position in Company: | CEO |

TPUK-GU4X-ST / TPUK-GU4X-TT

E-mail
sales@tapflopumps.co.uk

VAT reg. No.
699169752

DECLARATIONS OF CONFORMITY



Victory Close
Chandlers Ford, Hants
SO53 4BU
Telephone: +44 2380 25 23 25
Fax: +44 2380 269016
Email: sales@tapflopumps.co.uk

EU Declaration of Conformity

Directive 2014/34/EU

“Potentially explosive atmospheres”

Tapflo (UK) Ltd declares that the following equipment:

Product name: Guardian Mk.4
Models: TPUK - GU4X - ST

Complies with the requirements of the Directive 2014/34/EU exclusively in their NON-ELECTRICAL part, as referred to in this declaration, intended for operation in potentially explosive atmospheres according to:

Equipment Group: IIG (Gas) / IID (Dust)
Category: 2
Apparatus Group: IIB, IIIC
Maximum surface temperature: T135°C (T4)
Equipment Protection Level: Gb (Gas) / Db (Dust)

Standards & Directives: EN ISO 80079-36:2016
EN ISO 80079-37:2016
The Machinery Directive (2006/42/EC) / Non-Annex IV Machinery, Self-declaration / Technical File.

Products are marked additionally with the following characteristics:

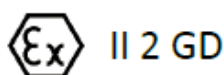

Ex h IIB T4 Gb Ex h IIIC T135°C Db

Technical file reference: 19XT023
Manufacturer: Tapflo (UK) Ltd, SO53 4BU, England.
Notified body: Full details of the conformity assessment procedure can be found in the technical reference file “TPUK-GU4X-SS Assessment Report”. In accordance with the requirements of the directive 2014/34/EU, a copy of this file has been archived with the following notified body:

Tapflo UK, March 18th 2019
Authorised / Approved by;

Mick Barnes, CEO, Tapflo (UK) Ltd

CSA Products
Unit 6, Hawarden Industrial Park
Hawarden, Deeside

TPUK-GU4X-ST

E-mail
sales@tapflopumps.co.uk

VAT reg. No.
899189752

GUARDIAN MK.4

Introduction

Tapflo (UK) pump control systems are designed to offer simple solutions for industrial pumping applications. The systems work in harmony with each pump application utilising similar means of power and methods of construction to give safe, simple and reliable use.

With proper installation, set-up and maintenance Tapflo (UK) systems give efficient and trouble free operation. This manual will familiarize operators with detailed information about installing, operating and maintenance of the system.

Warning symbols

The following warning symbols are present in this instruction manual. The warning information should be observed when either of these symbols is present.



This symbol highlights all safety instructions in this manual where danger to persons may occur. Observe these instructions carefully and proceed with the utmost caution in these situations. Inform all users of all safety instructions. In addition to the instructions in this manual, the general safety and accident prevention regulations must be observed.



This symbol highlights points in the instruction manual of particular importance for compliance with regulations and directives, for correct work flow and the prevention of damage to, or destruction of the system or its associate equipment.



This symbol signals possible danger caused by the presence of electric fields or live wires.

Receiving inspection

Although every precaution is taken when packing and shipping, please carefully check goods on receipt, ensuring all parts listed on the packing note are accounted for. Report any damage or shortages to the delivery company and Tapflo (UK) within 24 hours of receipt.

Storage



If the equipment is to be stored prior to installation, place in a clean dry location ensuring it is not exposed to extreme temperature or humidity, ideally in original packaging to prevent contaminates entering the system.

GUARDIAN MK.4

Mounting



Tapflo (UK) systems will operate properly without being mounted unless otherwise stated. If the system is to be mounted please ensure the surface is suitable for the load detailed in the specifications and appropriate to the system and application.

Electrical connections



The system must be installed by suitably trained personnel in accordance with the prevailing code of practice. Efficient installation, inspection and maintenance of the system is essential.

Air connections



Ensure all connections observe the specifications of the system, failure to observe this could result in damage to the system and danger to personnel.

Air preparation



All Tapflo (UK) systems are designed to run on clean, dry air, lubrication is not recommended. Maximum pressure is 7 bar (G) unless otherwise stated. An inline filter of 5 micron or finer is recommended to preserve the life of the system.

Air pressure



The maximum pressure specified in the data section of this manual must not be exceeded. Higher pressures can cause damage and may cause injury to personnel.

Health and Safety



Systems must be installed according to local and national safety rules. The system must be suitable for the application. Failure to do so could result in poor performance and a risk to plant and personnel. Consult Tapflo (UK) if in doubt.

Protection



In the interest of health and safety it is essential to wear appropriate PPE when operating and/or working in the vicinity of the application.

Explosive environments



Not all Tapflo (UK) Ltd systems are certified for use in explosive environments. Consult Tapflo (UK) for further information. Incorrect installation or use may cause injury or death to personnel in the vicinity of the installation!

GUARDIAN MK.4

Principle of operation

The Guardian is an energy conservation device designed to protect an air operated double diaphragm (AODD) pump from operating in an inefficient manner that uses unnecessary energy and reduces the life of its parts.

The Guardian is a fully pneumatic, chemically inert pressure trip with integral latching output control valve with the following features

- Fully pneumatic
- Floating PTFE diaphragm
- 316L stainless steel, PTFE (conductive) or Aluminum wetted parts
- Pilot output to control the associate pump
- Integral reset button
- Integral visual indicator
- Pneumatic alarm output
- External reset from solenoid valve
- Mounting bracket

The Guardian monitors pressure, changing it's output if the monitored pressure rises above or falls below the set point of the Guardian (dependant on configuration), controlling the associate pump accordingly for the following applications

- Dry-Run & Stop (DR&S)
- Dead-Head & Stop (DH&S)
- Dead-Head & Restart (DH&R)
- Barrier pump monitoring and control (BARR)

GUARDIAN MK.4

Function plate

The Guardian Mk.4 is user configurable and must be configured to the desired mode prior to use. Check the configuration of the function plate as shown in Fig.GEN-01 in conjunction with the associate table below.

To reconfigure undo the 4x retaining screws and rotate the plate to the correct orientation and refit, being careful to ensure the retained seals remain in place

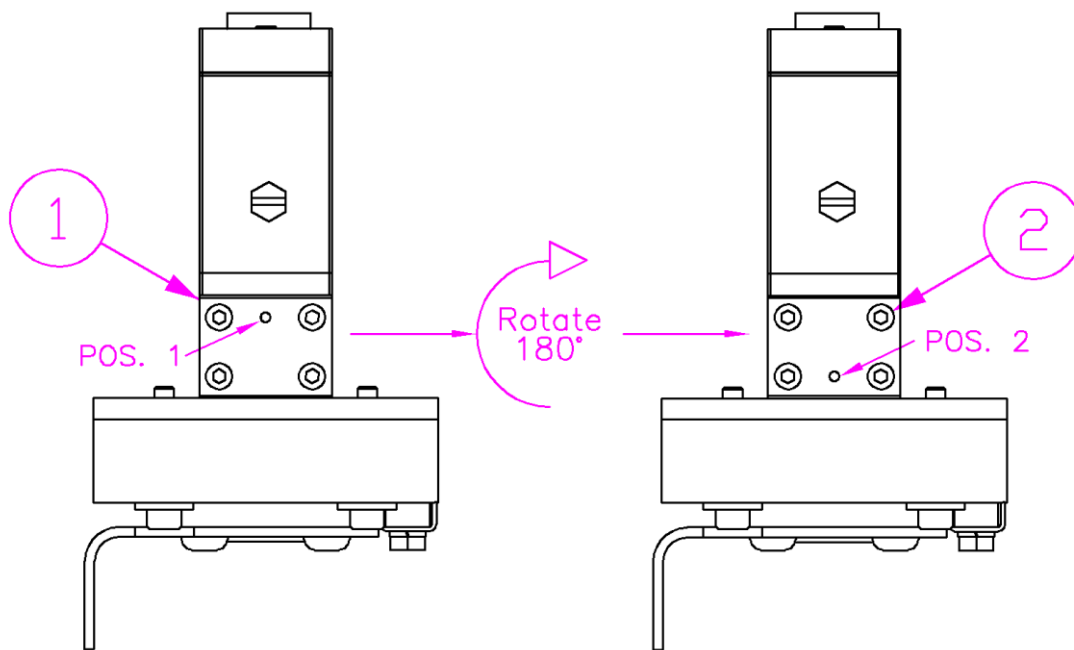

Fig.GEN-01

| | |
|---|-----------------------|
| 1 | Function plate |
| 2 | Retaining screws (x4) |

| Position | Function | Mode |
|----------|-----------------------|------------|
| POS. 1 | Falling pressure trip | DR&S, DH&R |
| POS. 2 | Rising pressure trip | BARR, DH&S |

GUARDIAN MK.4

Set point adjustment

The Guardian must be adjusted to the correct set point to ensure proper operation. Follow the instructions detailed in the application specific sections of this manual.

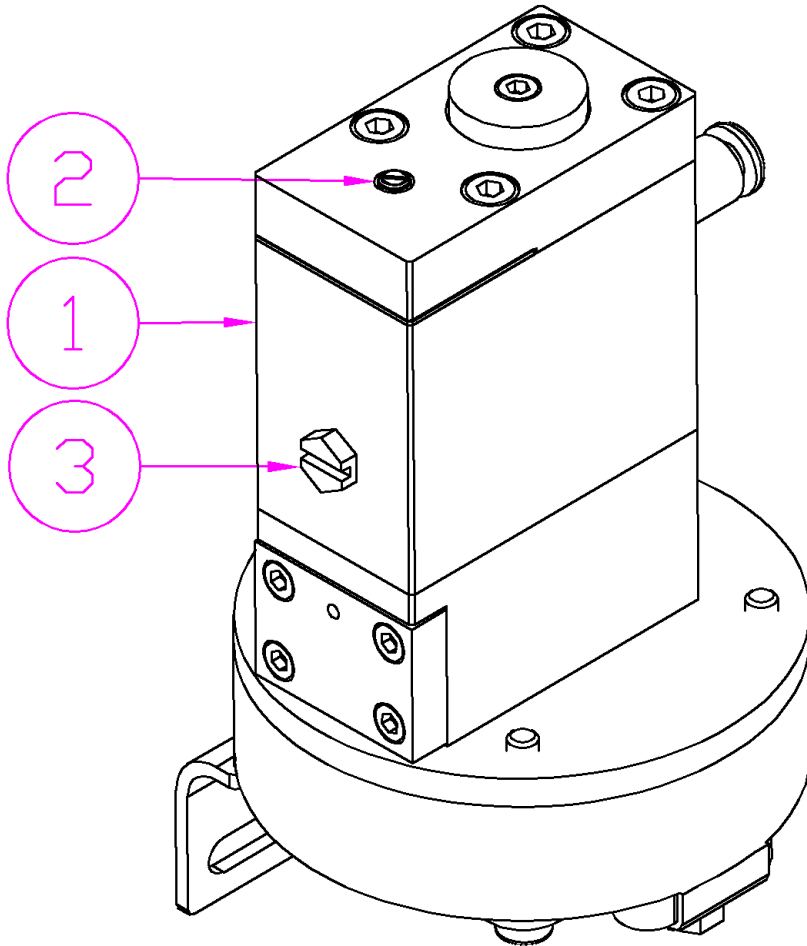

Fig.GEN-02

| | |
|---|---|
| 1 | Guardian Mk.4 |
| 2 | Set point adjustment screw |
| 3 | Set point output connection (supplied plugged M5) |

GUARDIAN MK.4

Remote Reset

The Guardian Mk.4 has a remote reset connection that enables the Guardian to be reset by an external pneumatic signal. This input is applicable to Barrier, Dry-run & Stop, and Dead-head & Stop modes only.

To use the remote reset facility, see Fig.GEN-03

- Install a 4mm to M5 push fit connection into the Reset I/P connection.
- Connect a 3/2 NC valve to the reset I/P connection
- Valve could be manual or solenoid operated and only need be a small orifice M5 size valve.
- The reset signal will need to mimic that of the reset button, see operation sections of application specific sections later in this manual.

For full piping arrangements see application specific sections of this manual.

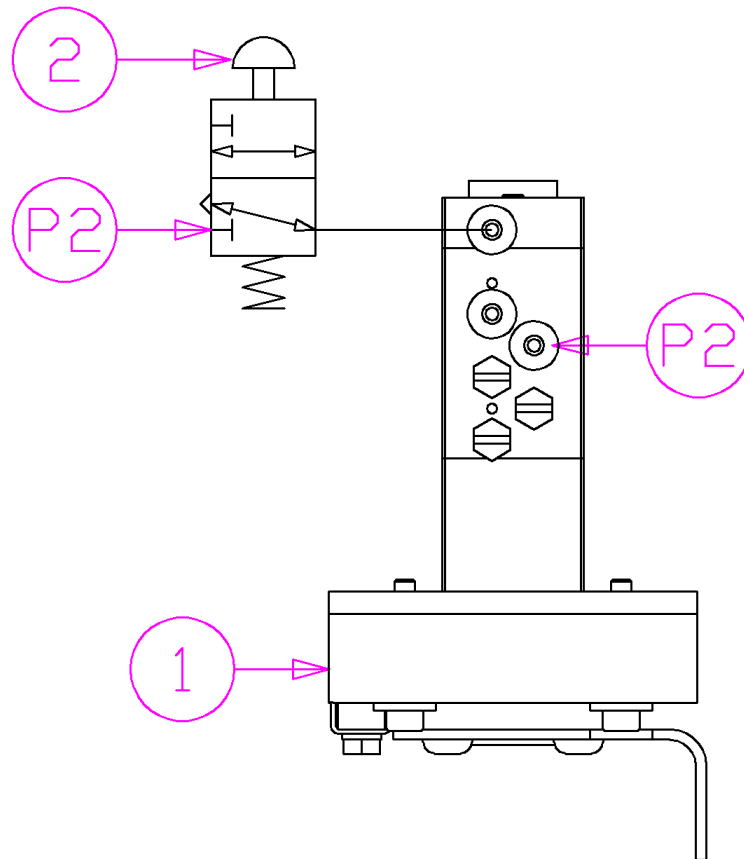

Fig.GEN-03

| | |
|----|--|
| 1 | Guardian Mk.4 |
| 2 | 3/2 NC valve Shown as push button/spring, could also be solenoid/spring |
| P2 | Air in 5-8 bar |

GUARDIAN MK.4

Alarm O/P

The Guardian Mk.4 has a pneumatic alarm output that can be used to signal a variety of indicators such as visual, audible or electrical (VFC) that in turn can be fed back into a control system such as a PLC.

This output is applicable to Barrier, Dry-run & Stop, and Dead-head & Stop modes only.

To use the Alarm O/P facility, see Fig.GEN-04

- Remove the M5 plug and install a 4mm to M5 push fit connection into the Alarm O/P connection Fig.GEN-04 (2).
- Connect any of the output options as shown in Fig.GEN-04 (4,5,6 or 7).
- The Alarm O/P is active if the guardian is set and the visual indicator is raised.

For full piping arrangements see application specific sections of this manual.

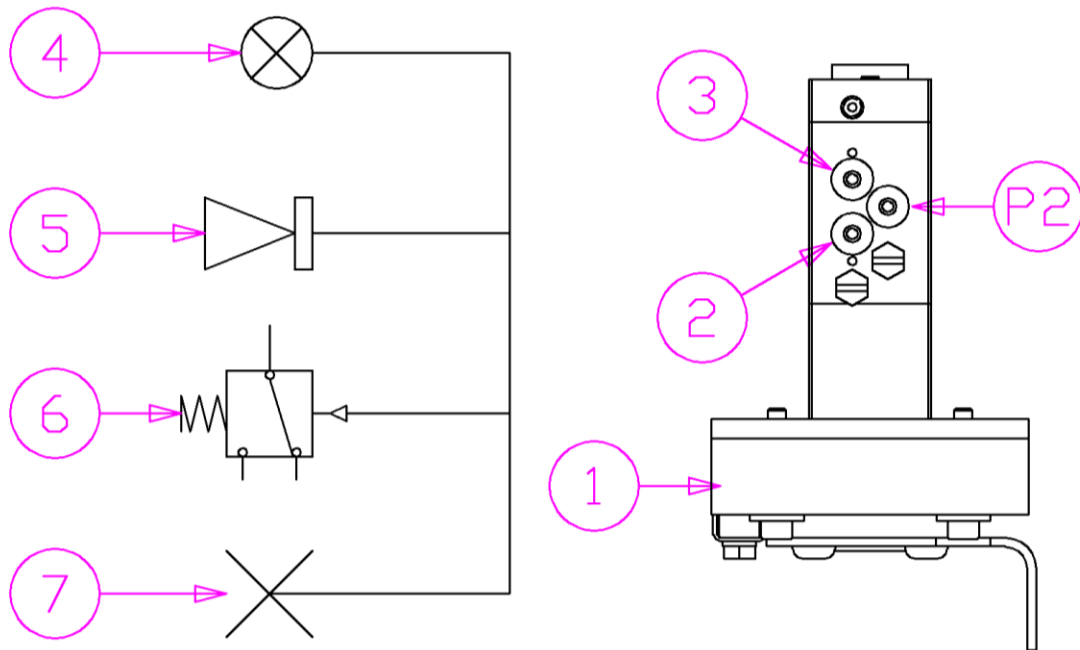

Fig.GEN-04

| | |
|----|---|
| 1 | Guardian Mk.4 |
| 2 | Alarm O/P |
| 3 | Valve O/P |
| 4 | Pneumatic visual indicator |
| 5 | Audible alarm (Such as TPUK-PA or TPUK-PAM) |
| 6 | Volt free contacts (Such as TPUK-VFC) |
| 7 | Plugged (standard) |
| P2 | Air in 5-8 bar |

GUARDIAN MK.4

Improved repeatability mode

The Guardian Mk.4 includes an improved repeatability set-point feature that prevents set point drift over time by adding the optional precision bleed fitting to the B port. This prevents the inbuilt set point regulator from drifting.

How to fit the precision bleed:

- The precision bleed is fitted in the B port as per Fig.GEN-05.



CAUTION:

Ensure the Guardian is isolated from the compressed air supply prior to removal or assembly of fittings.

- Remove the M5 plug fitted in the B port and replace with the precision bleed fitting.
- Once fitted, the set point will need to be reset as per the application specific instructions in the manual.

For full piping arrangements see application specific sections of this manual.

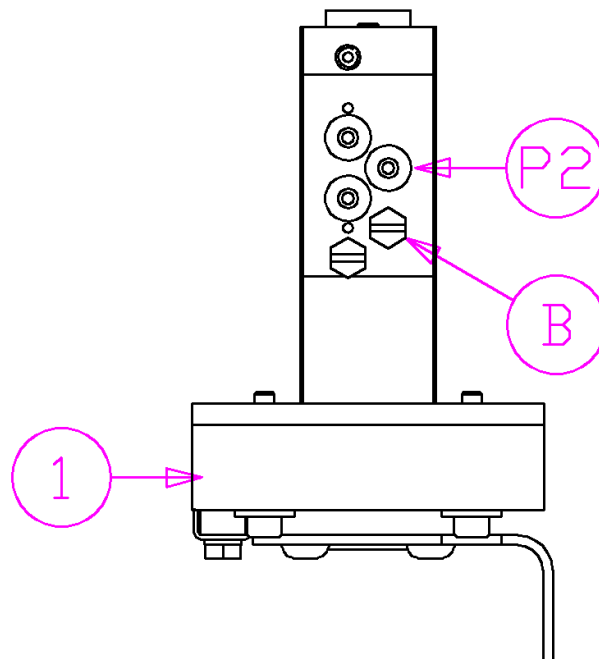

Fig.GEN-05

| | |
|----|------------------------------------|
| 1 | Guardian Mk.4 |
| B | Precision bleed (supplied plugged) |
| P2 | Air in 5-8 bar |



CAUTION:

Only manufacturer approved fittings can be used in the precision bleed port.

GUARDIAN MK.4

BARRIER & STOP (BARR)

GUARDIAN MK.4

Principle of operation

Barrier or containment AODD pumps typically contain an additional set of diaphragms used to back-up the primary diaphragms.

In the event of a breach in the primary diaphragms the back up diaphragms prevent the pumped media from being spilled from the exhaust of the AODD pump (typical failure), which could pose significant risk to plant and personnel near by.

Typically no additional system is used to determine if a breach has occurred and the fault goes unnoticed, contaminating the media with incompatible materials, and eventually the back up diaphragms breach and a spill occurs, defeating the principle of the pump.

The Guardian monitors the pressure in the voids between the primary and back up diaphragms of the AODD pump, stopping the AODD pump if the pressure in the voids increases above the set point, preventing the spill and containing the leak in it's media compatible chamber.

Fig. BARR-01 shows a graph of time against pressure showing barrier breach and stop principal

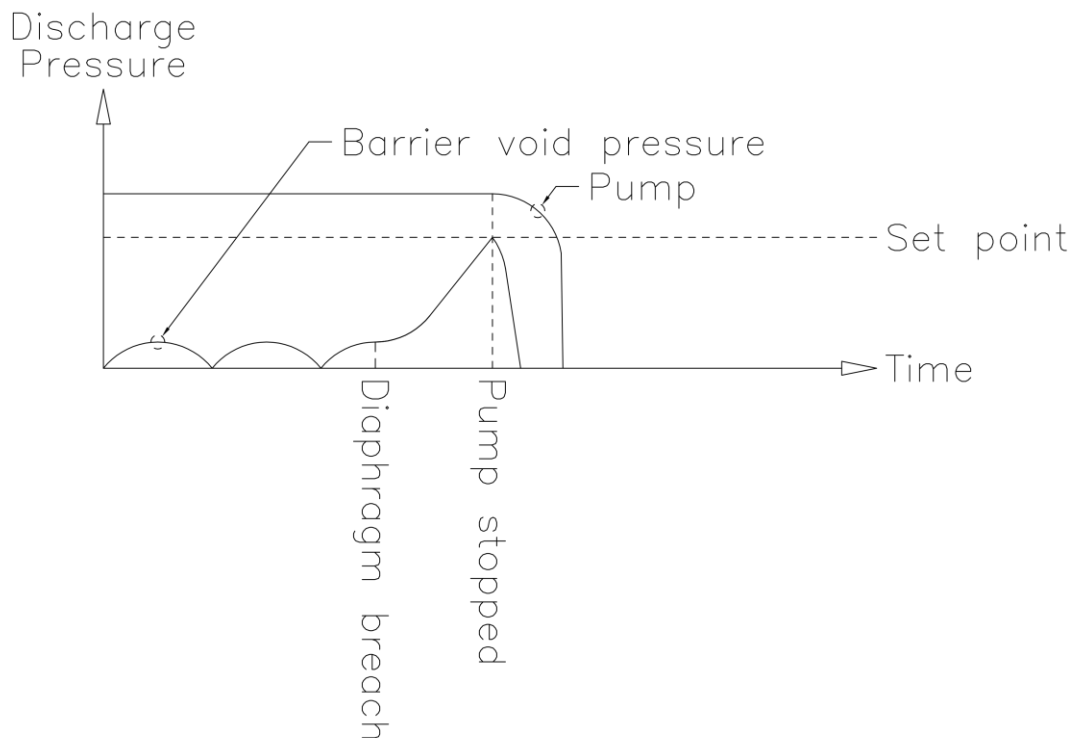

Fig. BARR-01

GUARDIAN MK.4

Recommended installation

The Guardian should be installed as per Fig. BARR-02. The media connection can be directly connected with rigid pipe work using double ferrule compression fittings, or placed independently with a flexible hose between the pump and Guardian. Ensure the pipe work is appropriately selected for the media and is suitable for the maximum pressure under breach conditions. Ensure the Guardian does not cause any tensions or strain on the pump or mounting. The Guardian must have an air supply of at least 1 bar greater than the required set point.

- **Function plate must be in Pos.2 (see page 6).**
- Media connection is connected to the barrier void ports.
- The void ports should be linked as shown in Fig. BARR-02 (4)
- P2 Air supply is connected to a filtered and regulated compressed air source of 5-8 bar.
- 'Valve O/P' output pilots an external pilot valve, sized appropriately for the pumps air inlet, such as a Tapflo TPUK-BV. Fig.BARR-2 (3)
- 'Alarm O/P' can be connected to a variety of indicators or plugged if not used (see Alarm O/P section of this manual).
- For ATEX applications, Guardian must be bonded using the earth tag.

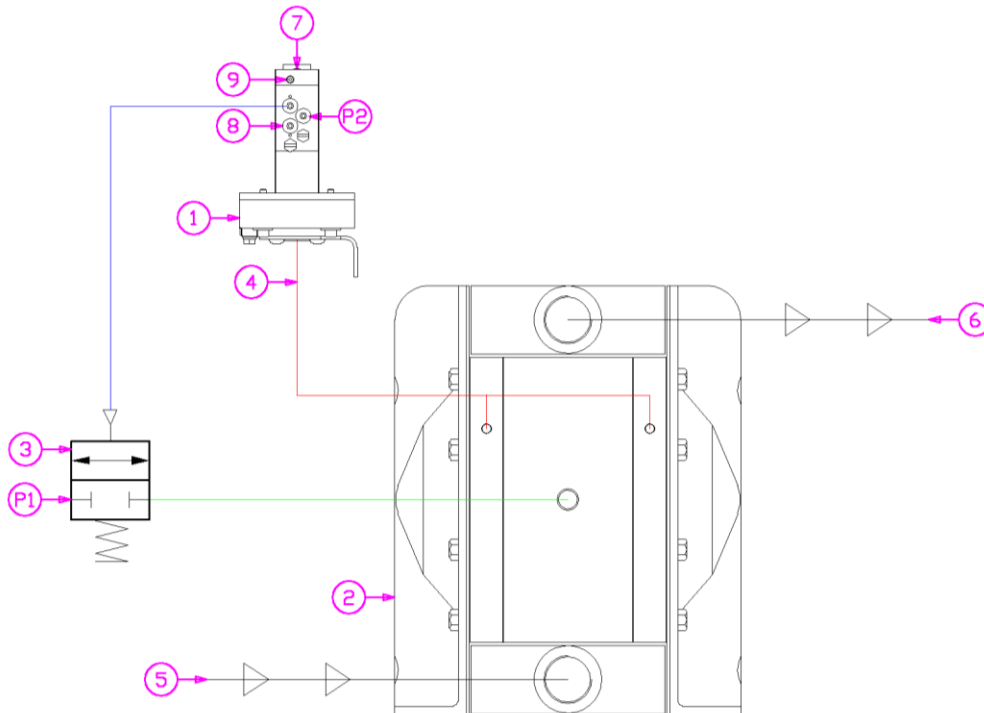

Fig. BARR-02. Barrier and stop installation circuit diagram

| | | | |
|----|--|----|-------------------------------|
| P1 | Pump air supply | P2 | Guardian air supply 5-8 bar |
| 1 | Guardian | 2 | Barrier pump (representation) |
| 3 | Pilot valve | 4 | Barrier connection |
| 5 | Pump suction | 6 | Pump discharge |
| 7 | Reset button/visual indicator | 8 | Alarm O/P connection |
| 9 | Reset I/P connection (see page 7 for more details) | | |

GUARDIAN MK.4

Set point adjustment

The Guardian's set point must be set to the desired trip pressure. There are three ways to set the Guardian's set point; Representative, Direct or Calculated. To adjust the set point you will require a small flat bladed screwdriver.

Representative

This method of set up adjusts the Guardian to the application by creating the condition in-situ.

1. Using a flat bladed screwdriver adjust the set point regulator adjustment screw (Fig.GEN-01, 2) of the Guardian anti-clockwise until it turns freely.
2. Turn the air supply on.
3. Press and hold the reset button of the Guardian.
4. The pump should start and the reset button should try to extend, continue to hold it in.
5. Slowly increase the set point regulator adjustment screw (Fig.GEN-01, 2) (clockwise) until the reset button stops trying to pop out.
6. Increase the set point regulator clockwise by a further half turn.
7. The Reset button should remain in the in position and the pump can be started and stopped normally by turning the supply to the Guardian on/off, however if not (or it stops the pump erratically) increase the set point regulator clockwise in half turn increments until the pump runs consistently.
8. The set up is now complete and the system is ready for use.

Direct

This method of set up is used when the set point pressure is known. The Guardian's set point is adjusted using an external source to generate the set point pressure, such as a calibrated air pressure regulator and gauge or a pressure calibrator. This method requires the Guardian to be removed from its installed position and the calibration pressure applied directly to the media connection.

A spare fluid side can be purchased as a test rig, see maintenance section of this manual.

1. Using a flat bladed screwdriver adjust the set point regulator adjustment screw (Fig.GEN-01, 2) of the Guardian anti-clockwise until it turns freely
2. Connect the calibration pressure source to media connection.
3. Plug all other open ports, except reset.
4. Connect an air supply to air in connection.
5. Turn the air supply on.
6. Apply the required set point pressure.
7. Press and hold the reset button of the Guardian.
9. Slowly increase the set point regulator adjustment screw (Fig.GEN-01, 2) (clockwise) until the reset button stops trying to pop out.

GUARDIAN MK.4

10. Remove the set point pressure.
11. Press the Reset button and it should remain in the in position
12. Reapply the set point pressure and the reset button should automatically extend.
13. If not repeat steps 6-12.
14. The calibration is now complete and the system is ready for use.

Calculated

This method of set up is used when the set point pressure is known. The Guardian's set point is simply adjusted to a specific pressure using an external pressure gauge connected to the 'set point o/p' connection.

1. Remove the M5 plug and connect an external pressure gauge to the 'set point O/P' connection.
2. Plug all other open ports, except reset.
3. Using a flat bladed screwdriver adjust the set point regulator adjustment screw (Fig.GEN-01, 2) of the Guardian anti-clockwise until it turns freely
4. Turn the air supply on.
5. Slowly increase the set point regulator adjustment screw (Fig.GEN-01, 2) (clockwise) until the pressure gauge indicates 0.5 Bar below the required set point (i.e. 3.0 bar switching = 2.5 bar set).
6. Turn off the air supply.
7. Remove the pressure gauge, and re-install M5 plug.
8. The set up is now complete and the system is ready for use.

GUARDIAN MK.4

Operation

- To start the pump, apply compressed air to the pump and Guardian.
- The pump should continue to run until either
 1. Air to the pump and/or Guardian is interrupted.
 2. The Guardian experiences an increased pressure, above the set point, which is represented by the rest button of the Guardian being extended (see post trip actions detailed below)
- To stop the pump, interrupt the air to the pump and/or Guardian.

Post trip actions

If the Guardian trips the system must be regarded as in breach!



Thereafter the pump, Guardian and associate pipe-work should be stripped, thoroughly cleaned and neutralized, checked and maintained before being returned to service. Refer to the 'Maintenance' section of this manual for procedures to safely maintain the Guardian. Please refer to the pump manual for details on how to safely maintain the pump.



The reset button can be used momentarily as an over-ride to purge the pump prior to maintenance, utilizing the back-up diaphragms. Press and hold the reset button for the duration of the purge, the button should oppose being pressed when the pressure exceeds the set point. The over-ride function should only be used under controlled conditions.



Abuse of the reset/over-ride could result in failure of the back-up diaphragms, allowing media to escape through the pumps exhaust, causing risk to plant and personnel!



Once the system has been rebuilt the set up procedure must be completed. Refer to set point adjustment section of this manual. (Page 13).

GUARDIAN MK.4

Trouble shooting

Check the system is configured as shown in the recommended configuration then see possible solutions below. If the problem persists consult Tapflo (UK).

| Symptom | Cause | Remedy |
|---|---|--|
| System is inoperative | Pump failure. | See pump operating manual. |
| | Unstable air supply. | Check all connections and air supply. |
| Pump stops erratically | Set point is not correct. | Perform set up procedure. |
| | Air supply is not stable. | Fit air pressure regulator. |
| | Media has changed. | Perform recalibration. |
| Guardian does not work | Leaking interconnections. | Remake or replace interconnections. |
| | Guardian set for alternative application. | Check function plate position. Consult Tapflo (UK) Ltd. |
| | Incorrect configuration. | Check all connections against recommended installation. |
| | Air pressure too low. | Air pressure must be > 1bar higher than set point. |
| | Guardian tie rods loose. | Check torque is within specification. |
|  MEDIA EGRESS | Primary diaphragm breach! | Immediately stop pump, isolate and perform maintenance. |
| | Poor installation. | Remake interconnections. |
| | Guardian tie rods loose. | Check torque is within specification. |

DRY-RUN & STOP (DR&S)

**DRY-RUN & STOP
(DR&S)**

DRY-RUN & STOP (DR&S)

Principle of operation

The Guardian monitors the fluid discharge pressure of the pump, changing its output if the monitored pressure falls below the set point of the Guardian, representing a loss of media in the pump suction line, stopping the associate pump accordingly.

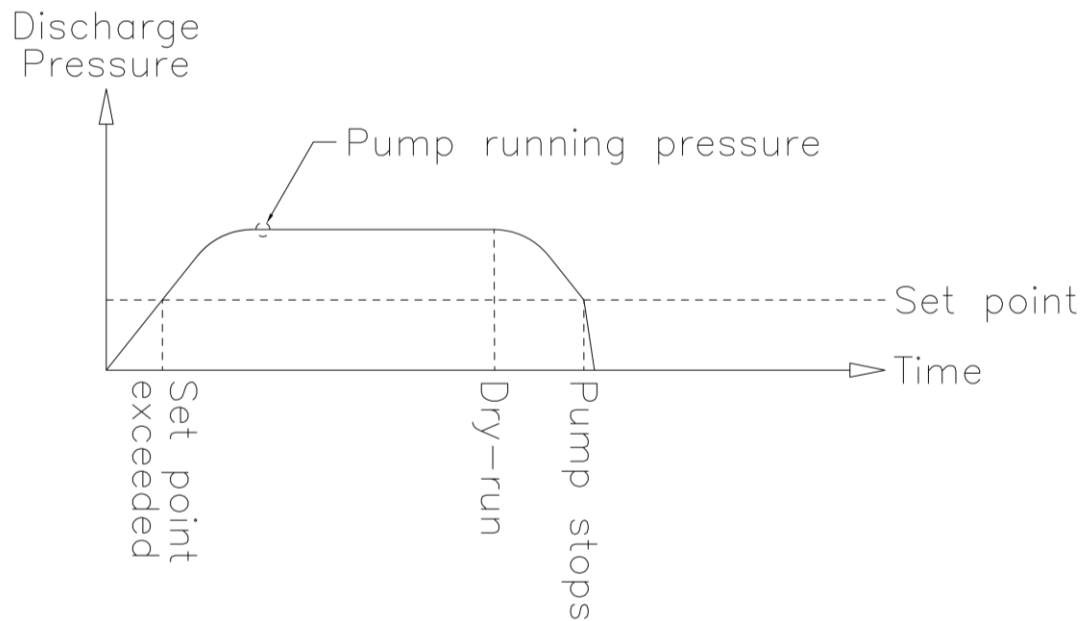

Fig. DR&S-01

Graph of time against pressure showing Dry-run and stop principle

DRY-RUN & STOP (DR&S)

Recommended installation

The Guardian should be installed as per Fig. DR&S-02.

Make sure the Guardian does not cause any tensions or strain on the pump or mounting.

The Guardian must have an air supply of at least 1 bar greater than the required set point.

- **Function plate must be in Pos.1 (see page 6)**
- Media connection is T'd in to the discharge of the pump.
- Air in is connected to a filtered and regulated compressed air source.
- 'Valve O/P' pilots an external pilot valve, sized appropriately for the pumps air inlet, such as a Tapflo TPUK-BV
- 'Alarm O/P' can be connected to a variety of indicators or plugged if not used (see Alarm O/P section of this manual).
- For ATEX applications the Guardian must be bonded using the earth tag.

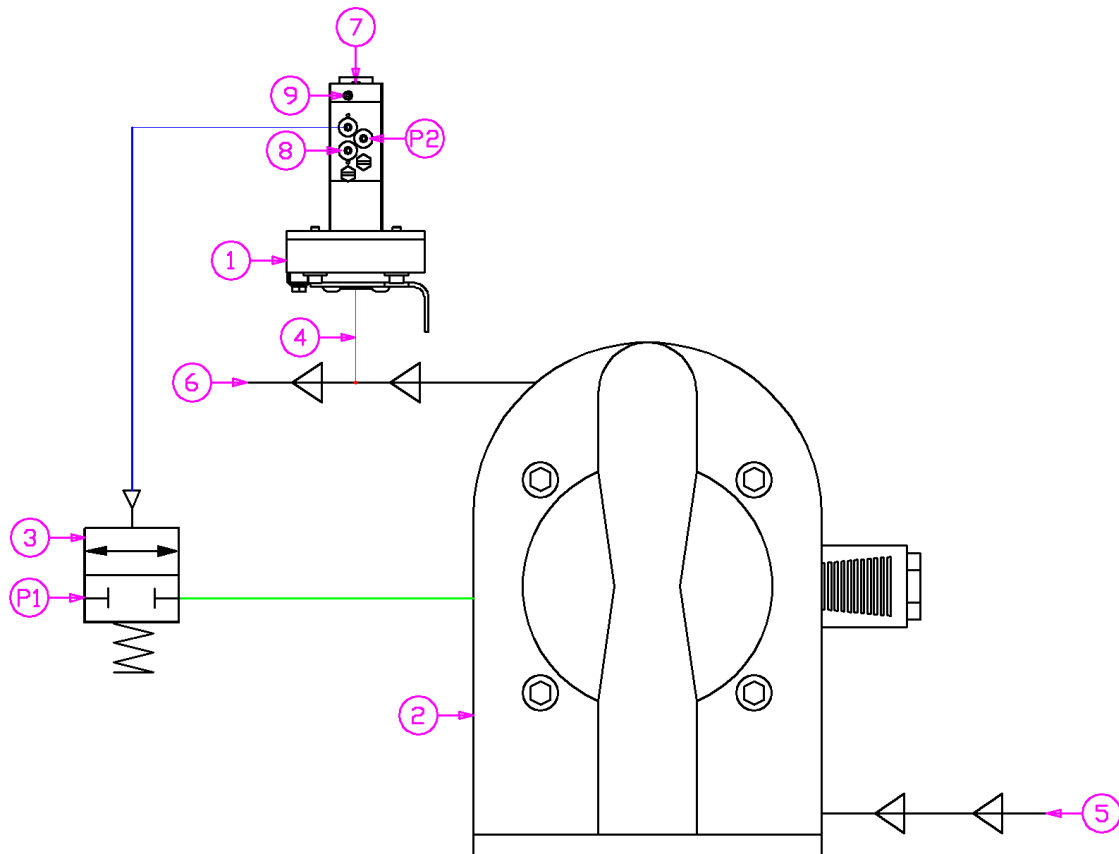

Fig. DR&S-02. Dry-run and stop installation circuit diagram

| | | | |
|----|--|----|-----------------------------|
| P1 | Pump air supply | P2 | Guardian air supply 5-8 bar |
| 1 | Guardian | 2 | Pump (representation) |
| 3 | Pilot valve | 4 | Guardian connection |
| 5 | Pump suction | 6 | Pump discharge |
| 7 | Reset button/visual indicator | 8 | Alarm O/P connection |
| 9 | Reset I/P connection (see page 7 for more details) | | |

DRY-RUN & STOP (DR&S)

Set point adjustment

The Guardian's set point must be set to the optimum trip pressure. To adjust the set point you will require a small flat bladed screwdriver.

Note : DR&S system functionality relies on the discharge of the pump exceeding the set point of the Guardian by circa 0.5-1.0 bar.

The optimum recommended set point for DR&S is 0.7 bar.

To set the Guardian's set point

1. Remove the M5 plug and connect an external pressure gauge with a range of 0-1 bar, to the 'set point O/P' connection.
2. Connect an air supply to air in connection.
3. Plug all other connections, except media and reset I/P.
4. Using a flat bladed screwdriver adjust the set point regulator adjustment screw (Fig.GEN-01, 2) of the Guardian anti-clockwise until it turns freely.
5. Turn on the air supply.
6. Slowly increase the set point regulator adjustment screw (Fig.GEN-01, 2) (clockwise) until the pressure gauge indicates desired pressure (suggested 0.7 Bar).
7. Turn off the air supply.
8. Remove the pressure gauge, and re-install the M5 plug.
9. The set up is now complete and the system is ready for use.

Operation

1. To start the pump, apply compressed air to the pump and Guardian, then Press and hold the reset button and the pump should start. Once primed the reset button should stop opposing, and remain in the depressed position with the pump running.
2. The pump should continue to run until either
 - Air to the pump is interrupted.
 - The pump/Guardian experiences a dry-run condition, which is represented by the reset button popping out.
3. To stop the pump, interrupt the air to the pump and/or Guardian.
4. To re-start the pump
 - Ensure the pump suction is flooded or immersed.
 - Repeat step 1

DRY-RUN & STOP (DR&S)

Trouble shooting

Check the system is configured as shown in the recommended configuration then see possible solutions below. If the problem persists consult Tapflo (UK).

| Symptom | Cause | Remedy |
|------------------------|---|--|
| System is inoperative | Pump failure. | See pump operating manual. |
| | Unstable air supply. | Check all connections and air supply. |
| | Inconsistent pump discharge pressure. | Fit back pressure device such as NRV or orifice plate to stabilize pressure. |
| Pump stops erratically | Set point is not correct. | Perform recalibration. |
| | Air supply is not stable. | Fit air pressure regulator. |
| | Media has changed. | Perform set up procedure. |
| | Leaking interconnections. | Remake or replace interconnections. |
| Guardian does not work | Incorrect configuration. | Check all connections against recommended installation. |
| | Guardian set for alternative application. | Check function plate position. Consult Tapflo (UK) Ltd. |
| | Air pressure too low. | Air pressure must be > 1bar higher than set point. |
| Media egress | Poor installation. | Remake interconnections. |
| | Interconnection specification unsuitable for media. | Check connections are suitable for the application. |
| | Guardian tie rods loose. | Check torque is within specification. |

DEAD-HEAD & STOP (DH&S)

**DEAD-HEAD & STOP
(DH&S)**

DEAD-HEAD & STOP (DH&S)

Principle of operation

The Guardian monitors the fluid discharge pressure of the pump, changing its output if the monitored pressure exceeds the set point of the Guardian, representing a closed valve or over pressure in the pump discharge line, stopping the associate pump accordingly.

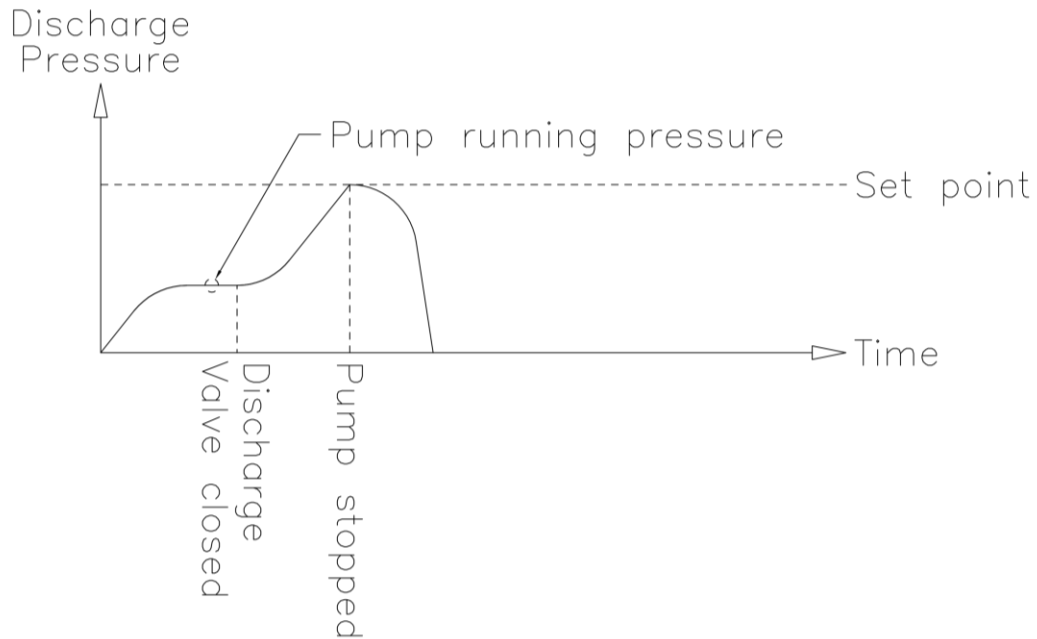

Fig. DH&S-01

Graph of time against pressure showing dead head and stop principle

DEAD-HEAD & STOP (DH&S)

Recommended installation

The Guardian should be installed as per Fig. DH&S-02.

Make sure the Guardian does not cause any tensions or strain on the pump or mounting

The Guardian must have an air supply of at least 1 bar greater than the required set point.

- **Function plate must be in Pos.2 (see page 6).**
- Media connection is T'd in to the discharge pipe work of the pump.
- Air in is connected to a filtered and regulated compressed air source.
- 'Valve O/P' pilots an external pilot valve, sized appropriately for the pumps air inlet, such as a Tapflo TPUK-BV.
- 'Alarm O/P' can be connected to a variety of indicators or plugged if not used (see Alarm O/P section of this manual).
- For ATEX applications the Guardian must be bonded using the earth tag.

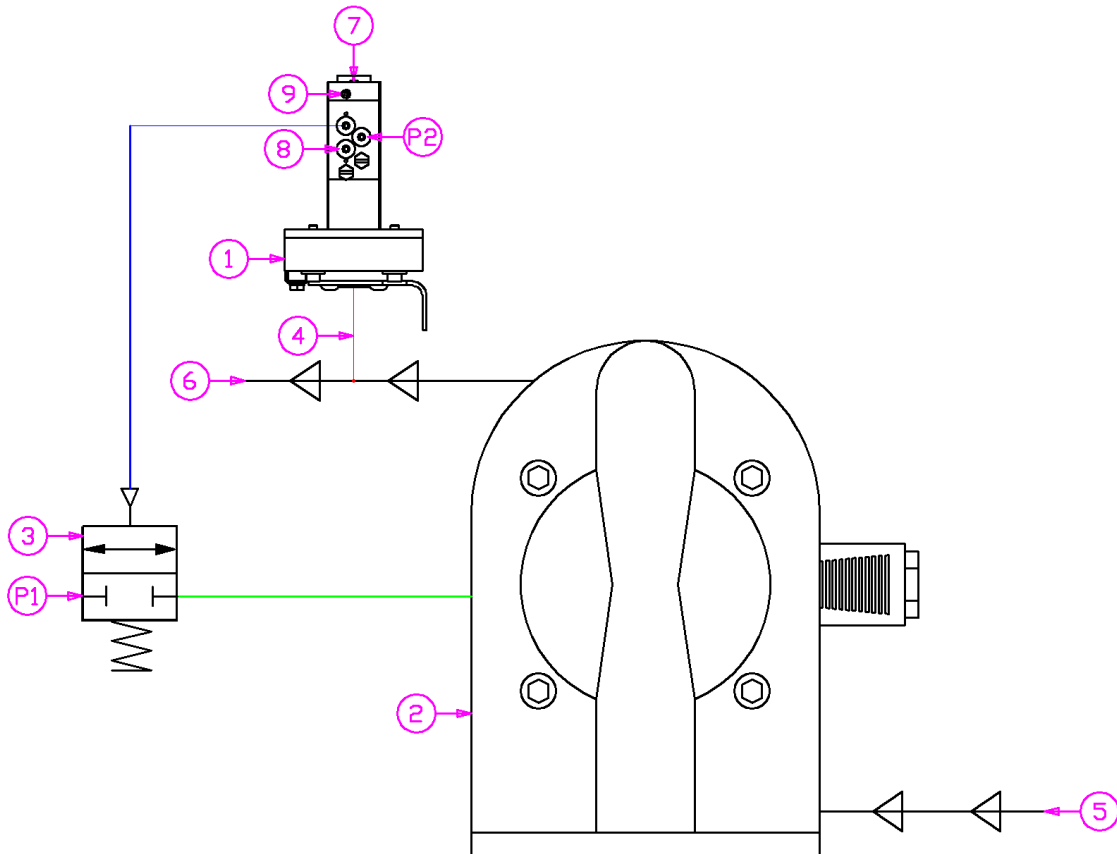

Fig. DH&S-02. Dead-head and stop installation circuit diagram

| | | | |
|----|--|----|-----------------------------|
| P1 | Pump air supply | P2 | Guardian air supply 5-8 bar |
| 1 | Guardian | 2 | Pump (representation) |
| 3 | Pilot valve | 4 | Guardian connection |
| 5 | Pump suction | 6 | Pump discharge |
| 7 | Reset button/visual indicator | 8 | Alarm O/P connection |
| 9 | Reset I/P connection (see page 7 for more details) | | |

DEAD-HEAD & STOP (DH&S)

Set point adjustment

The Guardian's set point must be set to the desired trip pressure. There are three ways to set the Guardian's set point; Representative, Direct or Calculated. To adjust the set point you will require a small flat bladed screwdriver.

Note : DH&S system functionality relies on the discharge of the pump exceeding the set point of the Guardian, with a minimum of circa 0.5-1.0 bar.

Representative

This method of set up adjusts the Guardian to the application by creating the condition in-situ.

1. Using a flat bladed screwdriver adjust the set point regulator adjustment screw (Fig.GEN-01, 2) of the Guardian anti-clockwise until it turns freely.
2. Turn the air supply on.
3. Press and hold the reset button of the Guardian.
4. The pump should start and the reset button should try to extend, continue to hold it in.
5. Slowly increase the set point regulator adjustment screw (Fig.GEN-01, 2) (clockwise) until the reset button stops trying to pop out.
6. Increase the set point regulator clockwise by a further half turn.
7. The Reset button should remain in the in position and the pump can be started and stopped normally by turning the supply to the Guardian on/off, however if not (or it stops the pump erratically) increase the set point regulator adjustment screw (Fig.GEN-01, 2) clockwise in half turn increments until the pump runs consistently.
8. Test the system operates by starting the pump and creating the dead head scenario by closing the discharge valve and ensure the Guardian trips. If not repeat steps 1-7 to check the set point adjustment.
9. The set up is now complete and the system is ready for use.

Direct

This method of set up is used when the set point pressure is known. The Guardian's set point is adjusted using an external source to generate the set point pressure, such as a calibrated air pressure regulator and gauge or a pressure calibrator. This method requires the Guardian to be removed from its installed position and the calibration pressure applied directly to the media connection.

A spare fluid side can be purchased as a test rig, see maintenance section of this manual.

1. Using a flat bladed screwdriver adjust the set point regulator adjustment screw (Fig.GEN-01, 2) of the Guardian anti-clockwise until it turns freely
2. Connect the pressure source to media connection.
3. Plug all other open ports, except reset I/P.

DEAD-HEAD & STOP (DH&S)

4. Connect an air supply to air in connection.
5. Turn the air supply on.
6. Apply the required set point pressure.
7. Press and hold the reset button of the Guardian.
8. Slowly increase the set point regulator adjustment screw (Fig.GEN-01, 2) (clockwise) until the reset button stops trying to pop out.
9. Remove the set point pressure.
10. Press the Reset button and it should remain in the in position
11. Reapply the set point pressure and the reset button should automatically extend.
12. If not repeat steps 6-11.
13. The set point is now adjusted and the system is ready for use.

Calculated

This method of set up is used when the set point pressure is known. The Guardian's set point is simply adjusted to a specific pressure using an external pressure gauge connected to the 'set point O/P' connection.

1. Remove the M5 plug and connect an external pressure gauge to the 'set point O/P' connection.
2. Plug all other open ports, except reset.
3. Using a flat bladed screwdriver adjust the set point regulator adjustment screw (Fig.GEN-01, 2) of the Guardian anti-clockwise until it turns freely.
4. Turn the air supply on.
5. Slowly increase the set point regulator adjustment screw (Fig.GEN-01, 2) (clockwise) until the pressure gauge indicates 0.5 Bar below the required set point (i.e. 3.0 bar switching = 2.5 bar set).
6. Turn off the air supply.
7. Remove the pressure gauge, and re-install the M5 plug.
8. The set point is now adjusted and the system is ready for use.

DEAD-HEAD & STOP (DH&S)

Operation

- To start the pump, apply compressed air to the pump and Guardian.
- The pump should continue to run until either
 1. Air to the pump and/or guardian is interrupted.
 2. The pump/Guardian experiences a dead-head condition, which is represented by the visual indicator of the Guardian extending.
- To stop the pump, interrupt the air to the pump and/or Guardian.
- To re-start the system after a dead-head has occurred
 1. Ensure the dead-head condition has been corrected.
 2. Press the reset button and the pump should re-start (when air is applied).

Trouble shooting

Check the system is configured as shown in the recommended configuration then see possible solutions below. If the problem persists consult Tapflo (UK).

| Symptom | Cause | Remedy |
|------------------------|---|--|
| System is inoperative | Pump failure. | See pump operating manual. |
| | Unstable air supply. | Check all connections and air supply. |
| | Inconsistent pump discharge pressure. | Fit back pressure device such as NRV or orifice plate to stabilize pressure. |
| Pump stops erratically | Set point is not correct. | Perform recalibration. |
| | Air supply is not stable. | Fit air pressure regulator. |
| | Media has changed. | Perform set up procedure. |
| | Leaking interconnections. | Remake or replace interconnections. |
| Guardian does not work | Incorrect configuration. | Check all connections against recommended installation. |
| | Guardian set for alternative application. | Check function plate position. Consult Tapflo (UK) Ltd. |
| | Air pressure too low. | Air pressure must be > 1bar higher than set point. |
| Media egress | Poor installation. | Remake interconnections. |
| | Interconnection specification unsuitable for media. | Check connections are suitable for the application. |
| | Guardian tie rods loose. | Check torque is within specification. |

DEAD-HEAD & RESTART (DH&R)

**DEAD-HEAD & RESTART
(DH&R)**

DEAD-HEAD & RESTART (DH&R)

Principle of operation

The Guardian monitors the fluid discharge pressure of the pump, changing its output if the monitored pressure rises to the set point of the Guardian, representing a closed valve or over pressure in the pump discharge line, stopping the associate pump and automatically restarting it as the dead-head condition is removed.

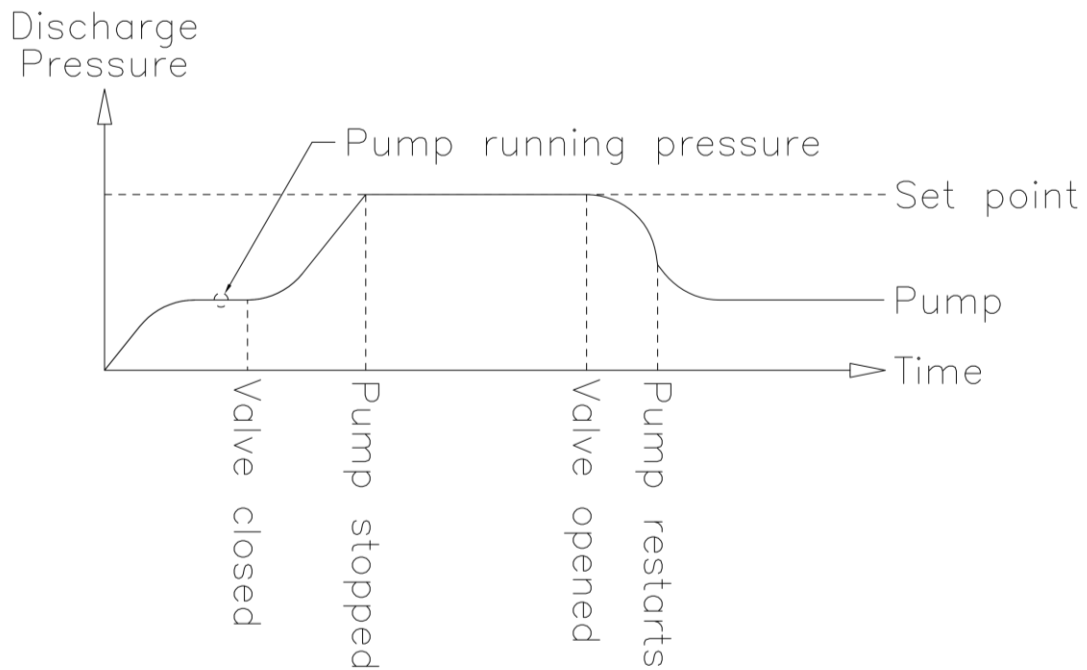

Fig. DH&R-01

Graph of time against pressure showing dead head and restart principle

DEAD-HEAD & RESTART (DH&R)

Recommended installation

The Guardian should be installed as per Fig. DH&R-02.

Make sure the Guardian does not cause any tensions or strain on the pump or mounting.

The Guardian must have an air supply of at least 1 bar greater than the required set point.

- **Function plate must be in Pos.1 (see page 6).**
- Media connection is T'd in to the discharge pipe work of the pump.
- Air in is connected to a filtered and regulated compressed air source.
- 'Valve O/P' is plugged.
- DH&R O/P pilots an external pilot valve, sized appropriately for the pumps air inlet, such as a Tapflo TPUK-BV.
- Alarm O/P is not representative and should not be used.
- For ATEX applications the Guardian must be bonded using the earth tag.

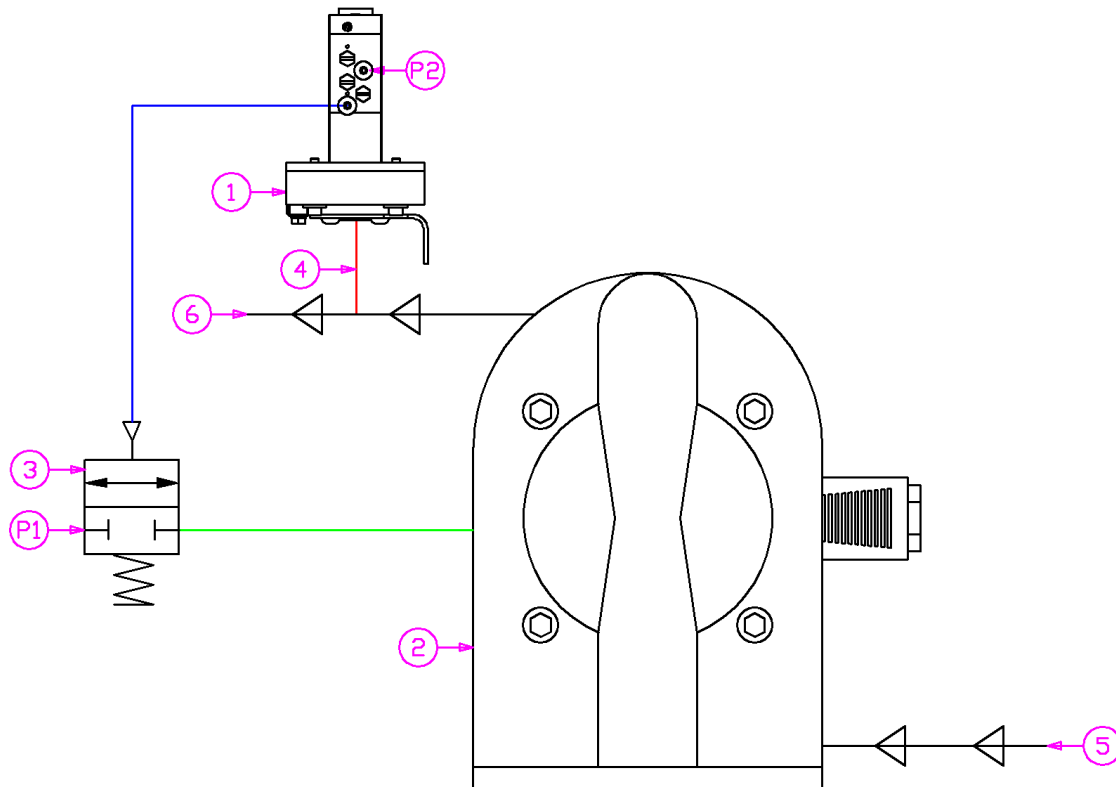

Fig. DH&R-02. Dead-head and restart installation circuit diagram

| | | | |
|----|-----------------|----|-----------------------------|
| P1 | Pump air supply | P2 | Guardian air supply 5-8 bar |
| 1 | Guardian | 2 | Pump (representation) |
| 3 | Pilot valve | 4 | Guardian connection |
| 5 | Pump suction | 6 | Pump discharge |

DEAD-HEAD & RESTART (DH&R)

Set point adjustment

The Guardian's set point must be set to the desired trip pressure. There are three ways to set the Guardian's set point; Representative, Direct or Calculated. To adjust the set point you will require a small flat bladed screwdriver.

Note : DH&R system functionality relies on the discharge of the pump exceeding the set point of the Guardian, with a minimum of circa 0.5-1.0 bar.

Note : The visual indicator/reset button is not used for DH&R functionality.

Representative

This method of set up adjusts the Guardian to the application by creating the condition in-situ.

1. Using a flat bladed screwdriver adjust the set point regulator adjustment screw of the Guardian anti-clockwise until it turns freely.
2. Turn the air supply on.
3. The pump should not start.
4. Slowly increase the set point regulator adjustment screw (Fig.GEN-01, 2) until the pump starts.
5. Increase the set point regulator clockwise by a further half turn.
6. The pump can be started and stopped normally by turning the supply to the Guardian on/off, however if not (or it stops the pump erratically) increase the set point regulator clockwise in half turn increments until the pump runs consistently.
7. Test the system operates by starting the pump and creating the dead-head scenario by closing the discharge valve and ensure the Guardian trips and the pump stops. To test the guardian's state press the reset button and it should remain in.
8. Remove the dead-head by opening the discharge valve, the pump should start automatically and the reset button should pop out. If not repeat steps 1-7 to check the set point adjustment.
9. The set up is now complete and the system is ready for use.

Direct

This method of set up is used when the set point pressure is known. The Guardian's set point is adjusted using an external source to generate the set point pressure, such as a calibrated air pressure regulator and gauge or a pressure calibrator. This method requires the Guardian to be removed from its installed position and the calibration pressure applied directly to the media connection.

A spare fluid side can be purchased as a test rig, see maintenance section of this manual.

1. Using a flat bladed screwdriver adjust the set point regulator adjustment screw (Fig.GEN-01, 2) of the Guardian anti-clockwise until it turns freely.

DEAD-HEAD & RESTART (DH&R)

2. Connect the pressure source to media connection.
3. Plug all other open ports, except reset I/P.
4. Connect an air supply to air in connection.
5. Connect a gauge or visual indicator to DH&R O/P connection.
6. Turn the air supply on.
7. The gauge should indicate system pressure or the visual indicator should be set.
8. Apply the required set point pressure.
9. Slowly increase the set point regulator adjustment screw (Fig.GEN-01, 2) (clockwise) until the DH&R O/P signal disappears.
10. Remove the set point pressure and the DH&R O/P signal should return.
11. Reapply the set point pressure and the DH&R O/P signal should disappear. If not repeat steps 6-10.
12. The set point is now adjusted and the system is ready for use.

Calculated

This method of set up is used when the set point pressure is known. The Guardian's set point is simply adjusted to a specific pressure using an external pressure gauge connected to the 'set point O/P' connection.

1. Remove the M5 plug and connect an external pressure gauge to the 'set point O/P' connection.
2. Plug all other open ports, except reset I/P.
3. Using a flat bladed screwdriver adjust the set point regulator adjustment screw (Fig.GEN-01, 2) of the Guardian anti-clockwise until it turns freely
4. Turn the air supply on.
5. Slowly increase the set point regulator adjustment screw (Fig.GEN-01, 2) (clockwise) until the pressure gauge indicates 0.5 Bar below the required set point (i.e. 3.0 bar switching = 2.5 bar set).
6. Turn off the air supply.
7. Remove the pressure gauge, and re-install the M5 plug.
8. The set point is now adjusted and the system is ready for use.

Operation

- To start the pump, apply compressed air to the pump and Guardian.
- The pump should continue to run until either
 1. Air to the pump or guardian is interrupted.
 2. The pump/Guardian experiences a dead-head condition, which stops the pump.
 3. The pump will re-start automatically when the dead-head condition is removed.
- To stop the pump, interrupt the air to the pump and/or Guardian.

DEAD-HEAD & RESTART (DH&R)

Trouble shooting

Check the system is configured as shown in the recommended configuration then see possible solutions below. If the problem persists consult Tapflo (UK).

| Symptom | Cause | Remedy |
|------------------------|---|--|
| System is inoperative | Pump failure. | See pump operating manual. |
| | Unstable air supply. | Check all connections and air supply. |
| | Inconsistent pump discharge pressure. | Fit back pressure device such as NRV or orifice plate to stabilize pressure. |
| Pump stops erratically | Set point is not correct. | Perform recalibration. |
| | Air supply is not stable. | Fit air pressure regulator. |
| | Media has changed. | Perform set up procedure. |
| | Leaking interconnections. | Remake or replace interconnections. |
| Guardian does not work | Incorrect configuration. | Check all connections against recommended installation. |
| | Guardian set for alternative application. | Check function plate position. Consult Tapflo (UK) Ltd. |
| | Air pressure too low. | Air pressure must be > 1bar higher than set point. |
| Media egress | Poor installation. | Remake interconnections. |
| | Interconnection specification unsuitable for media. | Check connections are suitable for the application. |
| | Guardian tie rods loose. | Check torque is within specification. |

SPECIFICATIONS

Dimensions

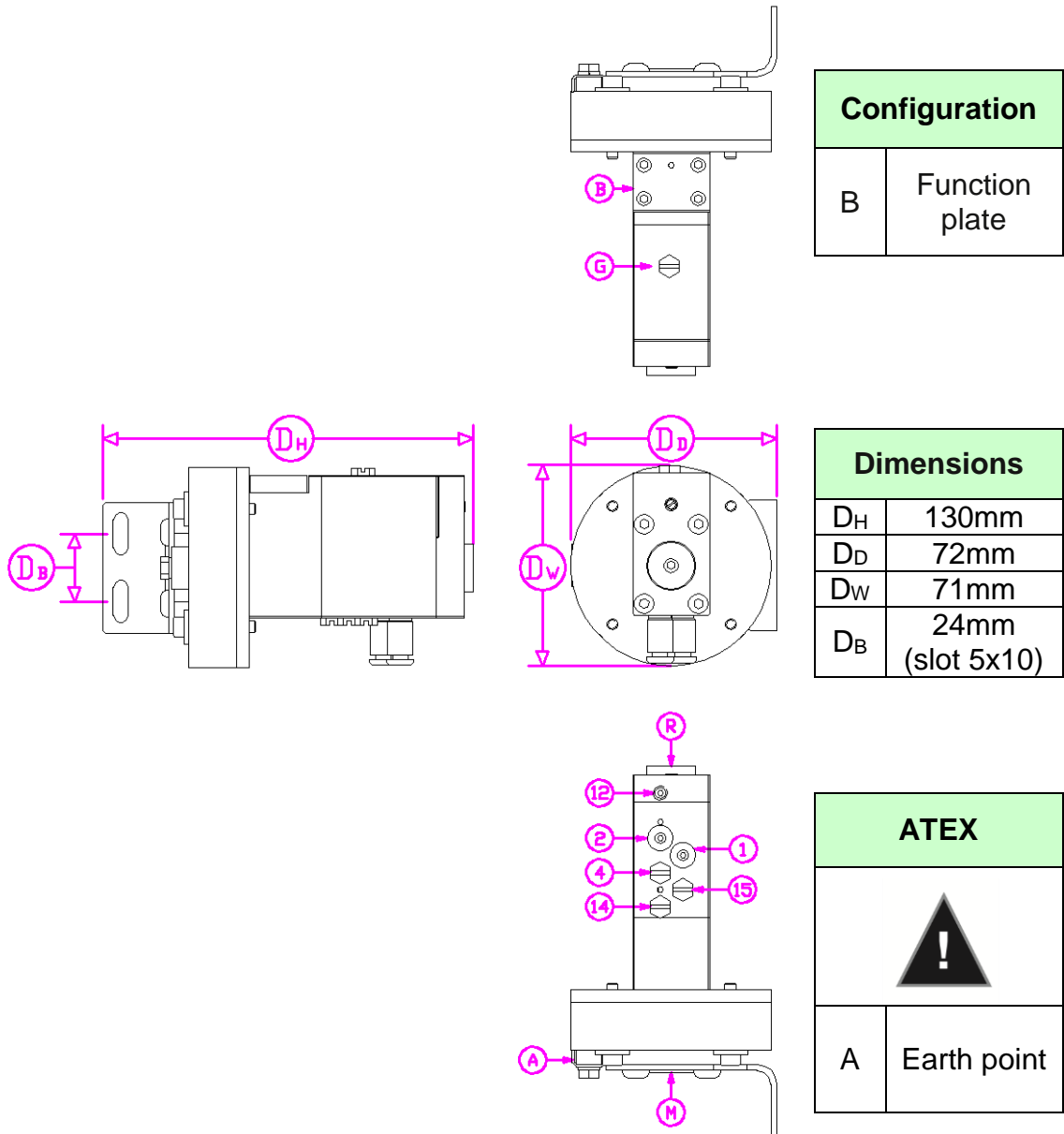

Fig.SP-01

Connections

| Port No. | Description | Connection type |
|----------|-----------------|-----------------------|
| 12 | Reset I/P | M5 |
| 2 | Valve O/P | 4mm push fit |
| 1 | Air in | 4mm push fit |
| 4 | Alarm O/P | M5 (Supplied plugged) |
| 14 | DH&R O/P | M5 (Supplied plugged) |
| M | Media I/P | 1/4" BSP (F) |
| G | Set point O/P | M5 (Supplied plugged) |
| 15 | Precision Bleed | M5 (Supplied plugged) |

SPECIFICATIONS

| Characteristics | | | | |
|--------------------|---------------------------|----------------------------|--------|----------------------|
| | | 316L | | PTFE (conductive) |
| Temperature range | Ambient | -5°C to +40°C | | |
| | Media | -20°C to +110°C | | |
| Air pressure | | 5 - 8 BAR (See note below) | | |
| Media I/P pressure | Range (See note below) | 0.7 - 7 BAR | | |
| | Absolute Maximum pressure | 12 BAR | 25 BAR | 8 BAR |
| Weight | | 1100g | 1400g | 1100g |

Note : Air in must be 1 bar greater than the set point.

Guardian coding

The code details the specifications, function and materials of construction of the wetted parts.

Example : **TPUK-GU4X-ST**

| Manufacturer | Product | Atex | Material of wetted housing | Material of diaphragm |
|--------------|---------------|---------------|----------------------------|-----------------------|
| TPUK | GU4 | X | - | T |
| Tapflo (UK) | Guardian Mk.4 | ATEX approved | S = 316L | PTFE |
| | | | T = PTFE (conductive) | |

MAINTENANCE

Routine inspection

Routinely check the function and set up, as normal wear can affect performance. To check set up; follow the instructions in the application specific sections of this manual.

The unit maintenance free.

Complete inspection

Before dismantling the Guardian be sure to



- Drain all liquid from the system.
- Cleanse or neutralize the Guardian thoroughly.
- Disconnect the air supply

Dismantling procedure (See Fig. SP-01)

1. Undo tie rods and remove air-side assembly from the fluid-side of the Guardian.
2. Inspect the diaphragm surface for damage.



If the diaphragm is undamaged reassemble the guardian and perform the set up procedure detailed in this manual.

If the diaphragm is damaged there is a possibility the media has penetrated the internals of the guardian air side, causing damage to the seals, etc'. **DO NOT RETURN TO SERVICE.** Please consult Tapflo (UK) regarding replacement parts.

Assembling the Guardian



1. Replace the air side with the fluid side.
2. Equally tighten the tie-rods Fig.MA-01 (11) to the torque detailed in the table below.

Tightening torques

| | |
|-------------------|-------|
| 316L | 3.8Nm |
| PTFE (conductive) | |

MAINTENANCE

Guardian parts

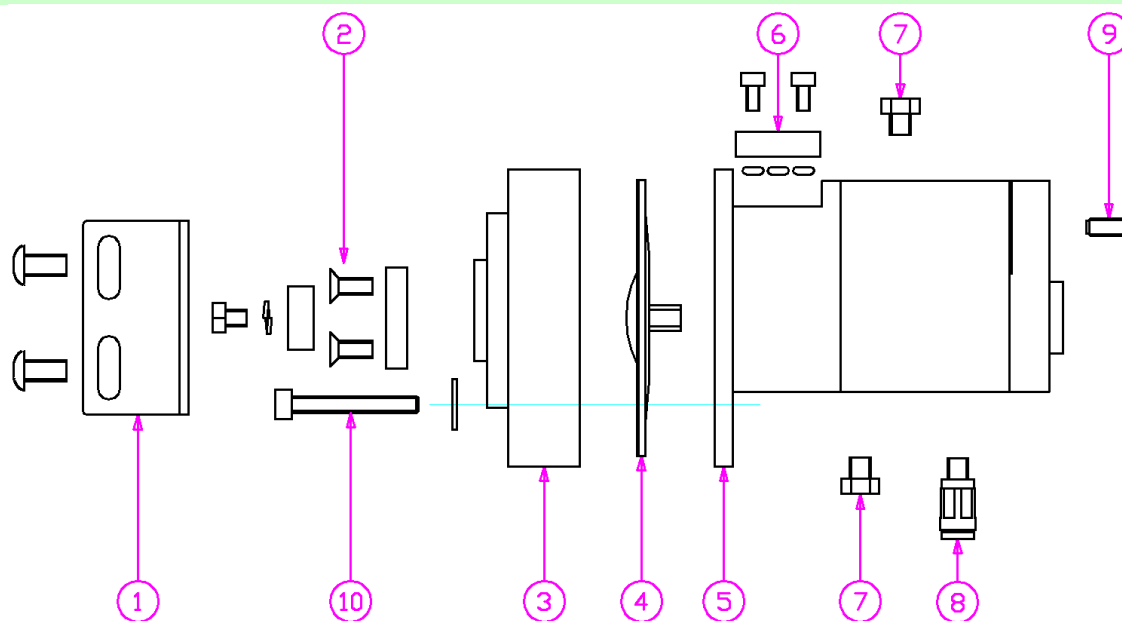

Fig.MA-01

| | Description | Qty per Guardian | Part No. |
|----|------------------------------|------------------|---|
| 1 | Bracket assembly | 1 | G-BRACKET |
| 2 | Earth tag assembly | 1 | G-TAG |
| 3 | Fluid side | 1 | 316L TPUK-GU4X-FLUID-316 |
| | | | PTFE (Conductive) TPUK-GU4X-FLUID-TT |
| 4 | Diaphragm | 1 | 6-009-15-1 |
| 5 | Air side assembly | 1 | TPUK-GU4X-AIR |
| 6 | Function plate assembly | 1 | G-FPLATE |
| 7 | M5 port plugs | 4 | PF-X/M5-PLUG |
| 8 | 4mm to M5 push fit connector | 4 | PF-4/M5-STUD |
| 9 | Set point regulator screw | 1 | TPUK-X-00469 |
| 10 | Fasteners/washers | 4 | F-SOCCAP-M4X30-A2-70 |
| | | 4 | F-WASHER-M4X12-A2 |

Returning parts

To return parts to Tapflo (UK) please follow this procedure.

- Consult Tapflo (UK) for shipping instructions
- Cleanse, neutralise and rinse the part making sure the part is completely free from media
- Provide a certificate of decontamination, where appropriate
- Complete the Warranty / Returns form on following page and return articles carefully to prevent any damage during transport

WARRANTY

Warranty

Tapflo UK warrants products under conditions as below for a period of not more than 12 months from installation and not more than 24 months from date of manufacture.

1. The following terms and condition apply to the sale of machinery, components and related services and products, of Tapflo UK (hereinafter "the products")
2. Tapflo UK (the manufacturer) warrants that:
 - a. its products as being free of defects in material, design and workmanship at the time of original purchase;
 - b. its products will function in accordance with Tapflo UK operative manuals; Tapflo UK does not guarantee that the product will meet the precise needs of the Customer, except for those purposes set out in any invitation to tender documents or other documents specifically made available to Tapflo UK before entering into this agreement;
 - c. high quality materials are used in the construction of the products and that machining and assembly are carried out to the highest standards.

Except as expressly stated above, Tapflo UK makes no warranties, express or implied, concerning the products, including all warranties of fitness for a particular purpose.

3. This warranty shall not be applicable in circumstances other than defects in material, design, and workmanship. In particular warranty shall not cover the following:
 - a. Periodic checks, maintenance, repair and replacement of parts due to normal wear and tear (seals, O-rings, rubber items, bushings, etc.);
 - b. Damage to the product resulting from:
 1. Tampering with, abuse or misuse, including but not limited to failure to use the product for its normal purposes as stated at the time of purchase or in accordance with Tapflo UK instructions for use and maintenance of the product, or the installation or improper ventilation or use of the product in a manner inconsistent with the technical or safety standard in force;
 2. Repairs performed by non-skilled personnel or use of non-original Tapflo UK parts
 3. Accidents or any cause beyond the control of Tapflo UK, including but not limited to lightning, water, fire, earthquake, and public disturbances, etc.;
4. The warrantee shall cover the replacement or repairing of any parts, which is documentedly faulty due to construction or assembling, with new or repaired parts free of charges delivered by Tapflo. Parts subjected to normal tear and wear shall not be covered by the warranty. Tapflo shall decide as to whether the defective or faulty part shall be replaced or repaired.
5. The warrantee of the products shall be valid for a period in accordance to the current law from the date of delivery, under the condition that notice of the alleged defect to the products or parts thereof be given to Tapflo UK in written within the mandatory term of 8 days from the discovery.
6. Repair or replacement under the terms of this warranty shall not give a right to an extension to, or a new commencement of, the period of warranty. Repair or replacement under the terms of this warranty may be fulfilled with functionally equivalent reconditioned units. Tapflo UK qualified personnel shall be solely entitled to carry out repair or replacement of faulty parts after careful examination of the pump. Replaced faulty parts or components will become the property of Tapflo UK
7. The products are built in accordance with standard CE normative and are tested (where applicable) by Tapflo UK. Approval and tests by other control authority are for the customers account. The products shall not be considered defective in materials, design or workmanship if they need to be adapted, changed or adjusted to conform to national or local technical or safety standards in force in any country other than that for which the unit was originally designed and manufactured. This warranty shall not reimburse such adaptations, changes or adjustments, or attempt to do so, whether properly performed or not, nor any damage resulting from them, nor any adaptation, change or adjustments to upgrade the products from their normal purpose as described in the products operative manual without the prior written consent of Tapflo UK
8. Installation, including electric and other connections to utility mains according to Tapflo UK drawings, is for the cost and responsibility of the customer, unless otherwise agreed in writing.
9. Tapflo UK will not be liable on any claim, whether in contract, tort, or otherwise, for any indirect, special, incidental, or consequential damages, caused to the customer or to third parties, including loss of profits, arising by any possible infringement of par. 3 above or by the customer or third parties being in the impossibility of using the products.

Notwithstanding the above, Tapflo UK liability to the customer or third parties from any claim, whether in contract, tort, or otherwise, shall be limited to the total amount paid by the customer for the product that caused the damages.

WARRANTY

| Warranty / return form | | | |
|----------------------------------|--|----------------------|--|
| Company | | | |
| Address | | | |
| Country | | | |
| Contact Name | | | |
| Telephone | | Fax | |
| E-mail | | | |
| Delivery date | | Install date | |
| System Type | | Serial No. | |
| Description of fault | | | |
| Media | | | |
| Temperature (°C) | | Viscosity (cPs) | |
| Spec. grav. (Kg/m ³) | | pH (Value) | |
| Particle content (%) | | Particle size (mm) | |
| Duty (h/day) | | Starts per day (No.) | |
| Media Pressure (bar) | | | |
| Air pressure (bar) | | Air quality | |
| Notes | | | |

WARRANTY

Warranty / return form

Sketch of installation

Whilst every effort has been made to ensure that all the information contained in this document is correct at the time of publication, due to our policy of continuous product improvement, the company reserves its right to change any information contained herein without notice.



Tapflo UK Ltd -
Tapflo House, Victory Close, Chandlers Ford, Hampshire SO53 4BU
t: +44 (0)23 8025 2325 f: +44 (0)23 8026 9016
e: sales@tapflopumps.co.uk w: www.tapflopumps.co.uk

DISTRIBUTOR: