

IOM manual

tapflo®

## DPT series Hose Pump Pulsation Dampener

Original Instruction

edition 2022 rev 3



Read this instruction manual carefully,  
before you install and operate the dampener.



Dampener models:

DPT40

DPT65

DPT100

DPT125



» All about your flow

[www.tapflo.com](http://www.tapflo.com)

# CONTENTS

---

<b>0. GENERAL</b> .....	5
0.1. Introduction.....	5
0.2. Warning symbols .....	5
0.3. Qualification and training of personnel.....	5
0.4. Nameplate .....	6
<b>1. INSTALLATION</b> .....	7
1.1. Operation principle.....	7
1.2. Receiving inspection.....	7
1.3. Lifting and transportation.....	8
1.4. Storage.....	8
1.5. Foundation .....	8
1.6. Environment .....	8
1.7. Health and safety .....	9
1.7.1. Protection .....	9
1.7.2. Chemical hazard .....	9
1.7.3. Air and system pressure .....	9
1.7.4. Noise level .....	9
1.7.5. Temperature hazards.....	9
1.7.6. Explosion hazardous environments – ATEX.....	10
<b>2. OPERATION</b> .....	11
2.1. Before operating the dampener .....	11
2.2. Pressurizing procedure.....	11
2.3. Disposal after expiration of the expected lifetime .....	11
2.4. Actions in emergency .....	12
2.5. Residual risks .....	12
<b>3. MAINTENANCE</b> .....	13
3.1. When the dampener is new or reassembled.....	13
3.2. Routine inspection .....	13
3.3. Complete inspection .....	13
3.4. Location of faults .....	14
3.5. Disassembly of the dampener.....	15
3.5.1. Before the disassembly procedure .....	15
3.5.2. Disassembly procedure.....	15
3.6. Assembly of the dampener .....	17
3.6.1. Test run .....	17

# CONTENTS

---

<b>4. SPARE PARTS</b> .....	18
4.1. Exploded view .....	18
4.2. Spare parts list.....	18
4.3. Stocking recommendation .....	19
4.4. How to order parts.....	19
4.5. Dampener code .....	19
<b>5. DATA</b> .....	20
5.1. Overall dimensions .....	20
5.2. Tightening torques .....	21
5.3. Technical data .....	21
5.4. Permitted loads on manifolds.....	22
<b>6. WARRANTY</b> .....	23
6.1. Warranty form.....	23
6.2. Returning parts .....	24
6.3. Warranty .....	24

## EU Declaration of Conformity 01/EU/DPT/2022

Series: **DPT(...)**

Manufacturer: **Tapflo Group AB, Filaregatan 4, 442 34 Kungälv, Sweden,**

**This declaration of conformity is issued under the sole responsibility of the manufacturer.**

Object of the declaration: **PULSATION DAMPENERS**

The object of the declaration described above is in conformity with the relevant Union harmonization legislation and the technical specifications:

- Pressure Equipment Directive **2014/68/EU**
- Conditions of the Office of Technical Inspection (UDT) - **WUDT/UC/2003**

Conformity assessment procedure followed:

Pressure equipment	Name	Equipment category	Evaluation module
<b>Assembly</b>	<b>Pulsation dampener DPT40</b>	<b>Category I</b>	<b>Module A</b>
<b>Assembly</b>	<b>Pulsation dampener DPT 65</b>	<b>Category II</b>	<b>Module A2</b>
<b>Assembly</b>	<b>Pulsation dampener DPT 100</b>	<b>Category II</b>	<b>Module A2</b>
<b>Assembly</b>	<b>Pulsation dampener DPT 125</b>	<b>Category II</b>	<b>Module A2</b>

Certificate of Conformity number: **96199/JN/001/04**

Notified body number: **1433**

Notified body: **Office of Technical Inspection (UDT), ul. Szczęśliwicka 3402-353 Warsaw, Poland**

Tapflo Group AB



Per Antonsson  
Chief Executive Officer  
Kungälv, 04.07.2022r.

# 0. GENERAL

---

## 0. GENERAL

### 0.1. Introduction

The pulsation dampener is the most efficient way to remove pressure variations on the discharge of the pump. The DPT pulsation dampener works with a pre-set value of compressed air and a tubular diaphragm (hose), to minimize the pulsations. The pulsation dampener is available for all Tapflo hose pump sizes and material versions.

With proper attention to maintenance, Tapflo pulsation dampeners will give efficient and trouble free operation. This instruction manual will familiarize operators with detailed information about installing, operating and maintaining the dampener.

### 0.2. Warning symbols

The following warning symbols are present in this instruction manual. This is what they say:



This symbol stands next to all safety instructions in this instruction manual where danger to life and limb may occur. Observe these instructions and proceed with utmost caution in these situations. Inform also other users of all safety instructions. In addition to the instructions in this instruction manual, the general safety and accident prevention regulations must be observed.



This signal stands at points in this instruction manual of particular importance for compliance with regulations and directives, for correct work flow and for the prevention of damage to and destruction of the complete dampener or its subassemblies.

### 0.3. Qualification and training of personnel



The personnel in charge of installation, operation and maintenance of the dampener must be qualified to carry out the operations described in this manual. Tapflo shall not be held responsible for the training level of personnel and for the fact that they are not fully aware of the contents of this manual.



In case any instructions in this manual are unclear or any information is lacking, please contact Tapflo before handling the dampener.

# 0. GENERAL



## 0.4. Nameplate

The nameplate is made in the below design. It is made of AISI 304 stainless steel and placed on the flange bracket. Nameplate dimensions are 44 x 90 mm.

### ➤ DPT40

			
Tapflo Group AB, <a href="http://www.tapflo.com">www.tapflo.com</a> Filaregatan 4   S-442 34 Kungälv, Sweden			
Unit type		Serial Number	Mfg year
V [l]	DN	TS min. / TS max. [°C]	
PT [bar]	Test date	PS [bar]	PZ [bar]

### ➤ DPT65, DPT100, DPT125

			
Tapflo Group AB, <a href="http://www.tapflo.com">www.tapflo.com</a> Filaregatan 4   S-442 34 Kungälv, Sweden			
Unit type		Serial Number	Mfg year
V [l]	DN	TS min. / TS max. [°C]	
PT [bar]	Test date	PS [bar]	PZ [bar]

Where:

- **V** – internal volume
- **DN** – Nominal unit dimension
- **TS max.** – Maximum allowable liquid temperature
- **TS min.** – Minimum allowable liquid temperature
- **PT** – Test pressure (PSx1,43)
- **PS** – Maximum allowable pressure
- **PZ** – Setting of the pressure safety valve

# 1. INSTALLATION

---

## 1. INSTALLATION

### 1.1. Operation principle

The pulsation dampener's main function is to remove pressure variations on the discharge of the pump. The dampener works with compressed air and a diaphragm, to minimise the pulsations.

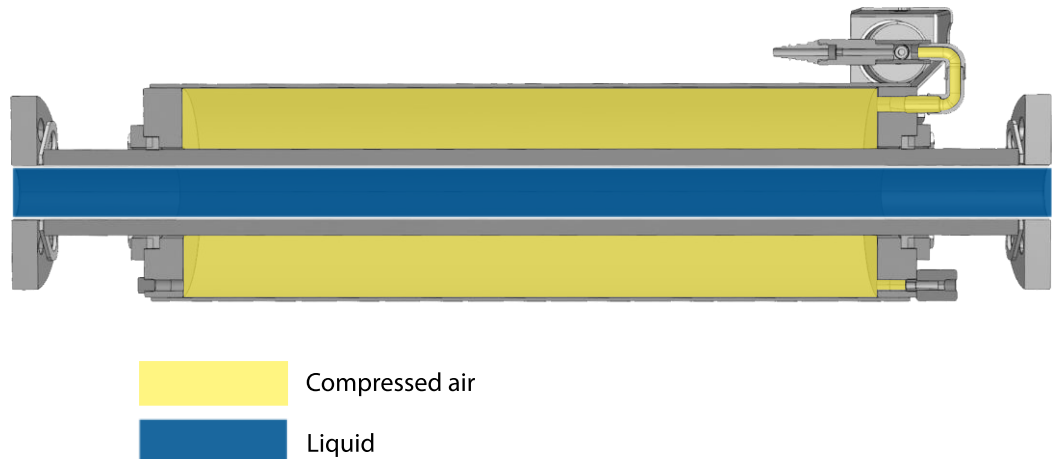

The air pressure supplied to the dampener must be equal to 85% of the pump discharge pressure. The medium flowing through the dampener affects the hose, which by means of the compressed air on the air side compensates the fluctuations of pressure in the discharge line. The air concentrated in the dampeners block works as a spring for the medium flowing through the dampener.

When operating, the dampener does not consume compressed air. It is only consumed during setting phase, when pump duty point is being changed.

### 1.2. Receiving inspection

Although precaution is taken by us when packing and shipping, we urge you to carefully check the shipment on receipt. Make sure that all parts and accessories listed on the packing list are accounted for. Immediately report any damage or shortage to the transport company and to us.

# 1. INSTALLATION

## 1.3. Lifting and transportation



**Be careful!** The dampener contains protruding elements standing out of the product outline. Make sure not to hit or damage these elements during transport and handling. Before handling the dampener check the weight of the dampener (see 6.3. *Data*). Refer to Your local standards on how to handle the dampener. If the weight is excessive to transport by hand it must be lifted using slings and a suitable lifting device e.g. a crane or forklift.

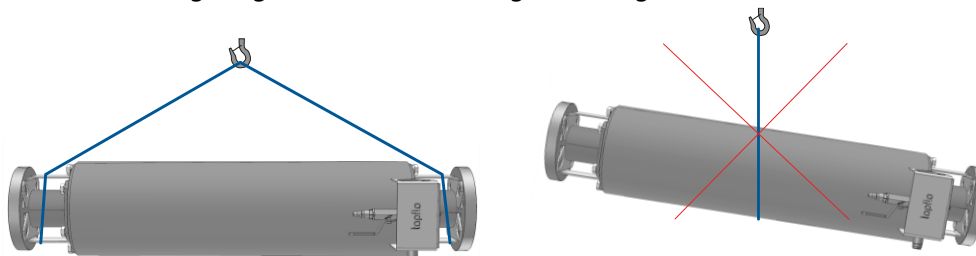

Never lift the dampener under pressure.  
Be careful that nobody passes under the dampener when lifted.

## 1.4. Storage



If the equipment is to be stored prior to installation, place it in a clean location. The dampener should be stored in an ambient temperature of 15°C (59°F) to 25°C (77°F) and relative humidity below 65%. It should not be exposed to any heat source e.g. radiator, sun as this could result in a negative way on the tightness of the dampener. Do not remove protective covers from the inlet/outlet and air connections which have been fastened to keep dampener internals free of debris. Clean the dampener thoroughly before installation.

Spare hoses must be stored in the same conditions as the dampener. What is more, they should be protected from direct sunlight. Rubber materials are subject to aging and their performance and lifetime decrease with time.

**NOTE!** Do not remove protective covers from the hose when in storage.

## 1.5. Foundation



The dampener should be placed on a base frame or support to avoid possibility of rotating during operation. What is more, the dampener cannot hang freely on the pump connections as it will create strain and in the long run leakage on the connections.

**Note!** The dampener has to be installed in such a way that the loads on manifolds stated in chapter 5.4. are not exceeded.

## 1.6. Environment



- There should be enough space in the vicinity of the dampener in order to operate, maintain and repair it.
- The area in which the dampener is operated, must be sufficiently ventilated. Excessive temperature, humidity or dirt may affect the dampener operation.

# 1. INSTALLATION

---

## 1.7. Health and safety

The pulsation dampener must be installed according to local and national safety rules.



**The dampeners are constructed for particular applications. Do not use the dampeners on applications different from that for which it was sold without consulting us to ascertain its suitability.**



The dampeners are tested with water. If the pumped product can come into reaction with water, please make sure the device is dry before putting it into operation.

### 1.7.1. Protection



The dampener build consists of some protruding elements that can cause injury.

In the interest of health and safety it is essential to wear protective clothing and safety goggles when operating, and/or working in the vicinity of Tapflo dampeners.

### 1.7.2. Chemical hazard



Whenever the dampener is to be used for use with a different liquid, it is essential to clean the dampener beforehand in order to avoid any possible reaction between the two products.

### 1.7.3. Air and system pressure



The working pressure for standard Tapflo dampeners is 15 bar @ 20°C for DPT40 and 10 bar @ 20°C for DPT65, DPT100 and DPT125.

The dampener maximum air supply pressure is 10 bar. This is a safety measure in case of pressure peaks. Higher air pressure or elevated temperature can damage the dampener and may cause injury to personnel in vicinity of the dampener.

The dampener is equipped as standard with a pressure safety valve pre-set to the maximum allowable pressure of the dampener @ 20°C. The setting must be adjusted by the end user based on the application.



Although the dampener is equipped with a pressure safety valve, an auxiliary safety valve should always be present also on the installation side.

### 1.7.4. Noise level



At tests, the noise level from a Tapflo dampener has not exceeded 70 dB(A). Under some circumstances, for example if the dampener is operating under high air pressure at low discharge head, the noise can be inconvenient or hazardous for personnel staying for long periods in the vicinity of the dampener. This hazard can be prevented by:

- using suitable ear protection;
- lowering the air pressure and/or raising the discharge head.

### 1.7.5. Temperature hazards

- Raised temperature can cause damage on the dampener and/or piping and may also be hazardous for personnel in the vicinity of the dampener/piping. Avoid quick temperature changes and do not exceed the maximum temperature specified when the dampener was

# 1. INSTALLATION



- ordered. See also general max temperatures based on water in chapter 5.3. "Technical data".
- When the dampener is exposed to ambient temperature variations or if there is big difference between the temperature of the product and the surrounding, the tightening torques of the housing nuts should be checked periodically as part of preventive maintenance.
  - If a hot product is pumped, the dampener should not stand still when filled for a longer period of time. This could cause leakage.
  - Below 0°C (32°F) plastic materials become more fragile what can cause increased wear of parts made of these materials. This is a hazard that has to be accepted when pumping cold products. Also in such case, when a dampener is not operation it should be drained of all liquid.
  - The fluid remaining in the connected piping, as well as in the dampener itself, may expand because of freezing or heat, which may cause damage to the dampener or/and piping, and lead to leakage of the fluid.
  - Always monitor the liquid temperature in order to avoid exceeding dampener max allowable temperature.

## 1.7.6. Explosion hazardous environments – ATEX

The DPT dampeners are categorized in Directive 2014/34/EU as simple products. They do not have their own ignition sources, such as: electric sparks, arcs and flashes, electrostatic discharges, electromagnetic waves, ionising radiation, hot surfaces, flames and hot gases, mechanically generated sparks, optical radiation, chemical flame initiation or compression. The only source of electrostatic charging of the product may come from the process and such a product is not considered to have its own ignition source and it **does not fall under the scope of Directive 2014/34/EU**. Additionally, the device must be earthed to protect against the accumulation of electrostatic charges. The casing of the dampener is made of stainless steel.



### Earth connection of the dampener and other equipment

Connect a suitable earth wire to drilled hole on one of the dampener brackets. The hole is marked with a suitable grounding sticker.

Connect the other end of the earth wire to earth and also make sure that other equipment like hoses/pipes/containers etc. are properly earthed/connected.

**NOTE!** Only NR and EPDM hose (non FDA) can be used for ATEX application.



## 2. OPERATION

---

### 2. OPERATION

#### 2.1. Before operating the dampener



- Make sure the dampener is installed according to the installation instruction.
- Apply appropriate air pressure (ca. 85% of pump discharge pressure) to the air supply port of the dampener.
- When installation is new or the dampener is reinstalled, a test run with water must be conducted to make sure that the dampener operates normally and does not leak.



- When installation is new or the dampener reinstalled, check the dampener housing nuts tightening torque (see chapter 5.2 "Tightening torques"). After approximately one week of operation, the torque must be checked again. This is important to prevent possible leakage.

#### 2.2. Pressurizing procedure

- Completely close the inlet shut off valve [92].
- Connect the air supply hose to the quick coupling [95].
- Turn on pressure on the air supply line.
- Gently open the shut off valve [92]. Monitor the pressure gauge [91] not to exceed permissible pressure for the particular dampener model.
- Set pressure to 85% of the actual discharge pressure of the pump.
- Close the shut off valve [92].
- After approximately 30 minutes check if the pressure has not dropped. If yes, check the pulsation dampener for any leakage.
- Fine tune the pressure inside the pulsation dampener during pump operation to achieve optimal pulsation reduction.

**Note!** The dampener is equipped with a pressure safety valve that will open automatically when maximum allowable pressure for the particular dampener size is reached.

**Note!** You can check the proper functioning of the pressure safety valve. To do that increase the pressure slightly above the dampener max allowable pressure. The valve should automatically open. If not, do not increase the pressure over, relieve the dampener from pressure and calibrate/replace the pressure safety valve.

#### 2.3. Disposal after expiration of the expected lifetime

Dampener components can be recycled, they must be disposed of properly, according to local regulations. It should be noted that potentially dangerous fluid residues may remain in the dampener and can create a hazard to the operator or the environment, therefore the dampener has to be thoroughly cleaned before disposal.

## 2. OPERATION

---

### 2.4. Actions in emergency



In case of a leakage of an unknown fluid, respiratory protection should be worn and contact with the fluid avoided. During firefighting, no special hazards are to be expected from the dampener itself. In addition, the currently handled fluid and the corresponding safety data sheet must be taken into account. When fluid leakage occurs, the pressure has to be released. During spillage of an aggressive liquid, local and national safety rules must be followed.

### 2.5. Residual risks



Even with proper application and observance of all points listed in this operating manual, there is still an estimable and unexpected residual risk when using the dampeners. It may leak, fail due to wear, application-related causes or system-related circumstances.

## 3. MAINTENANCE

---

### 3. MAINTENANCE



**Maintenance work must be performed by qualified personnel and only when the dampener has been de-pressurized. Follow the local and national safety regulations. Since the dampener is a pressure equipment which falls under the PED Directive, the dampeners can be serviced only by Tapflo Production or an authorized distributor.**

Be careful, if the hose has been broken, the pumped liquid can enter the cavity outside the hose. In such case, the product can escape through the ball valves when de-pressurizing the unit.

Due to the size of some of the dampeners at least two persons should perform maintenance activities and if needed use appropriate lifting devices according to local rules and regulations.

#### 3.1. When the dampener is new or reassembled



**If the dampener is new or reassembled after maintenance it is important to retighten the dampener housing nuts after a week of operation.**

Make sure to use the right torque – see chapter 5.2. *“Tightening torques”*.

#### 3.2. Routine inspection



Frequent observation of the dampener operation is recommended to detect problems. For possible issues see chapter 3.4. *“Location of faults”*.

Leaking liquid from the dampener and changes of performance may also be detected.

We recommend to conduct a daily check and keep records of the following:

- Leakage of fluid from any connection of the dampener
- Tightness of all connection parts of the dampener
- Complete inspection in regular intervals has been done
- Corrosion marks on the dampener

In case any of the above is not fulfilled, do not start the device and implement corrective actions. Establish a preventive maintenance schedule based on the device service history. Scheduled maintenance is especially important to prevent spills or leakage due to diaphragm failure. Although dampener applications vary, a general guideline is to re-torque the nuts every two weeks.

#### 3.3. Complete inspection



The intervals for a complete inspection depend upon the operation conditions of the dampener. The characteristics of the liquid, temperature, materials used in the dampener and running time decide how often a complete inspection is necessary.

If a problem has occurred, or if the dampener is in need of a complete inspection, refer to chapters 3.4 *“Location of faults”* and 3.5 *“Disassembly of the dampener”*. You are of course warmly welcome to consult us for further help.

Parts that are subject to wear should be kept on stock, see our recommendations in chapter 4.3. *“Stocking recommendation”*.

### 3. MAINTENANCE

#### 3.4. Location of faults

PROBLEM	POSSIBLE FAULT	POSSIBLE SOLUTION
<b>The dampener does not work</b>	The air pressure is too low	Check if set pressure is ca. 85% of the pump discharge pressure
	The air connection is blocked	Check / clean air supply connection
	The dampener is installed too far from the pump	The closer the dampener is to the pump the better, no further than 5 times the pipeline diameter
	Too slow pump operation	Increase pumping speed
	Lack of counter pressure (free flow operation)	Increase counter pressure
	Dirt in the dampener chamber	Remove debris from the chambers
	Hose breakdown	Replace hose
<b>Liquid leaks from the dampener</b>	Screws on the housing not properly tightened	Check tightening torques of the screws
	Damaged hose	Check / replace hose
	Tension / stress from the installation	Adjust installation, eliminate stress, provide separate support for dampener
<b>Hose breakdown</b>	Wrong selection of material	Contact us for information on material selection
	Too high pressure in the installation	Use pressure regulator for protection
<b>Pressure leak from dampener</b>	Damaged seal	Check and replace the seal if necessary
	Screws on the housing not properly tightened	Check tightening torques of the screws

# 3. MAINTENANCE

## 3.5. Disassembly of the dampener

The numbers put in brackets, refer to the part numbers in the spare part drawings and spare part lists in chapter 4 "Spare parts".

### 3.5.1. Before the disassembly procedure



The disassembly should be performed only by qualified personnel. There should always be at least two persons present during disassembly.



Disconnect the air supply and then the suction and discharge connections. Before servicing in any way the parts that come in contact with the pumped liquid, make sure that the dampener has been fully emptied and washed. When draining the liquid, make sure that there is no danger for people or the environment.

### 3.5.2. Disassembly procedure

<p><b>Fig. 3.6.1</b> Unscrew the drain/vent ball valve [93].</p>	<p><b>Fig. 3.6.2</b> Unscrew the cover mounting bolts [901] and remove them with their washers [902].</p>
<p><b>Fig. 3.6.3</b> Remove the pneumatic fittings cover [90] from the dampener.</p>	<p><b>Fig. 3.6.4</b> Remove the pneumatic fittings from the dampener.</p>

### 3. MAINTENANCE

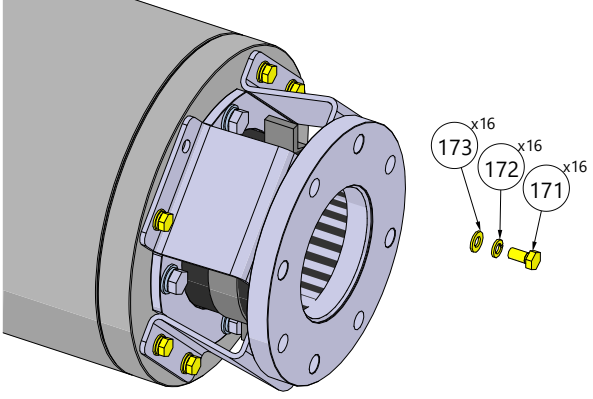
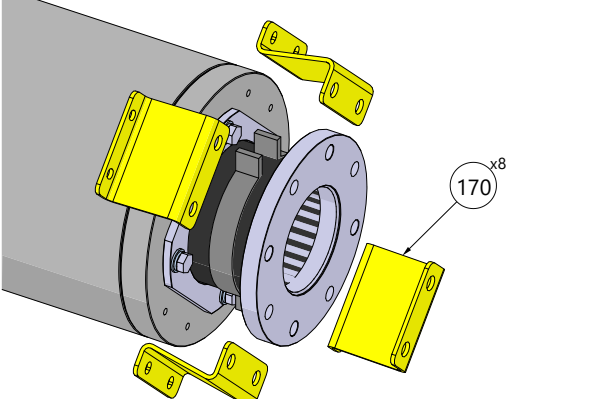
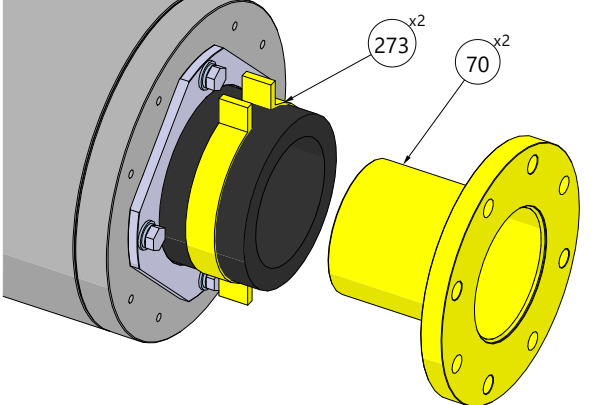
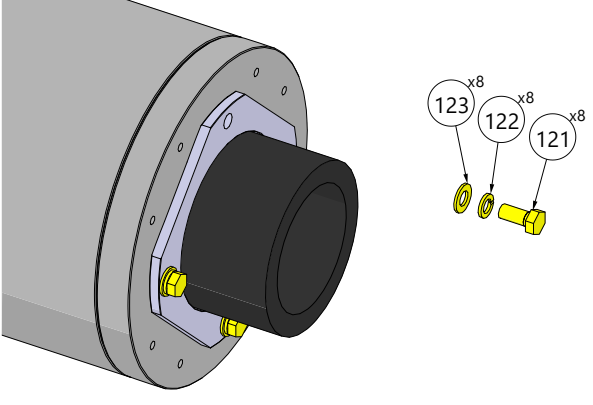
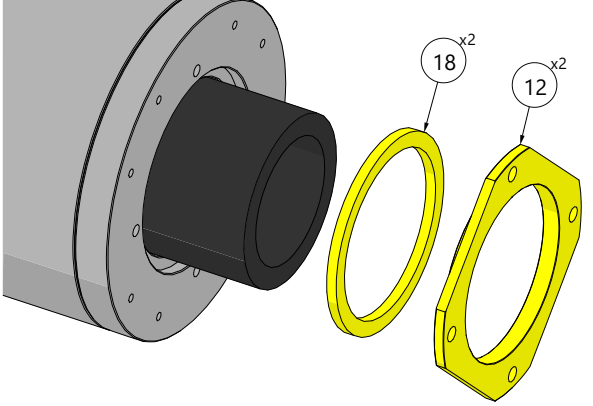
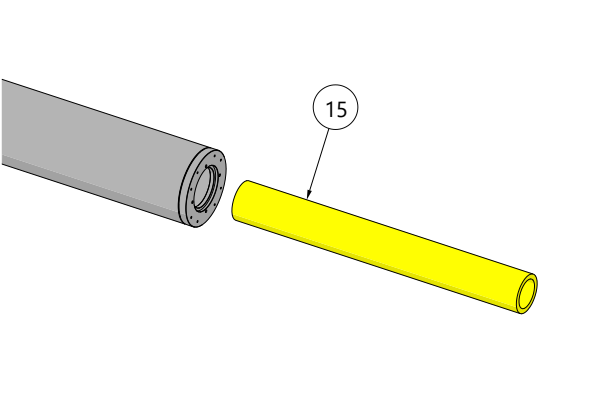
	
<p><b>Fig. 3.6.5</b> Unscrew the bracket mounting bolts [171] and remove them with their washers [172] [173] from both sides of the dampener.</p>	<p><b>Fig. 3.6.6</b> Remove brackets [170] from both sides of the dampener.</p>
	
<p><b>Fig. 3.6.7</b> Unscrew the clamps [273] and remove the inserts [70] from both sides of the dampener.</p>	<p><b>Fig. 3.6.8</b> Unscrew the seal cover mounting bolts [121] and remove them with their washers [122] [123] from both sides of the dampener.</p>
	
<p><b>Fig. 3.6.9</b> Remove the seal cover [12] and the rubber seal [18] from both sides of the dampener.</p>	<p><b>Fig. 3.6.10</b> Remove the hose [15] from the dampener.</p>

The dampener is now completely disassembled. Check all components for wear or damage and replace if necessary.

## 3. MAINTENANCE

---

### 3.6. Assembly of the dampener

The assembly procedure is done in the reverse order to the disassembly.  
Please remember to seal all pneumatic connection by means of PTFE tape.

#### 3.6.1. Test run



We recommend you to conduct a test of the dampener before installing it in the system, to detect if there is no air leakage through diaphragm shaft. In order to do so, supply pressurized air through air inlet. Proper operation is, when there is no continuous air flow through the muffler.

Note! Due to its principle of operation, when supplied with pressurized air, shaft may perform one stroke, resulting in short air release through muffler, which is not considered as a leakage.

**After one week of operation retighten the nuts with appropriate torque.**

# 4. SPARE PARTS

## 4. SPARE PARTS

### 4.1. Exploded view

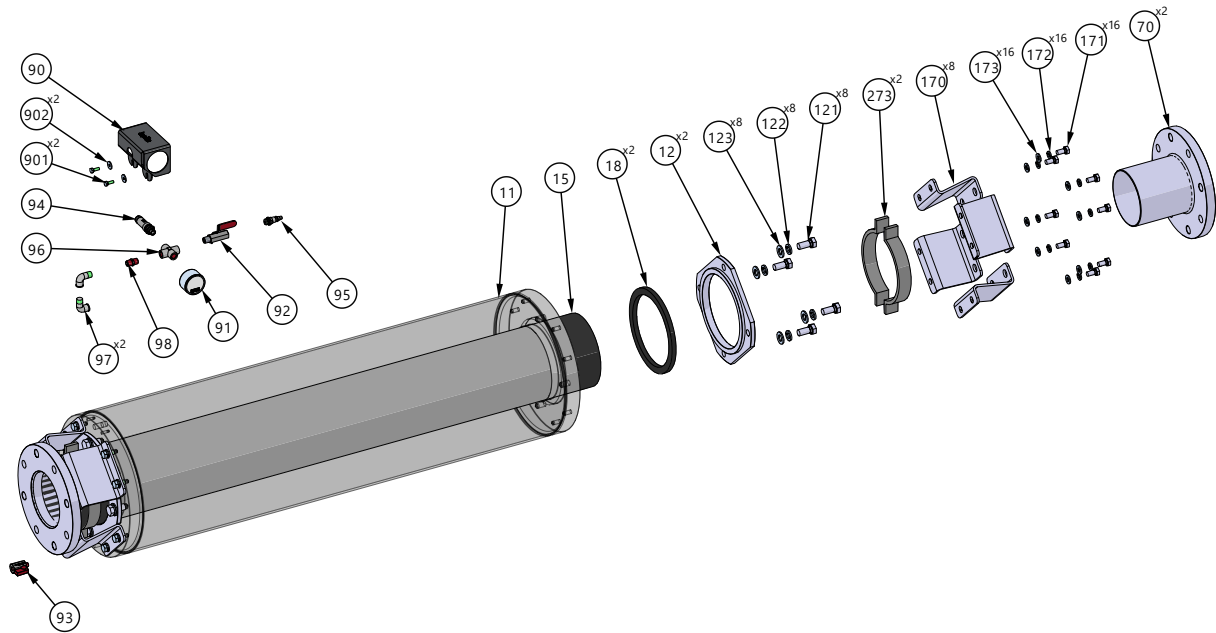

For interactive exploded view go [HERE](#)

### 4.2. Spare parts list

Pos.	Q-ty	Description	Material
11	1	Housing	AISI 304L
12	2	Seal cover	AISI 304L
15	1	Hose	NR, NBR, EPDM, NR FDA, NBR FDA, EPDM FDA, CSM
18	1	Seal	NBR
70	2	Connection insert	AISI 316L, PTFE lined AISI 316L
90	1	Pneumatic fittings cover	AISI 304
91	1	Pressure gauge	Various
92	1	Inlet ball valve	Nickel plated brass
93	1	Drain/vent ball valve	Nickel plated brass
94	1	Pressure safety valve	Brass
95	1	Air connection quick coupling	Brass
96	1	Cross fitting	Nickel plated brass
97	2	Elbow	Nickel plated brass
98	1	Threaded nipple	Nickel plated brass
170	4/8 <sup>1)</sup>	Flange bracket	AISI 316L
171	8/16 <sup>2)</sup>	Flange bracket mounting bolt	A4-70
172	8/16 <sup>2)</sup>	Flange bracket mounting spring washer	A4-70
173	0/16 <sup>3)</sup>	Flange bracket mounting washer	A4-70
121	8	Seal cover mounting bolt	A4-70
122	8	Seal cover mounting spring washer	A4-70
123	0/8 <sup>4)</sup>	Seal cover mounting washer	A4-70
273	2	Hose clamp	Cast Iron
901	2	Cover mounting bolt	A4-70
902	2	Cover mounting washer	A4-70

1) **4** for DPT40 / **8** for DPT65-DPT125

2) **8** for DPT40 / **16** for DPT65-DPT125

3) **0** for DPT40 / **16** for DPT65-DPT125

4) **0** for DPT40 / **8** for DPT65-DPT125

## 4. SPARE PARTS

### 4.3. Stocking recommendation

Even at normal operation some elements in the dampener will be worn. In order to avoid expensive breakdowns we recommend having a few spare parts in stock.

Pos.	Description	Quantity
15	Hose	2-3*
18	Gasket	2

\* Depending on the application conditions it is recommended to keep 2 to 3 hoses on stock.

### 4.4. How to order parts

When ordering spare parts for Tapflo dampeners, please let us know what is the **model number** (see nameplate) and **serial number** (visible on nameplate). Then just indicate the part numbers from the spare parts list and quantity of each item.

### 4.5. Dampener code

The model number on the dampener and on the front page of this instruction manual tells the dampener size and materials of the dampener.

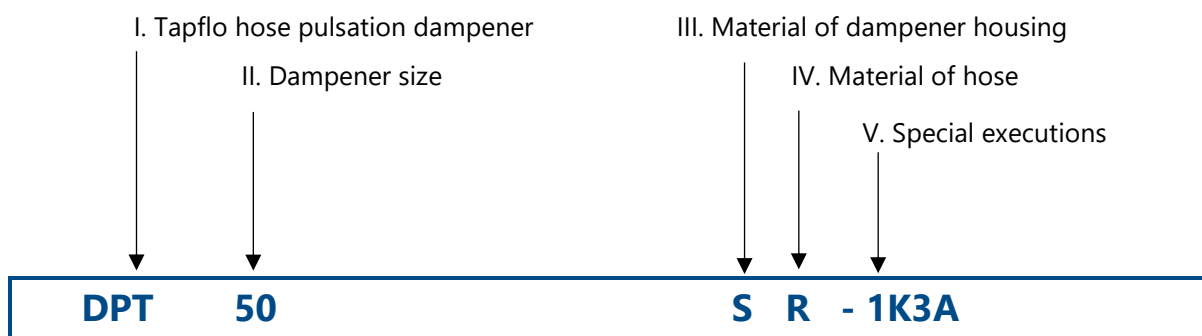

**I. DT = Tapflo active pulsation dampener**

**II. Dampener size:**

- 40 = For PT25, PT32, PT40 and PTX40
- 50 = For PT50, PT65 and PTX65
- 100 = For PTX80, PT80 and PT100
- 125 = For PT125

**III. Material of dampener housing:**

- S = AISI 304

**IV. Material of hose:**

- R = NR
- E = EPDM
- N = NBR
- S = NR FDA
- W = EPDM FDA
- F = NBR FDA
- C = CSM

**V. Special executions:**

- 1 = Optional in/outlet material
- blank = AISI 316L
- ST = PTFE lined AISI 316L
- 3 = Optional connections

# 5. DATA

## 5. DATA

### 5.1. Overall dimensions

Dimensions in mm (where other is not indicated)

Dimensions in inch (where other is not indicated)

General dimensions only, ask us for detailed drawings. Changes reserved without notice.

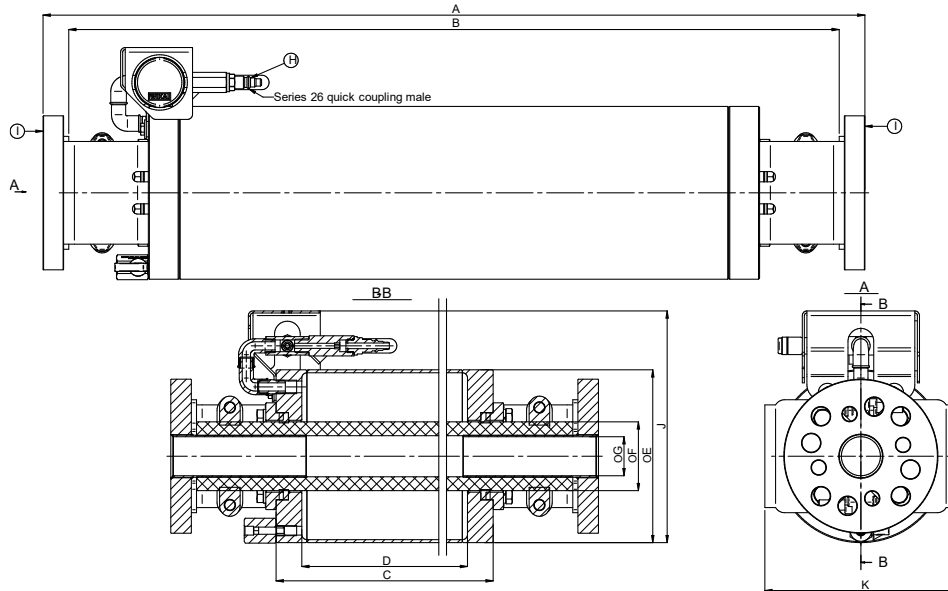

	DAMPENER SIZE			
	DPT40	DPT65	DPT100	DPT125
<b>A</b>	800	962	1370	1370
	31.5	37.87	53.94	53.94
<b>B</b>	750	900	1320	1320
	29.53	35.43	51.97	51.97
<b>C</b>	595	720	1125	1125
	23.43	28.35	44.29	44.29
<b>D</b>	545	660	1065	1065
	21.46	25.98	41.93	41.93
<b>E</b>	168	273	324	324
	6.61	10.75	12.76	12.76
<b>F</b>	67	80	144	168
	2.64	3.15	5.67	6.61
<b>G</b>	38	49	100	125
	1.50	1.93	3.94	4.92
<b>H</b>	DN 7.2	DN7.2	DN7.2	DN7.2
	-	-	-	-
<b>I</b>	DN25-40	DN50-65	DN80-100	DN125
	-	-	-	-
<b>J</b>	226	336	386	386
	8.90	13.23	15.20	15.20
<b>K</b>	187	273	324	324
	7.36	10.75	12.76	12.76

# 5. DATA

## 5.2. Tightening torques

Checking of the tightening torques is necessary after all periods of stoppage, when temperature variations are a factor and after all transport and maintenance of the dampener. What is more, for proper operation and safety the torque values should be checked frequently as part of preventive maintenance (please contact Tapflo for interval proposals). Although applications vary, a general guideline is to re-torque the dampener every two weeks.

Bolt pos.	Torque and size			
	DPT40	DPT65	DPT100	DPT125
121	M10	M12	M14	M14
	<b>30 Nm</b>	<b>55 Nm</b>	<b>80 Nm</b>	<b>80 Nm</b>
171	M10	M10	M10	M10
	<b>30 Nm</b>	<b>30 Nm</b>	<b>30 Nm</b>	<b>30 Nm</b>
901	M6	M6	M6	M6
	<b>6 Nm</b>	<b>6 Nm</b>	<b>6 Nm</b>	<b>6 Nm</b>

For routine inspection and maintenance schedule see chapter 3.2. "Routine inspection" and 3.3. "Complete inspection".

**Although applications vary, a general guideline is to re-torque the dampener every two weeks.**

## 5.3. Technical data

TECHNICAL DATA	DAMPENER SIZE			
	DPT40	DPT65	DPT100	DPT125
Max air pressure [bar] / [psi]	15 / 217	10 / 145	10 / 145	10 / 145
PN @ 20 °C [bar] / [psi]	15 / 217	10 / 145	10 / 145	10 / 145
Max temp [°C] / [°F]	80 / 176	80 / 176	80 / 176	80 / 176
Min temp in SS [°C] / [°F]	-20 / -4	-20 / -4	-20 / -4	-20 / -4
Weight in SS [kg] / [lb]	28 / 62	64 / 141	104 / 229	103 / 227
Internal volume [dm <sup>3</sup> ] / [gal(US)]	13 / 3.43	36 / 9.51	83 / 21.93	88 / 23.25

COMPONENT	MATERIAL
Housing (not wetted)	AISI 304L
Seal cover (not wetted)	AISI 304L
Hose (wetted)	NR, NR FDA, NBR, NBR FDA, EPDM, EPDM FDA, CSM
Flange bracket (not wetted)	AISI 316L
In/outlet (wetted)	AISI 316L, PTFE lined AISI 316L
Fasteners	A4-70

# 5. DATA

## 5.4. Permitted loads on manifolds

We recommend not to exceed the following loads and forces reacting on the manifolds.

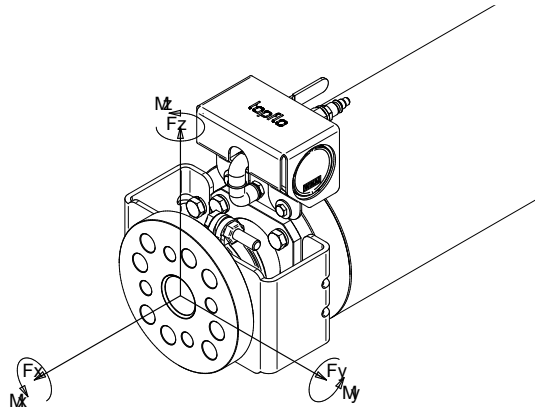

		DN40	DN50	DN100	DN125
<b>DIN 1092-1</b> <b>Flange connection</b>	$F_x$ [N]	<b>1540</b>	<b>3810</b>	<b>3170</b>	<b>4160</b>
	$F_y$ [N]	<b>290</b>	<b>1230</b>	<b>1600</b>	<b>1620</b>
	$F_z$ [N]	<b>500</b>	<b>1210</b>	<b>1580</b>	<b>1640</b>
	$M_x$ [Nm]	<b>120</b>	<b>295</b>	<b>200</b>	<b>420</b>
	$M_y$ [Nm]	<b>55</b>	<b>155</b>	<b>215</b>	<b>220</b>
	$M_z$ [Nm]	<b>35</b>	<b>160</b>	<b>215</b>	<b>230</b>
<b>DIN 11851</b> <b>Threaded connection</b>	$F_x$ [N]	<b>250</b>	<b>590</b>	<b>900</b>	<b>1280</b>
	$F_y$ [N]	<b>310</b>	<b>310</b>	<b>570</b>	<b>1280</b>
	$F_z$ [N]	<b>280</b>	<b>310</b>	<b>620</b>	<b>1220</b>
	$M_x$ [Nm]	<b>70</b>	<b>115</b>	<b>180</b>	<b>335</b>
	$M_y$ [Nm]	<b>35</b>	<b>50</b>	<b>95</b>	<b>180</b>
	$M_z$ [Nm]	<b>35</b>	<b>50</b>	<b>90</b>	<b>175</b>
<b>DIN 32676</b> <b>Clamp connection</b>	$F_x$ [N]	<b>250</b>	<b>500</b>	<b>700</b>	<b>1280</b>
	$F_y$ [N]	<b>250</b>	<b>300</b>	<b>570</b>	<b>1090</b>
	$F_z$ [N]	<b>250</b>	<b>270</b>	<b>570</b>	<b>1180</b>
	$M_x$ [Nm]	<b>75</b>	<b>115</b>	<b>205</b>	<b>255</b>
	$M_y$ [Nm]	<b>35</b>	<b>50</b>	<b>95</b>	<b>175</b>
	$M_z$ [Nm]	<b>35</b>	<b>50</b>	<b>95</b>	<b>180</b>

# 6. WARRANTY

## 6. WARRANTY

### 6.1. Warranty form

Company:	_____
Telephone:	_____ Fax: _____
Address:	_____
Country:	_____ Contact Name: _____
E-mail:	_____
Delivery Date:	_____ Date of dampener installation: _____
Dampener type:	_____
Serial No (see name plate or stamped on dampener housing):	_____
Description of the fault:	_____ _____ _____
<b>The installation:</b>	
Liquid:	_____
Temperature [°C]: _____	Viscosity [cPs]: _____ Spec grav. [kg/m <sup>3</sup> ]: _____ pH-value: _____
Content of particles: _____	% of max size [mm]: _____
Flow [l/min]: _____	Duty [h/day]: _____ No of starts per day: _____
Liquid pressure [bar]: _____	_____
Air pressure [bar]: _____	Quality of the air (filter, micron, lubrication): _____
Other:	_____ _____
<b>Place for sketch of installation:</b>	

## 6. WARRANTY

---

### 6.2. Returning parts

When returning parts to Tapflo please follow this procedure:

- Consult Tapflo for shipping instructions.
- Cleanse or neutralize and rinse the part/dampener. Make sure the part/dampener is completely empty from liquid.
- Pack the return articles carefully to prevent any damage during transportation.

***Goods will not be accepted unless the above procedure has been complied with.***

### 6.3. Warranty

Tapflo warrants products under conditions as stated below for a period of not more than 5 years from installation and not more than 6 years from date of manufacturing.

1. The following terms and conditions apply to the sale of machinery, components and related services and products, of Tapflo (hereinafter "the products").
2. Tapflo (the manufacturer) warrants that:
  - a. its products are free of defects in material, design and workmanship at the time of original purchase;
  - b. its products will function in accordance with Tapflo operative manuals; Tapflo does not guarantee that the product will meet the precise needs of the Customer, except for those purposes set out in any invitation to render documents or other documents specifically made available to Tapflo before entering into this agreement;
  - c. high quality materials are used in the construction of the dampeners and that machining and assembly are carried out to the highest standards.

Except as expressly stated above, Tapflo makes no warranties, express or implied, concerning the products, including all warranties of fitness for a particular purpose.

3. This warranty shall not be applicable in circumstances other than defects in material, design, and workmanship. In particular warranty shall not cover the following:
  - a. Periodic checks, maintenance, repair and replacement of parts due to normal wear and tear (seals, O-rings, rubber items, diaphragms, air valves etc.);
  - b. Damage to the product resulting from:
    - b.1. Tampering with, abuse or misuse, including but not limited to failure to use the product for its normal purposes as stated at the time of purchase or in accordance with Tapflo instructions for use and maintenance of the product, or the installation or improper ventilation or use of the product in a manner inconsistent with the technical or safety standard in force;
    - b.2. Repairs performed by unauthorized personnel, without consent of Tapflo, or use of non-original Tapflo parts;

## 6. WARRANTY

---

- b.3. Accidents or any cause beyond the control of Tapflo, including but not limited to lightning, water, fire, earthquake, and public disturbances, etc.;
4. The warrantee shall cover the replacement or repairing of any parts, which is documented faulty due to construction or assembling, with new or repaired parts free of charges delivered by Tapflo. Parts subjected to normal tear and wear shall not be covered by the warranty. Tapflo shall decide as to whether the defective or faulty part shall be replaced or repaired.
  5. The warrantee of the products shall be valid for a period in accordance to the current law from the date of delivery, under the condition that notice of the alleged defect to the products or parts thereof be given to Tapflo in written within the mandatory term of 8 days from the discovery. Repair or replacement under the terms of this warranty shall not give a right to an extension to, or a new commencement of, the period of warranty.
  6. Repair or replacement under the terms of this warranty shall not give a right to an extension to, or a new commencement of, the period of warranty. Repair or replacement under the terms of this warranty may be fulfilled with functionally equivalent reconditioned units. Tapflo qualified personnel shall be solely entitled to carry out repair or replacement of faulty parts after careful examination of the dampener. Replaced faulty parts or components will become the property of Tapflo.
  7. The products are built in accordance with standard CE normative and are tested (where applicable) by Tapflo. Approval and tests by other control authority are for the customer's account. The products shall not be considered defective in materials, design or workmanship if they need to be adapted, changed or adjusted to conform to national or local technical or safety standards in force in any country other than that for which the unit was originally designed and manufactured. This warranty shall not reimburse such adaptations, changes or adjustments, or attempt to do so, whether properly performed or not, nor any damage resulting from them, nor any adaptation, change or adjustments to upgrade the products from their normal purpose as described in the products operative manual without the prior written consent of Tapflo.
  8. Installation, including electric and other connections to utility mains according to Tapflo drawings, is for the cost and responsibility of the customer, unless otherwise agreed in writing.
  9. Tapflo will not be liable on any claim, whether in contract, tort, or otherwise, for any indirect, special, incidental, or consequential damages, caused to the customer or to third parties, including loss of profits, arising by any possible infringement of par. 3 above or by the customer or third parties being in the impossibility of using the products.

Steady the above, Tapflo liability to the customer or third parties from any claim, whether in contract, tort, or otherwise, shall be limited to the total amount paid by the customer for the product that caused the damages.

## Sweden

Filaregatan 4 | S-442 34 Kungälv

Tel: +46 303 63390

Fax: +46 303 19916

E-mail addresses:

Commercial questions: [sales@tapflo.com](mailto:sales@tapflo.com)

Orders: [order@tapflo.com](mailto:order@tapflo.com)

Tech support: [support@tapflo.com](mailto:support@tapflo.com)

## Tapflo products and services are available worldwide.

Tapflo is represented by own Tapflo Group Companies and carefully selected distributors assuring highest Tapflo service quality for our customers' convenience.

AUSTRALIA | AUSTRIA | AZERBAIJAN | BAHRAIN | BELGIUM | BOSNIA | BRAZIL | BULGARIA | CANADA | CHILE | CHINA | COLOMBIA | CROATIA | CZECH REPUBLIC | DENMARK | ECUADOR | EGYPT | ESTONIA | FINLAND | FRANCE | GEORGIA | GERMANY | GREECE | HONG-KONG | HUNGARY | ICELAND | INDIA | INDONESIA | IRELAND | ISRAEL | ITALY | JAPAN | JORDAN | KAZAKHSTAN | KUWAIT | LATVIA | LIBYA | LITHUANIA | MACEDONIA | MALAYSIA | MEXICO | MONTENEGRO | MOROCCO | NETHERLANDS | NEW ZEALAND | NORWAY | OMAN | PHILIPPINES | POLAND | PORTUGAL | QATAR | ROMANIA | SAUDI ARABIA | SERBIA | SINGAPORE | SLOVAKIA | SLOVENIA | SOUTH AFRICA | SOUTH KOREA | SPAIN | SWEDEN | SWITZERLAND | TAIWAN | THAILAND | TURKEY | UKRAINE | UNITED ARAB EMIRATES | UNITED KINGDOM | USA | UZBEKISTAN | VIETNAM

## Tapflo Group Companies

### Australia

Tapflo Oceania (Pty) Ltd.  
Tel: +61 1800303633  
[sales@tapflo.com.au](mailto:sales@tapflo.com.au)

### China

Tapflo (Wuxi) Pumps Co. Ltd.  
Tel: +86 51082417072  
[sales@tapflo.cn](mailto:sales@tapflo.cn)

### Ireland

Tapflo Ireland Ltd.  
Tel: +353 12011911  
[info@tapflo.ie](mailto:info@tapflo.ie)

### Poland

Tapflo Sp. z o.o.  
Tel: +48 609 995 500  
[info@tapflo.pl](mailto:info@tapflo.pl)

### Spain

Tapflo Ibérica S.L.  
Tel: +34 918093182  
[avives@tapfloiberica.es](mailto:avives@tapfloiberica.es)

### Uzbekistan

Tapflo Uzbekistan  
Tel: +998 712370940  
[sales@tapflo.uz](mailto:sales@tapflo.uz)

### Austria

Tapflo GmbH  
Tel: +43 73227292910  
[sales@tapflo.at](mailto:sales@tapflo.at)

### Croatia

Tapflo d.o.o.  
Tel: +385 914884666  
[sales@tapflo.hr](mailto:sales@tapflo.hr)

### Italy

Tapflo Italia S.r.l.  
Tel: +39 0362306528  
[info@tapfloitalia.com](mailto:info@tapfloitalia.com)

### Qatar

Tapflo Gulf General Trading Co. L.L.C  
Tel: +971 58 582 3630  
[sales@tapfloqulf.com](mailto:sales@tapfloqulf.com)

### South Africa

Tapflo (Pty) Ltd.  
Tel: +27 317015255  
[sales@tapflo.co.za](mailto:sales@tapflo.co.za)

### Bahrain

Tapflo Gulf General Trading Co. L.L.C  
Tel: +971 58 582 3630  
[sales@tapfloqulf.com](mailto:sales@tapfloqulf.com)

### Czech Republic

Tapflo s.r.o.  
Tel: +420 513033920  
[tapflo@tapflo.cz](mailto:tapflo@tapflo.cz)

### Japan

Tapflo Japan K.K.  
Tel: +81 362403510  
[tapflojp@tapflo.co.jp](mailto:tapflojp@tapflo.co.jp)

### Romania

S.C. Tapflo Rom. S.r.l.  
Tel: +40 213451255  
[sales@tapflo.ro](mailto:sales@tapflo.ro)

### Sweden

Tapflo AB Tel: +46  
(0)30314050 [info@tapflo.com](mailto:info@tapflo.com)

### Baltic States

Tapflo SIA  
Tel: +371 67472205  
[sales@tapflo.lv](mailto:sales@tapflo.lv)

### Denmark

Tapflo Danmark ApS  
Tel: +45 36454600  
[info@tapflo.dk](mailto:info@tapflo.dk)

### Kazakhstan

Tapflo LLP  
Tel: +7 727 327 83 47  
[sales@tapflo.kz](mailto:sales@tapflo.kz)

### Saudi Arabia

Tapflo Gulf General Trading Co. L.L.C  
Tel: +971 58 582 3630  
[sales@tapfloqulf.com](mailto:sales@tapfloqulf.com)

### Turkey

Tapflo Makina Ltd.  
Tel: +90 2164673311  
[sales@tapflo.com.tr](mailto:sales@tapflo.com.tr)

### Belgium

Tapflo Benelux B.V.  
Tel: +31 (0) 6 21850664  
[info@tapflo.nl](mailto:info@tapflo.nl)

### France

Sarl Tapflo France  
Tel: +33188788240  
[info@tapflo.fr](mailto:info@tapflo.fr)

### Kuwait

Tapflo Gulf General Trading Co. L.L.C  
Tel: +971 58 582 3630  
[sales@tapfloqulf.com](mailto:sales@tapfloqulf.com)

### Serbia

Tapflo d.o.o.  
Tel: +381 21445808  
[sales@tapflo.rs](mailto:sales@tapflo.rs)

### Ukraine

Tapflo LLC  
Tel: +380 442226844  
[sales@tapflo.ua](mailto:sales@tapflo.ua)

### Bulgaria

Tapflo EOOD  
Tel: +359 886 124 937  
[office@tapflo.bg](mailto:office@tapflo.bg)

### Hungary

Tapflo Kft.  
Tel: +36 30148 8551  
[office@tapflo.hu](mailto:office@tapflo.hu)

### Netherlands

Tapflo Benelux B.V.  
Tel: +31 (0) 6 21850664  
[info@tapflo.nl](mailto:info@tapflo.nl)

### Slovakia

Tapflo s.r.o.  
Tel: +421 911137883  
[tapflo@tapflo.sk](mailto:tapflo@tapflo.sk)

### Canada

Tapflo Canada  
Tel: +1 514 409 8380  
[office@tapflo.ca](mailto:office@tapflo.ca)

### India

Tapflo Fluid Handling India Pvt Ltd.  
Tel: +91 9028574063  
[enquiry@tapflo.in](mailto:enquiry@tapflo.in)

### Oman

Tapflo Gulf General Trading Co. L.L.C  
Tel: +971 58 582 3630  
[sales@tapfloqulf.com](mailto:sales@tapfloqulf.com)

### Slovenia

Tapflo d.o.o.  
Tel: +386 68613474  
[sales@tapflo.hr](mailto:sales@tapflo.hr)

### United Arab Emirates

Tapflo Gulf General Trading Co. L.L.C  
Tel: +971 58 582 3630  
[sales@tapfloqulf.com](mailto:sales@tapfloqulf.com)

### United Kingdom

Tapflo (UK) Ltd.  
Tel: +44 2380252325  
[sales@tapflo pumps.co.uk](mailto:sales@tapflo pumps.co.uk)



If your country is not listed please visit [www.tapflo.com/en/contact](http://www.tapflo.com/en/contact)