

IOM manual

tapflo®

PT High Pressure Hose Pumps

Original Instruction
2023 | rev.1



Read this instruction manual carefully,
before you install and operate the pump



Pump models:

PT/PXT
5
10
15
20
25
32
38
40
51
60
65
80
80L
100
125



» All about your flow™

www.tapflo.com

CONTENTS

EC DECLARATION OF CONFORMITY 01/EU/PT/2023	5
EU DECLARATION OF CONFORMITY 01/ATEX/PXT/HEAD/2023	6
EU DECLARATION OF CONFORMITY 01/ATEX/PXT/2023	7
0. GENERAL	8
0.1. Introduction	8
0.2. Warning symbols	8
0.3. Qualification and training of personnel	8
0.4. Nameplate	9
1. INSTALLATION	10
1.1. Operation principle	10
1.2. Receiving inspection	10
1.3. Lifting and transportation	10
1.4. Storage	11
1.5. Foundation	11
1.6. Environment	11
1.7. Suction and discharge piping	11
1.7.1. Connection of suction pipe	12
1.7.2. Connection of discharge pipe	12
1.8. Health and safety	12
1.8.1. Protection	12
1.8.2. Electrical safety	12
1.8.3. Potentially explosive atmospheres – ATEX	13
.....	13
1.8.4. Chemical hazard	13
1.8.5. Noise level	13
1.8.6. Temperature hazards	13
1.8.7. Rotating parts	14
1.8.8. Cleaning and disinfection	14
1.9. Installation recommendations	14
1.9.1. Minimum required distance for hose removal	14
1.10. Instruments	15
1.10.1. Electric power	15
1.10.2. Optional instruments	15
1.10.3. Thermometer	15

CONTENTS

1.10.4. Pressure safety device	15
1.11. Motor connection	16
1.12. Gear-motor standard	16
2. OPERATION	17
2.1. Before starting the pump	17
2.2. Starting and operation	17
2.2.1. Dry running	18
2.2.2. Dead head	18
2.2.3. Optimization of the pump lifetime	18
2.3. Pump stopping	18
2.4. Cleaning and disinfection	18
2.5. Residual risks	19
2.6. Disposal after expiration of the expected lifetime	19
2.7. Waste of electrical and electronic equipment (WEEE) directive	19
2.8. Actions in emergency	19
3. MAINTENANCE	20
3.1. Inspections	20
3.2. When the pump is new or reassembled	20
3.2.1. Performance test	20
3.3. Routine inspection	20
3.4. Complete inspection	21
3.5. Location of faults	21
3.6. Disassembly of the pump	22
3.6.1. Before the disassembly procedure	22
3.6.2. Disassembly procedure	22
3.6.3. Test run	26
3.7. Casing emptying and lubricant filling procedure	27
3.8. Hose cleaning	29
3.9. Hose replacement	29
3.10. Pump casing cleaning procedure	33
3.11. Shoe shimming – PT25 – PT125	35
3.12. Rotor/shoe assembly	37
3.13. Casing assembly directions	38
4. OPTIONS AND ACCESSORIES	39
4.1. Clean PRO PUMP	39
4.2. Pump trolleys	39

CONTENTS

4.3.	Frequency inverters	39
4.4.	Hose leak detector	39
5.	SPARE PARTS	40
5.1.	Exploded view PT5 – PT20	40
5.2.	Spare parts list PT5 – PT20	40
5.3.	Spare parts KITS PT5 – PT20	41
5.3.1.	Complete clamping set for PT5-PT20 – 15-020-16S	41
5.4.	Exploded view PT25 – PT38	42
5.5.	Spare parts list PT25 – PT38	42
5.6.	Spare parts KITS PT25 – PT38	43
	Complete clamping set for PT25 – 15-025-16S	43
	Complete clamping set for PT32-PT38 – 15-038-16S	43
5.7.	Exploded view PT40 – PT60	44
5.8.	Spare parts list PT40 – PT60	44
5.9.	Spare parts KITS PT40 – PT60	45
	Complete clamping set for PT40 – 15-040-16S	45
	Complete clamping set for PT51-PT60 – 15-060-16S	45
5.10.	Exploded view PT65 – PT80L	46
5.11.	Spare parts list PT65 – PT80L	46
5.12.	Exploded view PT100	48
5.13.	Spare parts list PT100	48
5.14.	Exploded view PT125	50
5.15.	Spare parts list PT125	50
5.16.	Exploded view PTC40	52
5.17.	Spare parts list PTC38-40	52
5.18.	Exploded view rotor PTC38-40	53
5.19.	Spare parts list rotor PTC40	53
5.20.	Stocking recommendation	54
5.21.	How to order parts	55
5.22.	Pump code	55
5.23.	Obsolete codification	56
6.	DATA	57
6.1.	Capacity curves	57
6.2.	Technical data	59
6.3.	Shimming tables	60
6.4.	Dimensions	60

CONTENTS

6.4.1.	PT5 – PT20	61
6.4.2.	PT25 – PT80	62
6.4.3.	PT80L – PT125	63
6.5.	Tightening torques	64
6.6.	Permitted loads on manifolds.....	65
7.	ATEX supplementary manual	66
7.1.	Potentially explosive atmospheres - ATEX	66
7.2.	Operating limits	66
7.3.	Construction materials use restrictions.....	67
7.4.	Pumped liquids	68
7.5.	Installation, operation and maintenance.....	68
7.6.	Spares.....	68
7.7.	Lubricant.....	68
7.8.	Hose leak detector	68
7.9.	Temperature sensor	70
7.10.	Casing and front cover positions.....	72
7.11.	Shoe shimming.....	74
7.12.	Rotor assembly.....	74
7.13.	Foreign objects in pump casing.....	74
7.14.	Dry run	74
7.15.	Closed-circuit operation	74
7.16.	High negative suction pressure	74
7.17.	Drive	75
7.18.	Earth connection of the pump and other equipment.....	75
7.19.	Antistatic surface	75
7.20.	Paint thickness	75
7.21.	Inspection	75
8.	WARRANTY	76
8.1.	Warranty form.....	76
8.2.	Returning parts	77
8.3.	Warranty.....	77

EC DECLARATION OF CONFORMITY 01/EU/PT/2023

Series:

**PT(...)5...; PT(...)10...; PT(...)15...; PT(...)20...; PT(...)25...; PT(...)32...; PT(...)38...; PT(...)40...;
PT(...)51...; PT(...)60...; PT(...)65...; PT(...)80...; PT(...)80L...; PT(...)100...; PT(...)125...;**

Manufactured by Tapflo Sp. z o.o., Poland for:

Tapflo Group AB

Filaregatan 4

442 34 Kungälv, Sweden

This declaration of conformity is issued under the sole responsibility of the manufacturer.

Object of declaration: **HIGH PRESSURE HOSE PUMPS**

The object of the declaration described above is in conformity with the relevant Union harmonisation legislation:

- Directive 2006/42/EC of European Parliament and of the Council of 17 May 2006 on machinery, amending Directive 95/16/EC;
- Directive 2014/30/EU of the European Parliament and of the Council of 26 February 2014 on the harmonisation of the laws of the Member States relating to electromagnetic compatibility (recast);
- Directive 2014/35/EU of the European Parliament and of the Council of 26 February 2014 on the harmonisation of the laws of the Member States relating to the making available on the market of electrical equipment designed for use within certain voltage limits;



Signed for and on behalf of Tapflo Group AB

A handwritten signature in black ink, appearing to read 'Per Antonsson', written over a white background.

Per Antonsson
Chief Executive Officer
Kungälv, 01.06.2023

EU DECLARATION OF CONFORMITY 01/ATEX/PXT/HEAD/2023

Series:

PXT(...)5...; **PXT(...)**10...; **PXT(...)**15...; **PXT(...)**20...; **PXT(...)**25...; **PXT(...)**32...; **PXT(...)**38...;
PXT(...)40...; **PXT(...)**51...; **PXT(...)**60...; **PXT(...)**65...; **PXT(...)**80...; **PXT(...)**80L...;
PXT(...)100...; **PXT(...)**125...;

Manufactured by Tapflo Sp. z o.o., Poland for:

Tapflo Group AB

Filaregatan 4

442 34 Kungälv, Sweden

This declaration of conformity is issued under the sole responsibility of the manufacturer.

Object of declaration: **HIGH PRESSURE HOSE PUMP HEADS DESIGNED FOR USE IN POTENTIALLY EXPLOSIVE ATMOSPHERES**

The object of the declaration described above is in conformity with the relevant Union harmonisation legislation:

- Directive **2006/42/EC** of European Parliament and of the Council of 17 May 2006 on machinery
- Directive **2014/34/EU** of the European parliament and of the council of 26 February 2014 on Equipment or Protective System intended for use in potentially explosive atmospheres

Applied harmonised standards:

- **EN ISO 80079-36:2016-07**
- **EN ISO 80079-37:2016-07**

ATEX marking:

  **II 2G Ex h IIB T4 Gb**
II 2D Ex h IIIC T125°C Db

Notified body **J.S. Hamilton Poland Sp. z o.o.** performed **type examination** and issued certificate **JSHP 23 ATEX 0018X**

Signed for and on behalf of Tapflo Group AB



Per Antonsson

Chief Executive Officer

Kungälv, 09.08.2023

EU DECLARATION OF CONFORMITY 01/ATEX/PXT/2023

Series:

**PXT(...)5...; PXT(...)10...; PXT(...)15...; PXT(...)20...; PXT(...)25...; PXT(...)32...; PXT(...)38...;
PXT(...)40...; PXT(...)51...; PXT(...)60...; PXT(...)65...; PXT(...)80...; PXT(...)80L...;
PXT(...)100...; PXT(...)125...;**

Manufactured by Tapflo Sp. z o.o., Poland for:

Tapflo Group AB

Filaregatan 4

442 34 Kungälv, Sweden

This declaration of conformity is issued under the sole responsibility of the manufacturer.

Object of declaration: **HIGH PRESSURE HOSE PUMPS WITH GEARMOTOR DESIGNED FOR USE IN POTENTIALLY EXPLOSIVE ATMOSPHERES**



The object of the declaration described above is in conformity with the relevant Union harmonisation legislation:

- Directive **2006/42/EC** of European Parliament and of the Council of 17 May 2006 on machinery;
- Directive **2014/34/EU** of the European parliament and of the council of 26 February 2014 on Equipment or Protective System intended for use in potentially explosive atmospheres

Applied harmonised standards:

- **EN ISO 80079-36:2016-07**
- **EN ISO 80079-37:2016-07**

ATEX marking:

  **II 2G IIB T4 Gb X**
-10° ≤ Ta ≤ +40°C

Signed for and on behalf of Tapflo Group AB



Per Antonsson

Chief Executive Officer

Kungälv, 09.08.2023

0. GENERAL

0. GENERAL

0.1. Introduction

The Tapflo Hose Pump range is a series of pumps for industrial and hygienic applications. The pumps are designed to be safe, simple and easy to use and maintain. The pumps are suitable for almost all different liquids used by the industry today.

The pumps are powered with an electric motor which is coupled with the rotor. To decrease the motor rotational speed a gearbox is used.

With proper attention to maintenance, Tapflo Pumps will give efficient and trouble free operation. This instruction manual will familiarise operators with detailed information about installing, operating and maintaining of the pump.

When installing, operating and maintaining of the pump unit you must strictly follow the IOM manual. Otherwise injury or life hazard may occur.

In case any instructions in this manual are unclear or any information is missing, contact Tapflo before handling the pump.

0.2. Warning symbols

The following warning symbols are present in this instruction manual. This is what they say:



This symbol stands next to all safety instructions in this instruction manual where danger to life and limb may occur. Observe these instructions and proceed with utmost caution in these situations. Inform also other users of all safety instructions. In addition to the instructions in this instruction manual, the general safety and accident prevention regulations must be observed.



This signal stands at points in this instruction manual of particular importance for compliance with regulations and directives, for correct work flow and for the prevention of damage to and destruction of the complete pump or its subassemblies.



This symbol signals possible danger caused by the presence of electric fields or live wires.

0.3. Qualification and training of personnel



The personnel in charge of installation, operation and maintenance of the pumps we produce must be qualified to carry out the operations described in this manual. Tapflo shall not be held responsible for the training level of personnel and for the fact that they are not fully aware of the contents of this manual. In case any instructions in this manual are unclear or any information is lacking, contact Tapflo before handling the pump.

1. INSTALLATION

1. INSTALLATION

1.1. Operation principle

The Tapflo hose pump is driven by a gear-motor. The rotor is installed directly on the shaft. It is equipped with shoes or has a special shape itself. The shoes compress the hose creating vacuum on the suction side of the pump and pressure on the discharge to transfer the liquid. The rotary movement of the shoes compresses the hose along the casing wall, constantly sucking/pushing the liquid through the hose. Flow is reversible as pumping direction depends on motor rotation. Pump casing is filled with lubricant to reduce the friction between the hose and the shoes. The hose and the pump inserts (connections) are the only parts of the pump that are in contact with the pumped liquid.

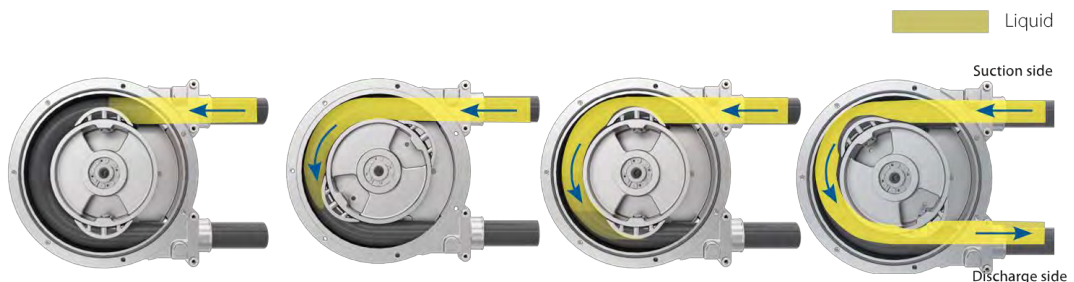

1.2. Receiving inspection

Although precaution is taken by us when packing and shipping, we urge you to carefully check the shipment on receipt. Make sure that all parts and accessories listed on the packing list are accounted for. Immediately report any damage or shortage to the transport company and to us.

1.3. Lifting and transportation



Before handling the pump check the weight of the pump (see 6. "Data"). Refer to Your local standards on how to handle the pump. If the weight is excessive to transport by hand it must be lifted using slings and a suitable lifting device e.g. a crane or forklift.

The pump is equipped with eye bolts to ease transportation.

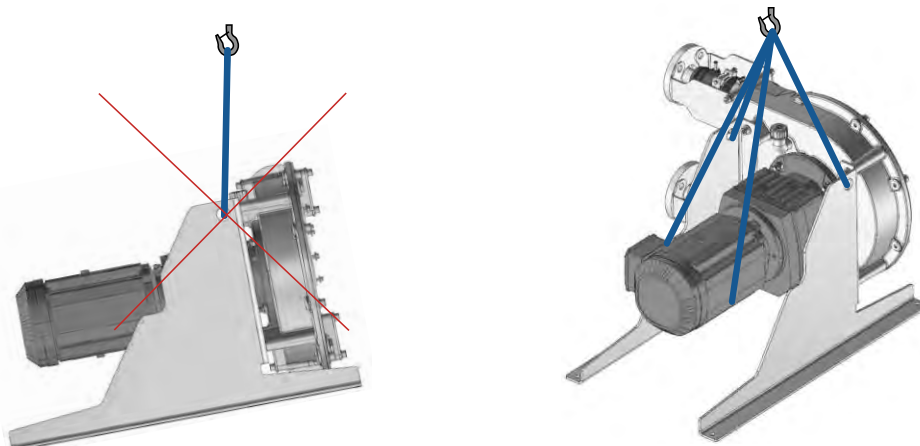

Never lift the pump under pressure.

Be careful that nobody passes under the pump when lifted.

Never try to lift the pump by the manifolds or hoses attached to the pump.

1. INSTALLATION

1.4. Storage



If the equipment is to be stored prior to installation, place it in a clean location. The pump should be stored in an ambient temperature of 15°C (59°F) to 25°C (77°F) and relative humidity below 65%. It should not be exposed to any heat source e.g. radiator, sun as this could result in a negative way on the tightness of the pump. Do not remove the protective covers from the pump.

When in storage, turn the shaft by hand at least twice per month. The pump-motor unit should always be stored indoor in dry, vibration and dust free conditions. If the pump is to be stored more than 1 month, remove the hose form the pump. If this is not possible, run the pump 10 min per week. For pump sizes PT5 – PT20 position the rotor so that one of the lobes is submerged in the lubricant.

Spare hoses must be stored in the same conditions as the pump. What is more, they should be protected from direct sunlight. Rubber materials are subject to aging and their performance and lifetime decrease with time.

NOTE! Do not remove protective covers from the hose when in storage.

1.5. Foundation



The pump-motor unit must stand on and be fixed to a sufficiently rigid structure that can support the entire perimeter on which the unit stands. The foundation on a firm bottom is the most satisfactory. Once the pump is in position, adjust level with metal shims between the feet and the surface on which it stands. Check that the feet of the pump motor unit stand well on each of them. The surface on which the foundation stands must be flat and horizontal. If the unit is fitted on a steel structure, make sure that it is supported so that the feet do not warp. In any case, it is advisable to fit some anti-vibration rubber pieces between the pump and the brickwork.

1.6. Environment



- There should be enough space in the vicinity of the pump in order to operate, maintain and repair it.
- The area in which the pump is operated, must be sufficiently ventilated. Excessive temperature, humidity or dirt may affect the pump operation.
- Behind the cooling fan of the motor there must be sufficient room for the hot air to escape the motor.

1.7. Suction and discharge piping

A pump is generally part of a piping system that can include a number of components such as valves, fittings, filters, expansion joints, instruments, etc. The way the piping is arranged and the positioning of the components has a great influence on the operation and the lifetime of the pump. The pump cannot be used as a support for the components connected to it.

The flow of liquid from the pump must be as even as possible. It is advisable to avoid any tight bends or drastic reductions of diameters that may cause flow resistance in the installation. In case of diameter reduction, it is advisable to use appropriate conical reductions (possibly eccentric on suction side and concentric on discharge side) at changes of diameter and at a minimum distance from pump connections of five diameters.

1. INSTALLATION

1.7.1. Connection of suction pipe

Remember that the suction pipe/connection is the most critical point, especially if the pump is priming. Just a small leakage will dramatically reduce the suction capability of the pump. When connecting the suction pipe, the following is recommended:

- 1) For satisfactory operation, use a reinforced hose (the suction power may otherwise shrink the hose) or other flexible piping. The internal diameter of the hose should be at least same as on the suction connection (at the bottom of the pump) to have best suction capability. If the diameter of a hose is smaller, it will affect the pump's performance or cause its malfunction.
- 2) Make sure that the connection between the hose and the pump is completely tight, otherwise the suction capability will be reduced.
- 3) Always use as short suction pipe as possible. Avoid air pockets which can emerge within long piping.

1.7.2. Connection of discharge pipe



For this connection it is only recommended to have a simple and positive flow connection. Use a hose or flexible piping (minimum one meter) between the discharge connection and any rigid fixed piping. Coil the hose at least one turn. All components (hose, pipe, valves etc.) on the discharge piping must be designed for appropriate PN, according to pump maximum pressure. It is recommended to install a check-valve on the discharge side in order to protect the pump from water hammer effect that can be created in the discharge pipeline. If overpressure in the discharge line is possible, an appropriate pressure safety device should be installed to protect the pump. A device must be incorporated into the pump, system, or drive, to prevent the pump exceeding the rated pressure. Do not allow the pump to operate with a closed/blocked discharge unless a pressure relief device is installed.

A pressure relief valve must be assembled obligatory on the discharge side by the customer if overpressure in the system is possible.

1.8. Health and safety

The pump must be installed according to local and national safety rules.



The pumps are designed for particular applications. Do not use the pump on applications different from that for which it was sold without consulting us to ascertain its suitability. The pumps are tested with water. If the pumped product can come into reaction with water, make sure the pump is dry before putting it into operation.

1.8.1. Protection



In the interest of health and safety it is essential to wear protective clothing and safety goggles when operating, and/or working in the vicinity of Tapflo pumps.

1.8.2. Electrical safety



Do not carry out any maintenance or/and operation on the pump while it is running or before it has been disconnected from the power supply. Avoid any danger caused by electric power (for details see current regulations in force). Check that electrical specifications on the data plate are equivalent to the power supply to which it will be connected.

1. INSTALLATION

1.8.3. Potentially explosive atmospheres – ATEX



The standard PT series pumps are not allowed to operate in potentially explosive atmospheres. Special PXT pumps are available for such applications. Follow ATEX supplementary instructions (see section 7) and local/national rules for safe use.

1.8.4. Chemical hazard



Whenever the pump is to be used for pumping a different liquid, it is essential to clean the pump beforehand in order to avoid any possible reaction between the two products.

1.8.5. Noise level



Hose pumps, including the motor, in normal operating conditions produce a sound level below 70 dB(A). The major sources of noise are: liquid turbulence in the installation, cavitation or any other abnormal operation that is independent from the pump construction nor the pump manufacturer. The user must provide suitable protective means if the sources of noise could produce a harmful noise level for operators and for the environment (in compliance with current local regulations).

1.8.6. Temperature hazards



➤ Raised temperature can cause damage on the pump and/or piping and may also be hazardous for personnel in the vicinity of the pump/piping. Avoid quick temperature changes and do not exceed the maximum temperature specified when the pump was ordered. See also general max temperatures based on water in chapter 6. "Data".



➤ When the pump is exposed to ambient temperature variations or if there is big difference between the temperature of the product and the surrounding, the tightening torques of the casing nuts should be checked periodically as part of preventive maintenance. Contact Tapflo for interval proposals.



➤ Ambient temperature limits range from -20°C to +40°C. To operate under negative ambient temperatures, it is necessary to replace 30% of the lubricant with glycerine-based antifreeze, e.g. G13 antifreeze (see section 3.7 "Casing emptying and lubricant filling procedure"). However, in food grade, cosmetic, and pharmaceutical applications, antifreeze must not be used since it may contaminate the pumped product during hose rupture, contact Tapflo for more information.

➤ If a hot product is pumped, the pump should not stand still when filled for a longer period of time. This could cause leakage from the pump.

➤ Below 0°C (32°F) plastic materials become more fragile what can cause accelerated wear of parts made of these materials. This is a hazard that has to be accepted when pumping such cold products. Also in such case, when a pump is not operational it should be drained of all liquid.

➤ Bear in mind that the viscosity of the product changes with temperature. This has to be taken into consideration when selecting the pump.

➤ The fluid remaining in the connected piping, as well as in the pump itself, may expand because of freezing or heat, which may cause damage to the pump or/and piping, and lead to leakage of the fluid.

➤ Some parts of the hose pump can become hot during operation and cause burns, therefore make sure to use appropriate protection when handling the pump.

1. INSTALLATION

1.8.7. Rotating parts



Do not tamper with the guard of the rotating parts, do not touch or approach rotating parts in movement.

1.8.8. Cleaning and disinfection



Cleaning and disinfection of the pump system is of greatest importance when the pump is used in a food process installation. Use of a pump system that is NOT cleaned or disinfected can cause contamination of the product

1.9. Installation recommendations

- If liquid contains solid particles bigger than max allowable size for the corresponding pump size, a strainer on the suction side should be used.
- Manometers or pressure sensors must always be installed on the suction and discharge side of the pump to determine proper operation of the pump.
- The suction and discharge piping must be fastened properly so that no strain occurs on the pump manifolds.
- It is recommended to install a check-valve on the discharge side in order to protect the pump from water hammer effect that can be created in the discharge pipeline.
- The suction line should be as short and straight as possible.
- A gate valve could be installed on the discharge line for easier pump disconnection from the pipeline (**ATTENTION!** The gate valve should never be closed during pump operation).
- A pressure relief valve must be assembled obligatory on the discharge side by the customer if overpressure in the system is possible. A device must be incorporated into the pump, system, or drive, to prevent the pump exceeding the rated pressure.

1.9.1. Minimum required distance for hose removal

During pump installation provide enough space to be able to perform hose replacement procedure. Follow the guideline below:

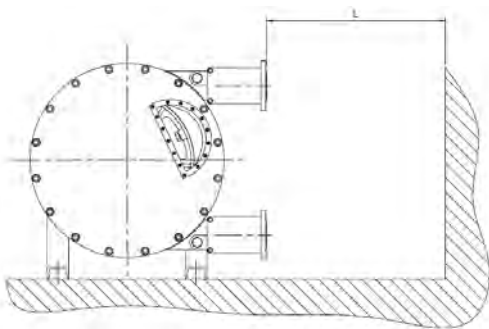

PUMP	L [mm]	PUMP	L[mm]
PT5	400	PT51	1400
PT10	400	PT60	1400
PT15	500	PT65	1500
PT20	500	PT80	1600
PT25	800	PT80L	2000
PT32	1000	PT100	2800
PT38	1000	PT125	3000
PT40	1200		



NOTE!

Even if all above safety instructions are met and complied with, there still exists a minor danger in the event of a leakage or mechanical damage of the pump. In such case the pumped product can emerge on sealing areas and connections.

1. INSTALLATION

1.10. Instruments



In order to ensure a proper control of the performance and the conditions of the installed pump, we recommend using the following instruments:

- a pressure-vacuum gauge on the suction piping;
- a pressure gauge on the discharge piping.

The pressure intakes must be made of straight pieces of piping at a distance of minimum five diameters from the pump inlets. The pressure gauge on discharge must always be fitted between the pump and the regulation valve. The output can be read on the pressure gauge, transformed into meters and then compared with the typical curves.

1.10.1. Electric power

The electric power absorbed by the motor can be measured by means of a wattmeter or an amp gauge.

1.10.2. Optional instruments

The optional instruments can indicate if pump is working in an abnormal way. The abnormal conditions can be caused by: accidentally closed valves, lack of pumped liquid, overloads, etc.

1.10.3. Thermometer

If the temperature of the pumped liquid is a critical parameter, provide the installation with a thermometer (preferably on the suction side).

1.10.4. Pressure safety device



The pump cannot run against higher pressure than stated in this IOM manual. Therefore the pump must be equipped with an appropriate pressure safety device such as a pressure switch, bypass line with a pressure relief valve or motor overload protection that will automatically stop the pump when pressure rises above allowable levels.

1. INSTALLATION

1.11. Motor connection



An expert electrician must always carry out the electrical connection. Compare the power supply with the data plate specifications and then choose a suitable connection. The type of connection is stated on the motor data plate and can be Y (star) or D (Delta), according to the power supply of the motor (see figure below).

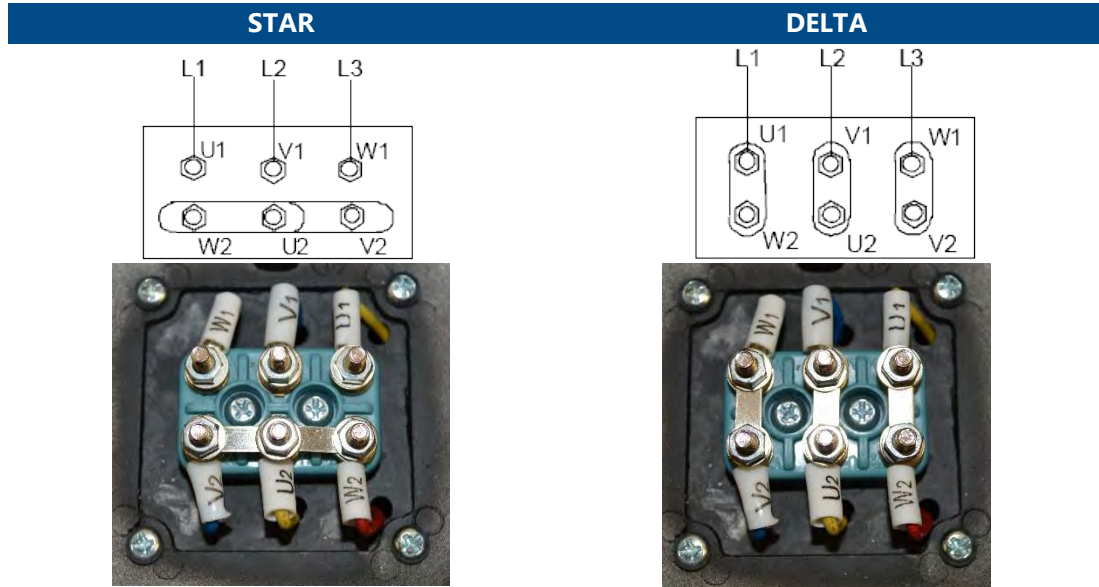

Follow the connection standard used in the plant. In no case connect the electrical motor directly to supply network but use a suitable electric switchboard equipped with a knife switch and suitable safety devices (e.g. motor breaker switches) in the power circuit. Safety devices against overloads must also protect the motors. Make sure that the motor has suitable grounding and that it has been connected properly.

1.12. Gear-motor standard

As a standard Tapflo Hose pump are equipped with gear-motors of the following parameters:

- International Mounting Arrangement – **B5**
- Number of poles / Rotation speed [rpm] – **4 / ~1400**
- **Non ATEX**
- Protection grade – **IP55**
- Voltage – **3 phase; 230/400 (below 3 kW) or 400/690V (above 3 kW); 50 Hz**
- Efficiency class – **IE3**
- Output rpm – **12 ÷ 63 @ 50 Hz**
- Thermal protection – **PTC**

The rated gear-motor rpm should not be exceeded. If you want to operate the pump at higher speed, consult Tapflo for guidelines.

2. OPERATION

2. OPERATION

2.1. Before starting the pump



- Make sure the pump is installed according to the installation instructions (chapter 1).
- Filling of the pump with liquid before start is not necessary.
- Ensure that correct amount of lubricant is present inside the pump casing. For information on lubricant and the filling procedure, refer to chapter 3.7 "*Casing emptying and lubricant filling procedure*".
- Make sure to plug all pump openings to prevent lubricant leakage or/and liquid leakage in the event of a hose rupture. This applies to various openings, including the drainage channels, as well as sensor mounting openings.
- Check manually that the motor is free to turn, moving the motor cooling fan.
- Make sure that the piping is not clogged and is free from residues or foreign objects.
- The suction shut-off valve (if any) must be completely open.
- The shut-off valve on the discharge side (if any) must be completely opened.
- Any auxiliary connections must all be connected.
- Ensure proper shoe shimming, see section 3.11 "*Shoe shimming*" for information about the shim adjustment procedure, and 6.3 "*Shimming tables*" for amount of shims for specific operating conditions.
- When installation is new or reinstalled, a test run of the pump with water should be conducted to make sure that the pump operates normally and does not leak.
- When installation is new or reinstalled, check the pump casing nuts tightening torque (see chapter 6.5 "*Tightening torques*").
- After approximately one week of operation, the torque should be checked again. This is important to prevent possible leakage.
- Starting the electrical motor makes the pump run at full capacity!

2.2. Starting and operation



Open the discharge valve and start the electric motor. The pump must not run with completely closed discharge - these conditions can seriously damage the pump and cause injury to the operator.



If the pressure shown on the pressure gauge on the discharge piping does not increase, turn off the pump immediately and release pressure carefully. Repeat the connection procedure.



Make sure that pressure on the discharge does not exceed the rated pressure!

A device must be incorporated into the pump, system, or drive, to prevent the pump exceeding the above rated pressure. Do not allow the pump to operate with a closed/blocked discharge unless a pressure relief device is installed.

A pressure relief valve must be assembled obligatory on the discharge side by the customer.

Pump can be equipped with such a safety device on customer's request.

If there are changes of flow rate, head, density, temperature or viscosity of the liquid, stop the pump and get in touch with our technical service.

2. OPERATION

The performance of the pump can be adjusted by means of a frequency inverter. The flow depends on direction of rotation and can achieve full capacity in both directions of rotation.

2.2.1. Dry running

Although the pump is prepared for dry running it is important to have in mind that long periods of dry run may cause damage to the wearing parts of the pump. What is more, an empty pump should operate at low speeds – controlled by a frequency inverter.

2.2.2. Dead head



The pump cannot operate with closed discharge valve. This may lead to pump malfunction and cause injury to operators in the vicinity of the pump.

The discharge pressure can never exceed pump rated pressure.

2.2.3. Optimization of the pump lifetime

- Continuous operation at higher frequency than 50 Hz will cause premature wear of the components. As a general rule, we recommend to run the pump at $\pm 20\%$ of the rated frequency.
- When reducing the motor rotation speed, it is important to monitor the surface temperature of the gear-motor and ensure that it does not exceed the nominal working temperatures specified by the gear-motor manufacturer.

2.3. Pump stopping



Turn off the motor to stop the pump. Close the discharge shut-off / regulation valve immediately after. The reverse sequence is not recommendable, especially with larger pumps or longer delivery piping. That is to avoid any problems due to water hammering. It is therefore advised to install a check valve on the discharge to protect the pump. If a suction shutoff valve has been installed, it is advisable to close it completely after pump is fully stopped.

The pump should be stopped by cutting of electrical power to the motor or frequency inverter (if used – at 50 Hz cool down should be set to 5 seconds).



NOTE! Never stop the pump by completely closing the discharge valve without motor shut down.

2.4. Cleaning and disinfection



Cleaning and disinfection of the pump system is of greatest importance when the pump is used in a food processing installation. Use of a pump system that is NOT cleaned or disinfected can cause contamination of the product. The cleaning cycles as well as chemicals to use for the cleaning vary depending on the pumped product and the process. The user is responsible to establish a suitable cleaning and / or disinfection program according to local and public health and safety regulations.



If the outside of the pump is to be rinsed or flushed, the power supply must be disconnected beforehand.

2. OPERATION

2.5. Residual risks



Even with proper application and observance of all points listed in this operating manual, there is still an estimable and unexpected residual risk when using the pumps. It may leak, fail due to wear, application-related causes or system-related circumstances.

2.6. Disposal after expiration of the expected lifetime

Pump components can be recycled, it must be disposed of properly, according to local regulations. It should be noted that potentially dangerous fluid residues may remain in the pump and can create a hazard to the operator or the environment, therefore the pump has to thoroughly cleaned before disposal.

2.7. Waste of electrical and electronic equipment (WEEE) directive



Users of electrical and electronic equipment (EEE) with the WEEE marking per Annex IV of the WEEE Directive must not dispose of end of life EEE as unsorted municipal waste, but use the collection framework available to them for the return, recycle, recovery of WEEE and minimize any potential effects of EEE on the environment and human health due to the presence of hazardous substances. The WEEE



marking applies only to countries within the European Union (EU) and Norway. Appliances are labelled in accordance with European Directive 2002/96/EC. Contact your local waste recovery agency for a designated collection facility in your area.

2.8. Actions in emergency



In case of a leakage of an unknown fluid, respiratory protection should be worn and contact with the fluid avoided. During firefighting, no special hazards are to be expected from the pump itself. In addition, the currently handled fluid and the corresponding safety data sheet must be taken into account. When fluid leakage occurs, the power supply has to be closed and the pressure released. During spillage of an aggressive liquid, local and national safety rules must be followed.

3. MAINTENANCE

3. MAINTENANCE



Maintenance work on electrical installations must be performed by qualified personnel and only when the power supply has been shut off. Wait five minutes for capacitor to discharge before opening the pump. Follow the local and national safety regulations.

Due to size of some of the pumps at least two persons should perform maintenance activities and if needed use appropriate lifting devices according to local rules and regulations.

3.1. Inspections

- Periodically check suction and discharge pressures.
- Inspect the gear-motor according to the instructions from the motor manufacturer.
- Gear oil must be exchanged in accordance with the gear manufacturer instruction manual.

3.2. When the pump is new or reassembled



If the pump is new or reassembled after maintenance it is important to retighten the screwed connections after one week of operation.

Make sure to use the right torque – see chapter 6.5. *“Tightening torques”*.

3.2.1. Performance test

When installation is new, a test run of the pump should be conducted. Gauge the capacity at specific pump speed. This information is useful for checking performance in the future as wear takes place. You will be able to set schedules for maintenance of the pump and to select spare parts to be kept on stock.

3.3. Routine inspection



Frequent observation of the pump operation is recommended to detect problems. A change in sound of the running pump can be an indication of wearing parts (see chapter 3.5 *“Location of faults”* below). Hose damage can be the main reason of liquid leakage therefore it is advisable to install a hose rupture monitoring system that can detect the hose damage and stop the pump when liquid enters the pump chamber.

Leaking liquid from the pump and changes of performance may also be detected. Routine inspections should be conducted frequently. We recommend to conduct a daily check and keep records of the following:

- Leakage of fluid from any connection of the pump
- Tightness of all connection parts of the pump and any peripheral equipment
- Complete inspection in regular intervals has been done

In case any of the above is not fulfilled, do not start the pump and implement corrective actions.

Establish a preventive maintenance schedule based on the pump’s service history. Scheduled maintenance is especially important to prevent spills or leakage due to hose failure.

3. MAINTENANCE

3.4. Complete inspection



The intervals for a complete inspection depend upon the operation conditions of the pump. The characteristics of the liquid, temperature, materials used in the pump and running time decide how often a complete inspection is necessary. Nevertheless, Tapflo recommends to inspect the pump at least once a year.

If a problem has occurred, or if the pump is in need of a complete inspection, refer to chapters 3.5 "Location of faults" and 3.6 "Disassembly of the pump". You are of course warmly welcome to consult Tapflo for further help.

Parts that are subject to wear should be kept in stock, see our recommendations in chapter 5.20 "Stocking recommendation".

3.5. Location of faults

PROBLEM	POSSIBLE ISSUE	POSSIBLE SOLUTION
Pump does not run	Lack of power supply The rotor is stalling Lubricant level detector switched off the pump	Check if the motor is connected properly Check if power supply is ON Check the fixing of the hose Check if the discharge pressure is not too high Check if particles are not blocking the hose Check for any lubricant leakage Check proper functionality of the lubricant detector
The suction is bad	Suction connection is not tight Suction connection is blocked Hose is blocked or damaged Air in suction / discharge line	Tighten the suction line Clean suction line Check for any debris inside the hose Vent suction / discharge line
The pump runs irregular	Hose is blocked or damaged	Check for any debris inside the hose
Bad flow/pressure	Not enough shims under shoes Suction blocked Pressure losses on suction side Too viscous liquid Air in liquid Hose is blocked or damaged	Check shimming and adjust if necessary Check / clean suction connection Check/change installation on suction side Check if pump speed is proper for viscosity Seal suction line; check / refill container Check for any debris inside the hose, replace hose if necessary
Liquid leaks from the pump	Screws on the pump not properly tightened Cover seal worn Shaft seal or seal ring worn Tension / stress from the installation	Check tightening torques of the screws Replace cover seal if necessary Replace if necessary Adjust installation, eliminate stress, when using a dampener provide separate support for it.
Hose life is too short	Wrong selection of material Long periods of dry running Too high discharge pressure Too high speed Wrong shimming Too high liquid temperature	Contact us for information on material selection When dry, run pump slowly (see chapter 2.2) Check if pump rated pressure is not exceeded Check if the discharge line is not blocked Reduce the pump speed Check shimming and adjust if necessary Contact us for information on material selection
Overheating of motor	Flow rate too high Liquid parameters different than calculated	Reduce the flow / rotation speed of the motor Check pumped liquid parameters
Overheating of the pump	Flow rate too high Liquid temperature too high Foreign objects in the liquid Pump is not filled with liquid	Reduce the flow / rotation speed of the motor Cool the liquid Use a filter on the suction side Fill pump with liquid

3. MAINTENANCE

<p>Noise and vibration</p>	<p>The pump sucks air Suction pipe is blocked Flow rate too high Loads on the pipes Foreign objects in the liquid Liquid parameters different than calculated</p>	<p>Make sure all connections are tight Check pipes / valves and filters on suction line Reduce the flow / rotation speed of the motor Connect the pipes independent of the pump Use a filter on the suction side Checked pumped liquid parameters</p>
<p>Abnormal wear</p>	<p>The pump sucks air Liquid temperature too high Loads on the pipes Foreign objects in the liquid</p>	<p>Make sure all connections are tight Cool the liquid Connect the pipes independent of the pump Use a filter on the suction side</p>

3.6. Disassembly of the pump

The numbers put in brackets, refer to the part numbers in the spare part drawings and spare part lists in chapter 5. "Spare parts".



The disassembly should be performed only by qualified personnel. There should always be at least two persons present during disassembly.



Each operation to be fulfilled with the machine must always be carried out once all the electrical contacts have been disconnected. The pump-motor unit must be placed in a position where it cannot be started unintentionally.



Before servicing in any way the parts that come in contact with the pumped liquid, make sure that the pump has been fully emptied and washed. When draining the liquid, make sure that there is no danger for people or the environment.

3.6.1. Before the disassembly procedure



Be sure to drain all liquid from the pump. Cleanse or neutralize the pump thoroughly. Disconnect the electrical connection and then the suction and discharge connections.

3.6.2. Disassembly procedure

The following procedure shows a complete pump disassembly. However, keep in mind that there is no need to completely disassemble the pump for standard pump maintenance. Refer to the further sections for specific maintenance actions.

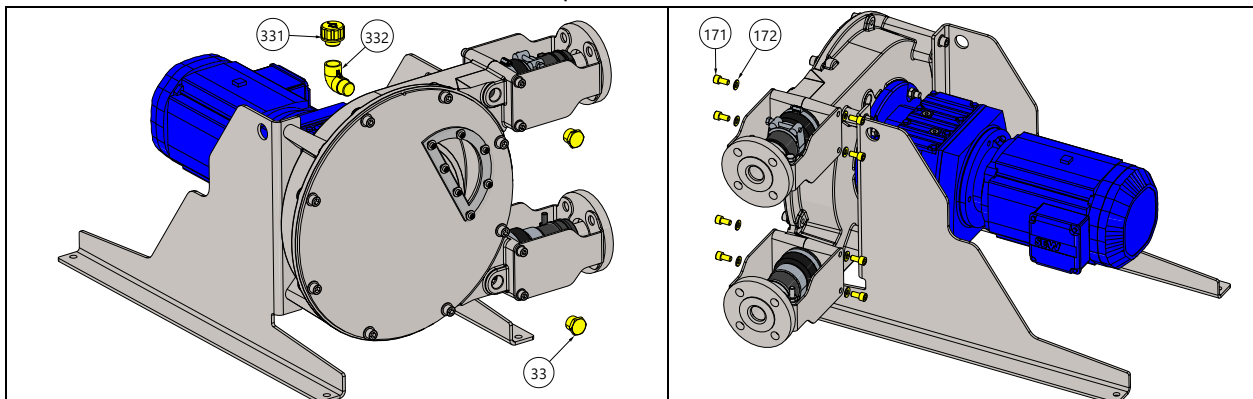

Fig. 3.6.1

Unscrew the breather cap [331], breather cap elbow [332] and the drain plugs [33].

NOTE! The pump is filled with lubricant. In order to drain the pump follow the "Casing emptying and lubricant filling" procedure in chapter 3.7.

Fig. 3.6.2

Unscrew the bracket mounting bolts [171] and remove them with their washers [172].

3. MAINTENANCE

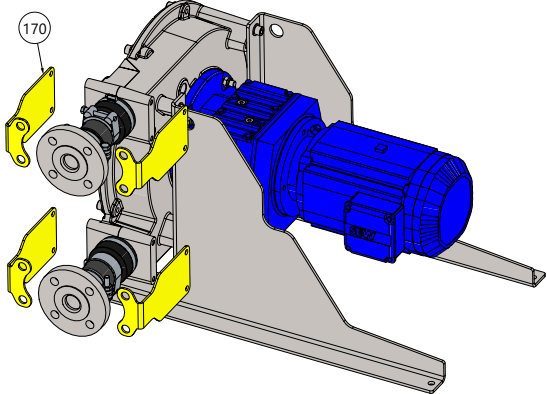
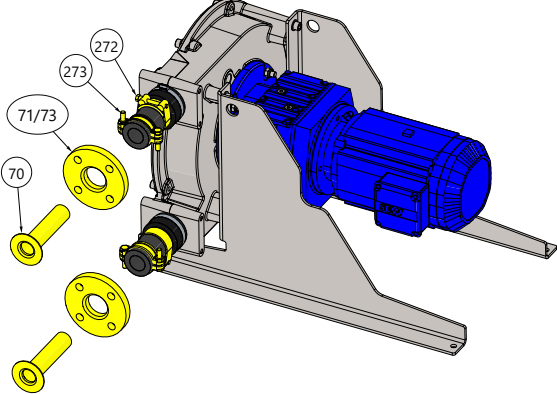
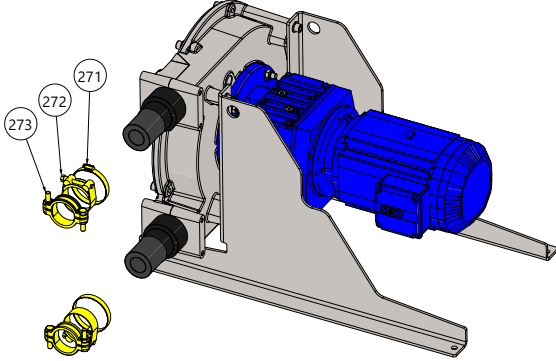
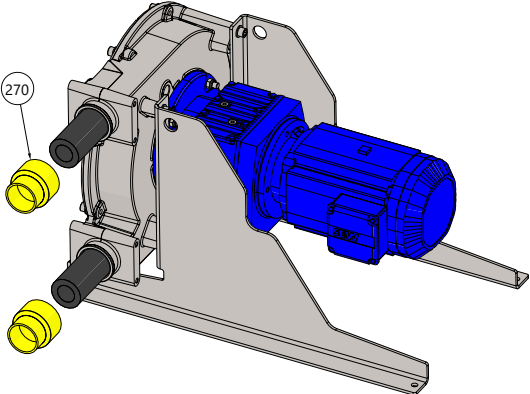
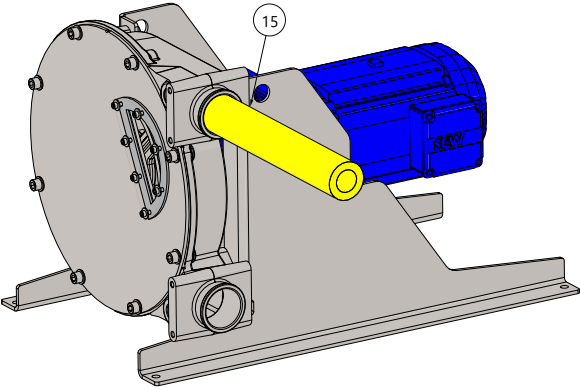
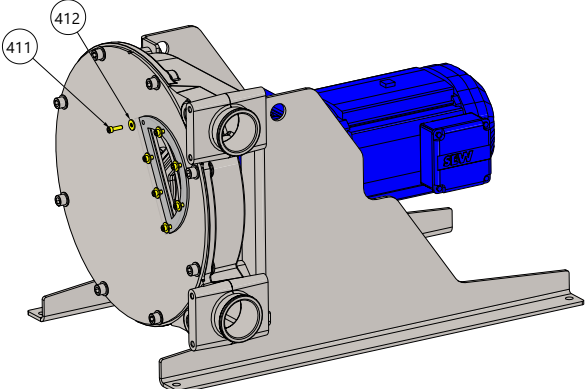
	
<p>Fig. 3.6.3 Remove the brackets [170] from the pump.</p>	<p>Fig. 3.6.4 Loosen the hose clamps [272] and [273] and remove the flange pipe / insert [70] with the flange rings [71/73].</p>
	
<p>Fig. 3.6.5 Loosen the big clamp band [271] and remove all clamp bands from the pump.</p>	<p>Fig. 3.6.6 Remove the boot covers [270].</p>
	
<p>Fig. 3.6.7 Remove the hose [15] from the pump. NOTE! In order to remove the hose, follow the <i>Hose replacement</i> procedure in chapter 3.9.</p>	<p>Fig. 3.6.8 Unscrew the revision window mounting bolts [411] and remove them with their washers [412].</p>

3. MAINTENANCE

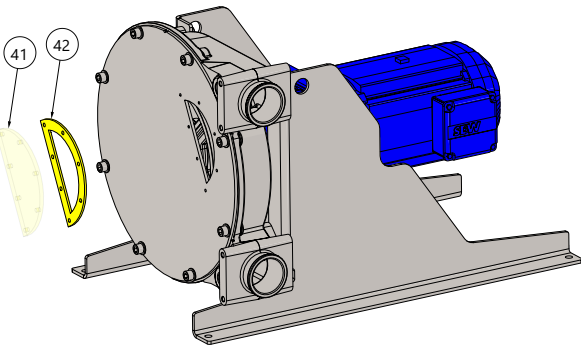
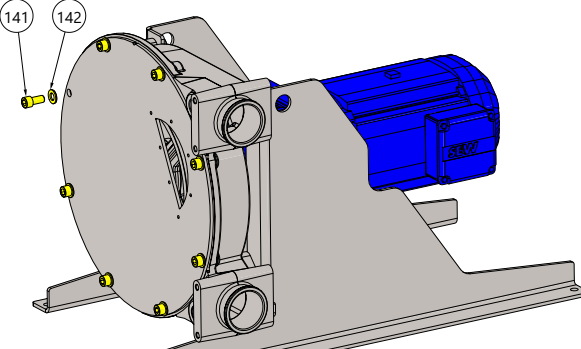
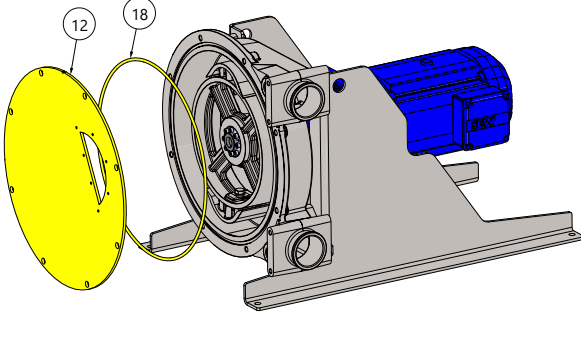
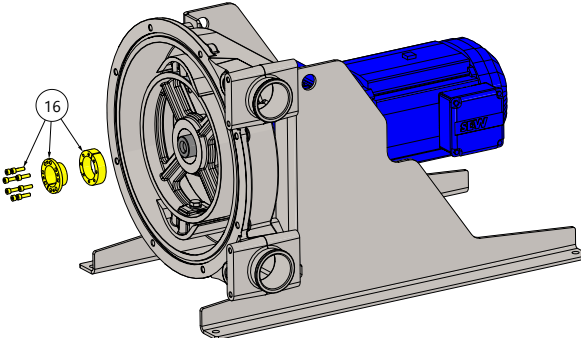
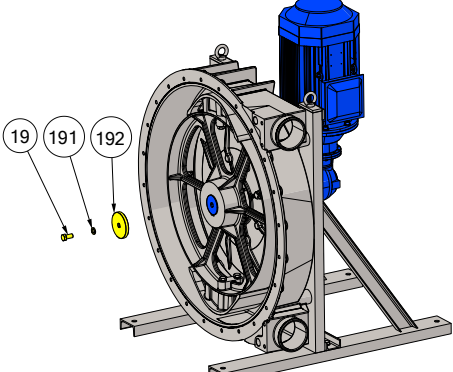
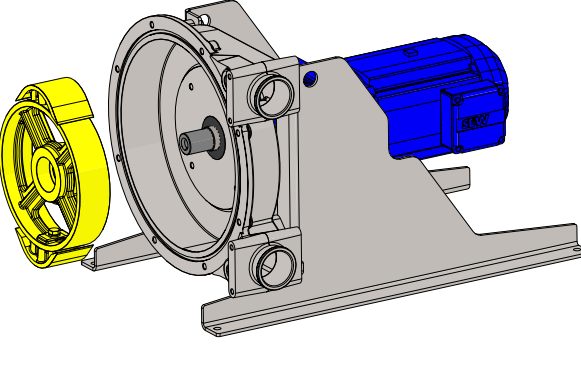
	
<p>Fig. 3.6.9 Remove the revision window [41] with its gasket [42].</p>	<p>Fig. 3.6.10 Unscrew the front cover mounting bolts [141] and remove them with their washers [142]. NOTE! In big pump sizes, the front cover is very heavy and requires special removing procedure. Refer to chapter 3.10. "Pump casing cleaning procedure" for more information.</p>
	
<p>Fig. 3.6.11 Remove the front cover [12] with its seal [18]. NOTE! In big pump sizes, the front cover is very heavy and requires special removing procedure. Refer to chapter 3.10. "Pump casing cleaning procedure" for more information.</p>	<p>Fig. 3.6.12A [PT5 -PT80L] Unscrew the clamping set bolts and remove the complete clamping set [16].</p>
	
<p>Fig. 3.6.12B [PT100-PT125] Unscrew the rotor mounting bolt [19] and remove rotor mounting washers [191][192].</p>	<p>Fig. 3.6.13 Remove the complete rotor assembly from the pump.</p>

3. MAINTENANCE

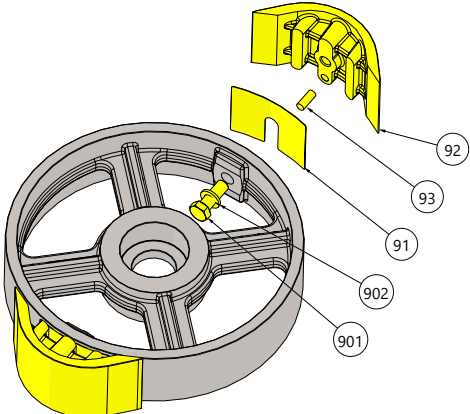
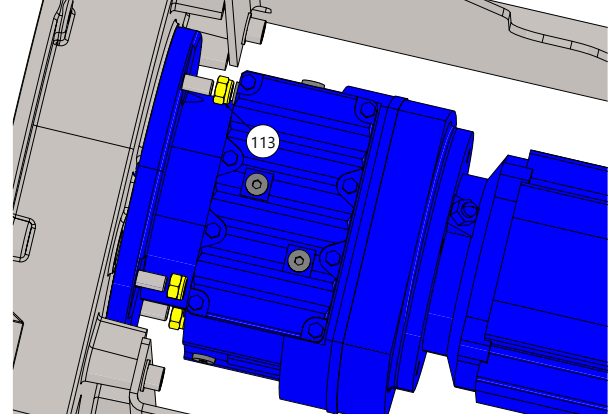
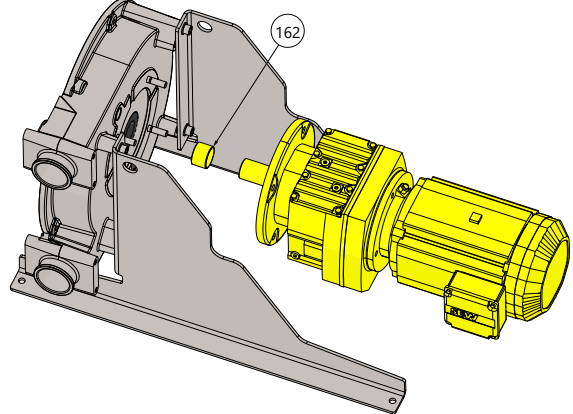
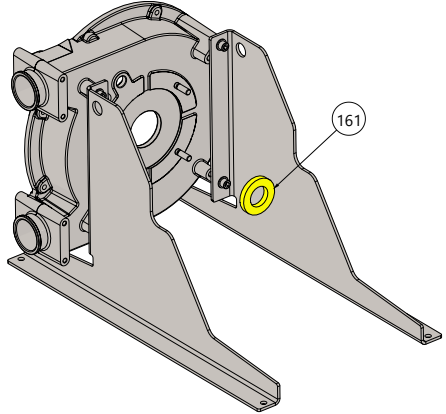
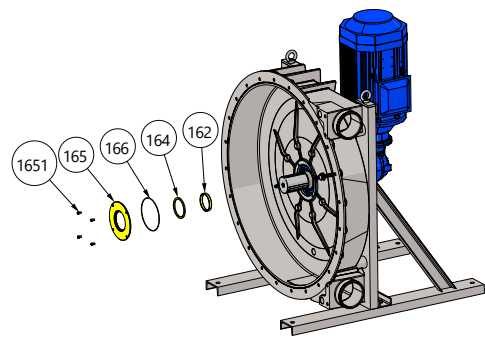
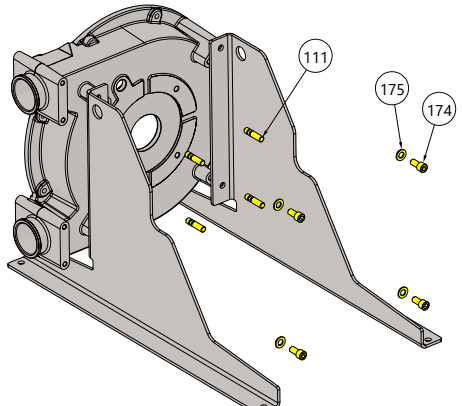
	
<p>Fig. 3.6.14 Unscrew the shoe mounting bolts [901] and remove it with its washers [902]. Remove the shoes [92] shoe centering pins [93] and shims [91].</p>	<p>Fig. 3.6.15 Unscrew the gearmotor mounting nuts [113].</p>
	
<p>Fig. 3.6.16 Remove the gearmotor along with the seal ring [162].</p>	<p>Fig. 3.6.17A Remove the shaft seal [161].</p>
	
<p>Fig. 3.6.17B – [PT125] Unscrew flange mounting bolt [1651] and remove seal flange [165] with O-ring [166]. Remove Shaft seal [162] with spacer ring [164].</p>	<p>Fig. 3.6.18 Unscrew the gearmotor mounting stud bolts [111]. Unscrew the casing mounting bolts [174] and remove them with their washers [175].</p>

3. MAINTENANCE

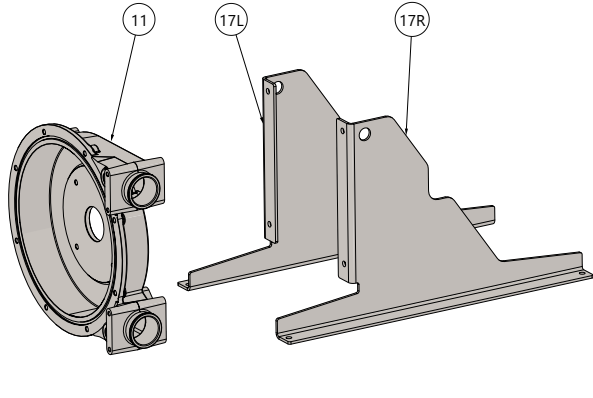
	
<p>Fig. 3.6.19 The pump is now completely disassembled. Check all components for wear or damage and replace if necessary.</p>	

3.6.3. Test run



We recommend you to conduct a test run of the pump before installing it in the system, so no liquid gets wasted if the pump leaks or perhaps does not start accordingly to wrong assembly of the pump.

After two weeks of operation retighten the nuts with appropriate torque.

3. MAINTENANCE

3.7. Casing emptying and lubricant filling procedure



For proper pump operation, it is necessary to provide a specific amount of lubricant. Failure to fulfil this requirement result in generating increased temperature and reducing the working parts' lifespan.



The quality of the lubricant inside the pump is deteriorating with time. It has to be replaced after every two hose changeovers or 5000 hours of operating time, whichever comes first. What is more, the lubricant has to be replaced every time it becomes contaminated e.g. if a hose rupture occurs.



If you experienced hose break, take health and safety precautions appropriate to the pumped liquid. Be prepared to pick up the leaked medium that fills the pump housing.

Make sure that suction and discharge valves are closed before draining.

Pump size	PT5/10	PT15/20	PT25	PT32/38	PT40	PT50/60	PT65	PT80	PT80L	PT100	PT125
Casing volume [l]	0.5	1.5	5	7	15	32	75	75	105	200	360
Lubricant Volume [l]	0.2	0.55	2	3	6	13	27	27	40	80	120

NOTE! Proceed with this procedure only after familiarizing oneself with the instructions at the beginning of section 3. "Maintenance" and all safety instruction in section 1.8. "Health and safety".

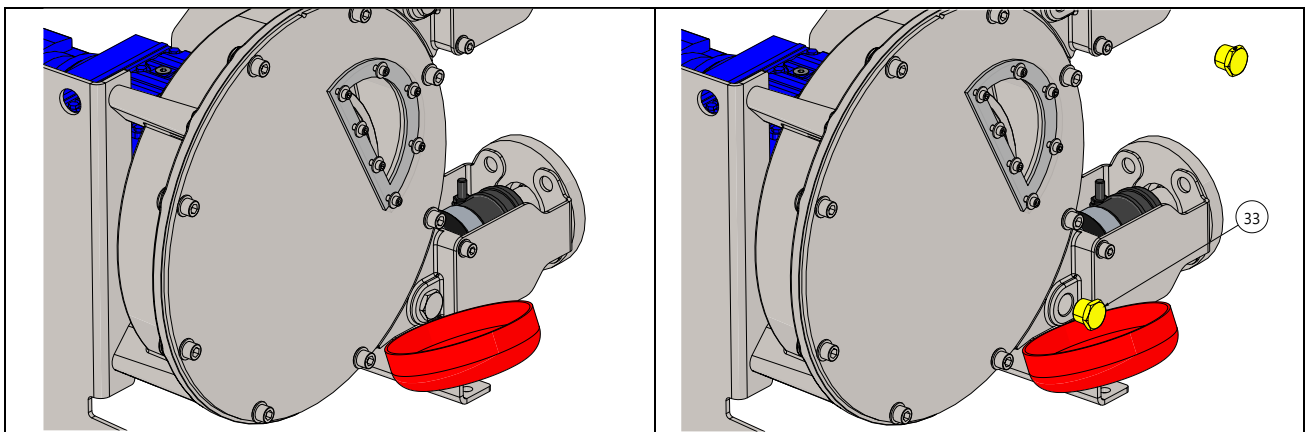

Fig. 3.7.1

Place a drip pan under the drain plug.

NOTE! Make sure the drip pan is large enough to contain the whole amount of lubricant that is inside the pump.

Fig. 3.7.2

Unscrew the plug [33] and empty the pump from the lubricant.

NOTE! If the pump is oriented with the connections facing upwards, you can initiate drainage by unscrewing a few front cover bolts [141] located at the bottom of the casing [11] and then pulling the front cover [12].

3. MAINTENANCE

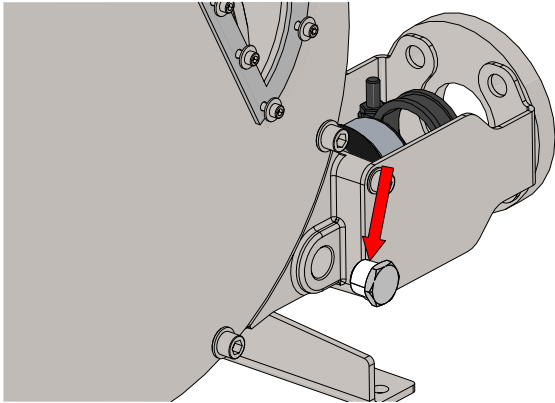
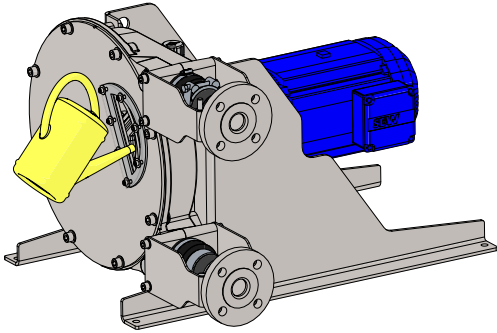
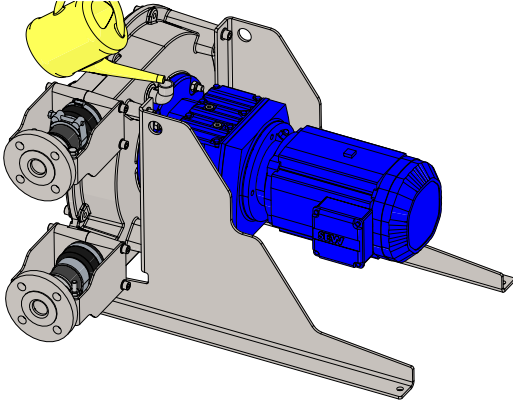
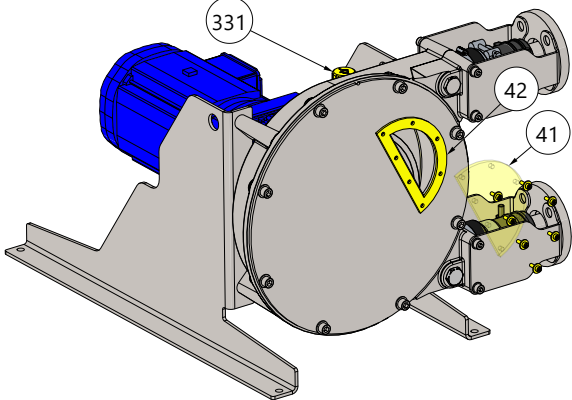
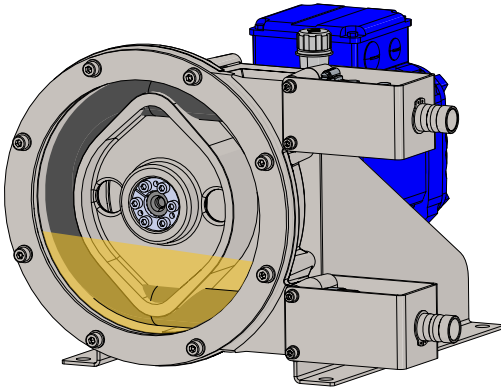
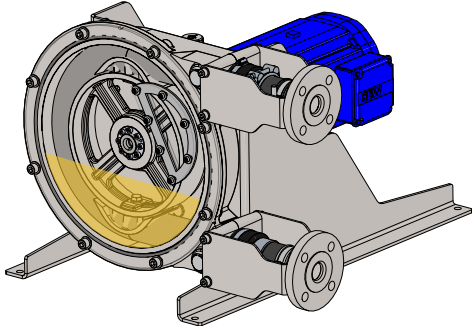
	
<p>Fig. 3.7.3 Screw the drain plug [33] back into the pump casing [11]. Use PTFE tape to seal the connection.</p>	<p>Fig. 3.7.4a In order to fill the pump with lubricant, remove the revision window [41] and its gasket [42] by unscrewing the revision window mounting screws [411] and washers [412].</p>
	
<p>Fig. 3.7.4b It is also possible to fill the pump with lubricant directly through the vent plug [331] located on the top of the pump.</p>	<p>Fig. 3.7.5 Check the condition of the revision window gasket [42] and reassemble the revision window [41] or tighten the vent plug [331].</p>
	
<p>Fig. 3.7.6a Lubricant level PT5-PT20</p>	<p>Fig. 3.7.6b Lubricant level PT25-PT125</p>
<p>Fill the pump casing [11] with appropriate amount of lubricant (see chapter 6.2. "Technical data" for specific volume. The appropriate level of the lubricant inside the pump is:</p> <ul style="list-style-type: none"> ➤ Below the shaft for PT5 – PT20; ➤ Below the bottom edge of the revision window for PT25 – PT125. 	

3. MAINTENANCE

3.8. Hose cleaning

The hose can be cleaned in place without disassembly. It can be done with water or any other appropriate agent as long as it is compatible with the hose material. Check not only the chemical compatibility but also the allowable temperature for the utilized hose.

3.9. Hose replacement

The PT pump hose is a consumable part that may break due to excessive wear, which can lead to leakage inside the pump casing. The service life of the hose is affected by various factors such as rotor speed, shoe shimming, discharge pressure, pumped liquid abrasiveness, chemical composition, and viscosity. Since it is impossible to definitively determine the lifetime of the hose, it is important to schedule preventive maintenance.

The pump can be optionally equipped with the Hose leak detector that, when coupled with appropriate automation, can immediately turn off the pump and display an alarm in case of hose rupture. It is recommended to record and store information about operating conditions and the number of working hours before the malfunction, and use it to schedule preventive maintenance. The more uniform the pump operating conditions, the more repeatable the hose life will be. See 4.4 "Hose leak detector".

In order to avoid costly downtime of the pump, it is recommended to inspect the hose after about 90% of the lifetime of the first hose as part of preventive maintenance.

The hose can be replaced without the whole pump disassembly. Before starting of this procedure, drain the pump from the lubricant according to the procedure shown in chapter 3.7. "Casing emptying and lubricant filling procedure" and clean the pump thoroughly. If you experienced hose rupture, following section 3.10. "Pump casing cleaning procedure".



NOTE! Make sure that suction and discharge valves are closed before disconnecting of the pump from installation.

NOTE! Proceed with this procedure only after familiarizing oneself with the instructions at the beginning of section 3. "Maintenance" and all safety instruction in chapter 1.8. "Health and safety".

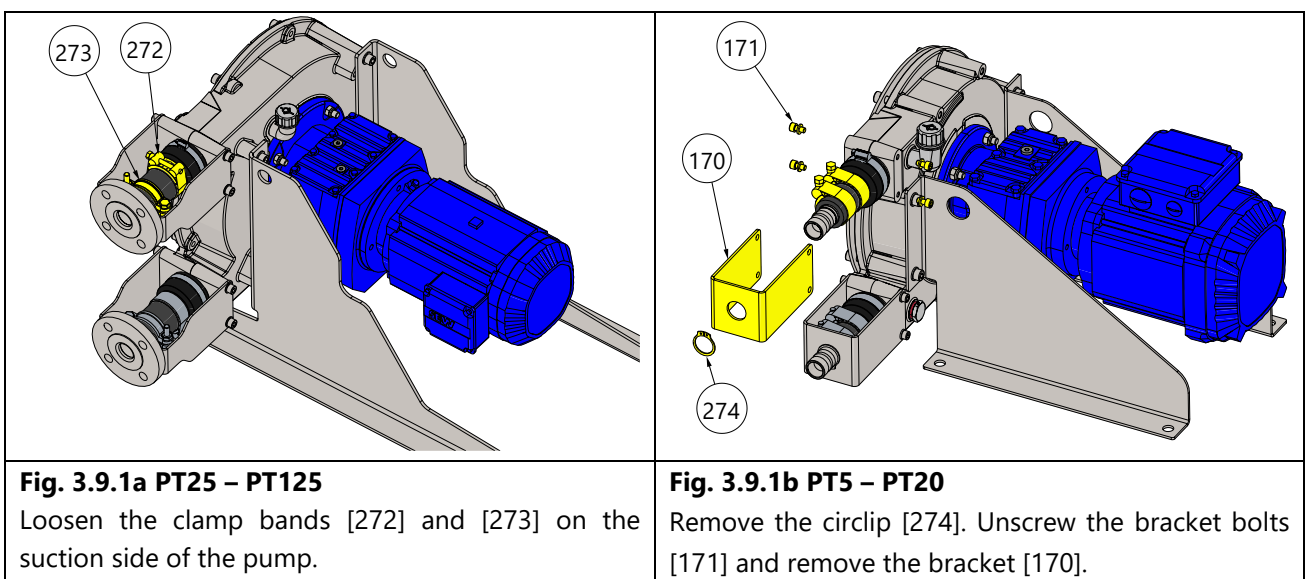

3. MAINTENANCE

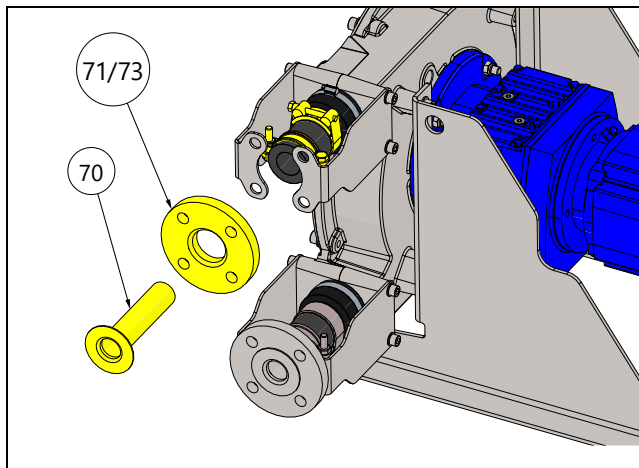

Fig. 3.9.2
Remove the insert [70] and, if applicable, the flange ring [71/73].

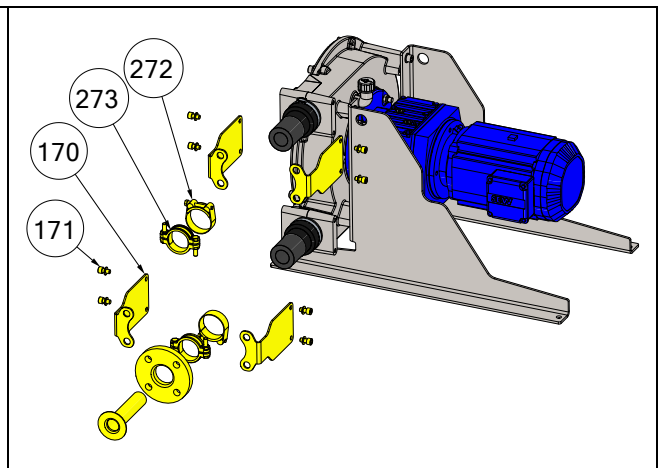

Fig. 3.9.3a PT25 – PT125
Follow steps 3.9.1a and 3.9.2 on the discharge side of the pump. Additionally, unscrew the bracket bolts [171] and remove the brackets [170]. Remove the clamp bands [272] and [273].

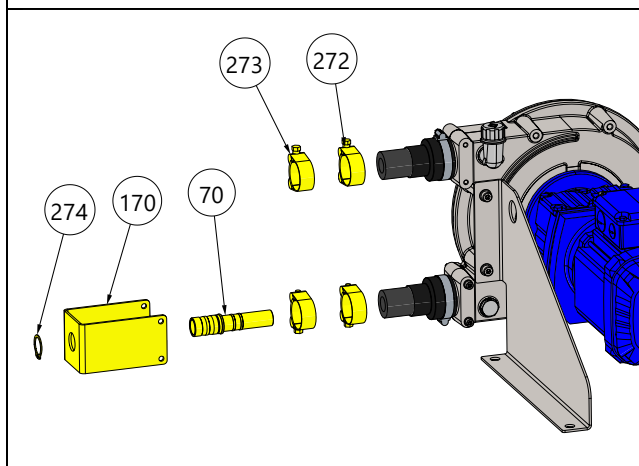

Fig. 3.9.3b PT5 – PT20
Follow steps 3.9.1b and 3.9.2 on the discharge side of the pump. Additionally, remove the clamp bands [272] and [273].

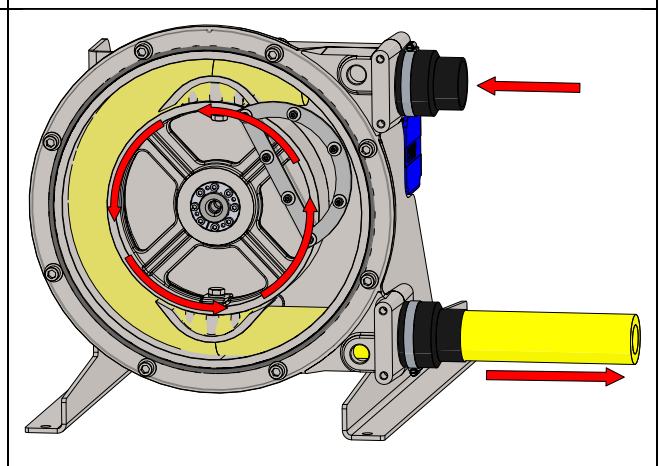

Fig. 3.9.4
Start and stop the motor repeatedly in short bursts (jog run) to extract the hose on the discharge side of the pump.
NOTE! During this operation, make sure no one is standing directly in front of the pump connections as the hose can come out of the casing at significant speed and cause severe injury to the operator.

3. MAINTENANCE

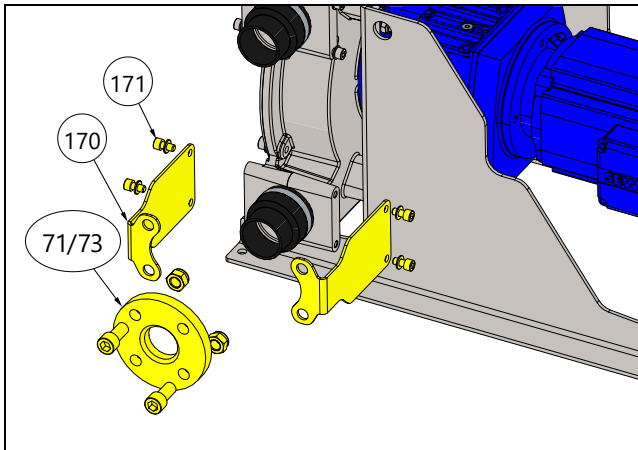

Fig. 3.9.5a PT25 – PT125
Pre-assemble the flange ring [71/73] using two bolts on the discharge side of the pump.

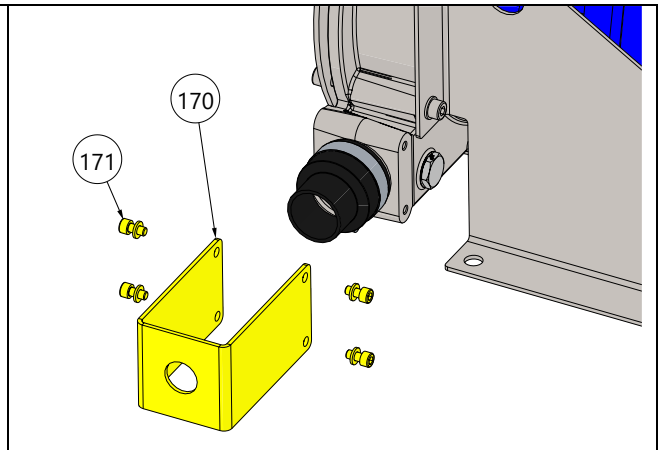

Fig. 3.9.5b PT5 – PT20
Pre-assemble the bracket [170] on the discharge side of the pump.

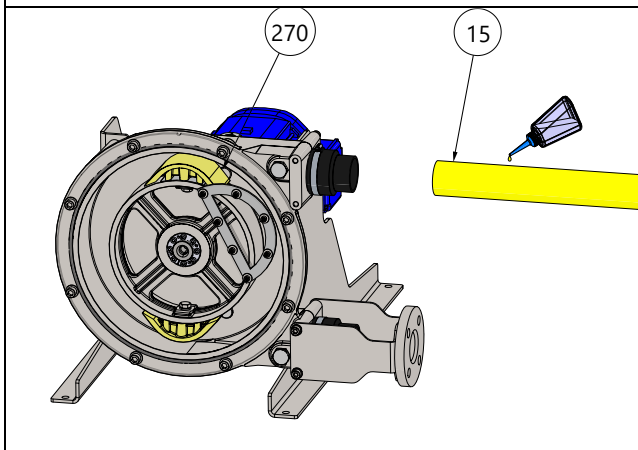

Fig. 3.9.6
Clean the new hose [15] thoroughly before assembly. Slightly lubricate the hose [15] and the inside of the boot cover [270] with Tapflo lubricant.

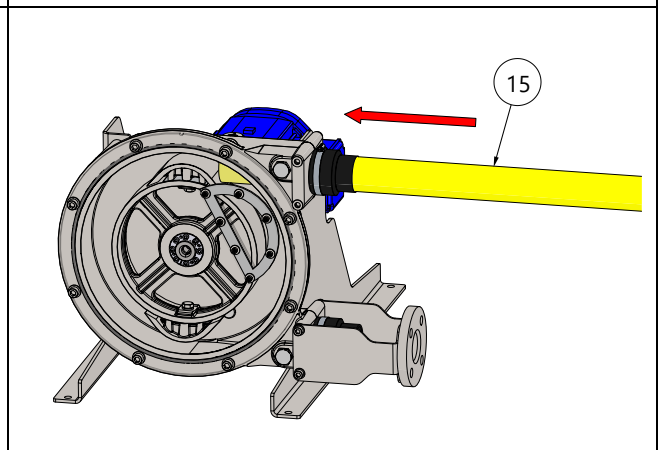

Fig. 3.9.7
Insert the hose [15] by hand to the suction port of the pump.

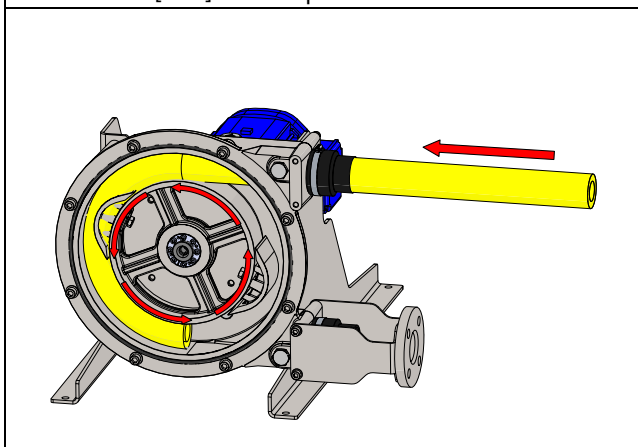

Fig. 3.9.8
While pushing in the hose jog run the motor. The shoes [92] / rotor [90] will guide the hose through the pump into the suction port.

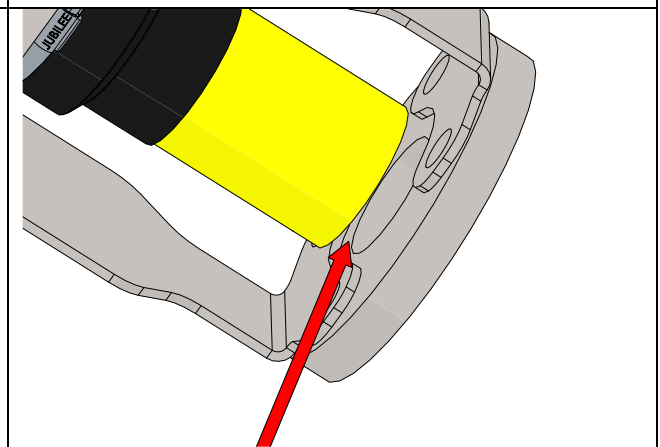

Fig. 3.9.9
Guide the hose [15] to the discharge flange ring [71/73].

3. MAINTENANCE

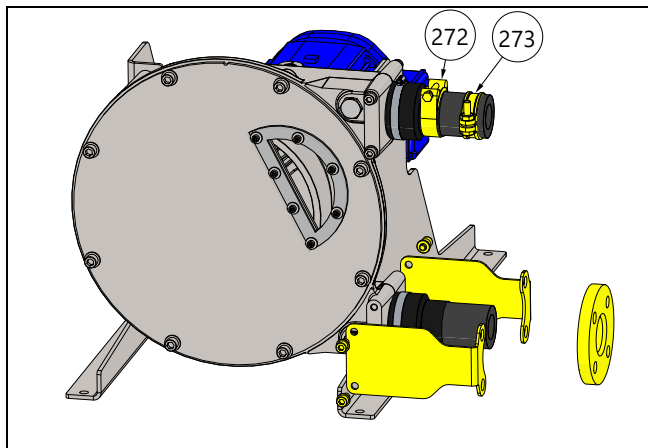

Fig. 3.9.10
 Insert the clamp bands [272] and [273] on the suction side of the pump.
 Disassemble the flange ring and brackets on the discharge side.

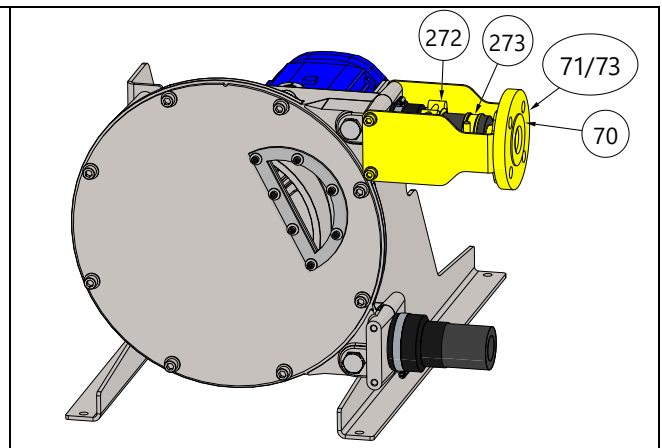

Fig. 3.9.11a PT25-PT125
 Assemble the brackets [170]. Assemble the insert [70] with the flange ring [71/73] into the hose and tighten the clamp bands [272] and [273].
NOTE! Tapflo lubricant may be used to ease assembly of the insert into the hose.

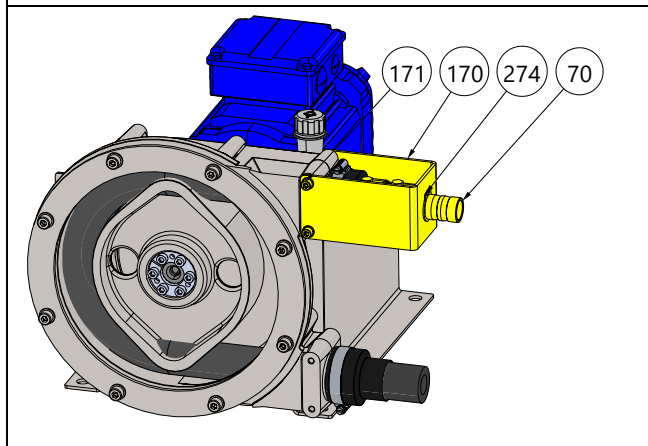

Fig. 3.9.11b PT5-PT20
 Insert the suction side clamp bands [272] and [273] on the hose. Assemble the insert [70] into the hose. Fix the bracket [170] with the mounting bolts [171] and block the insert with the circlip [274]. Tighten the clamp bands.
NOTE! Tapflo lubricant may be used to ease assembly of the insert into the hose.

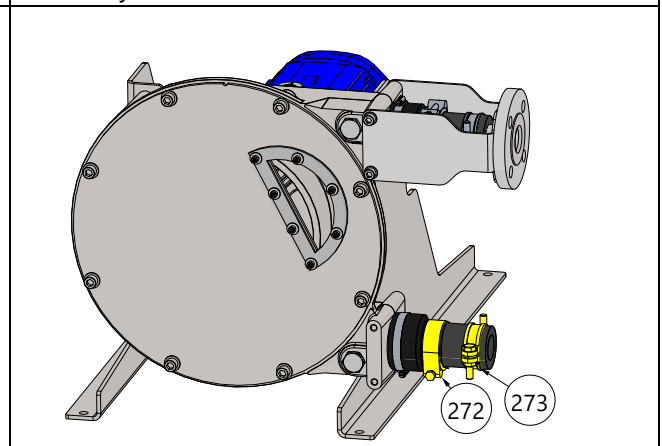
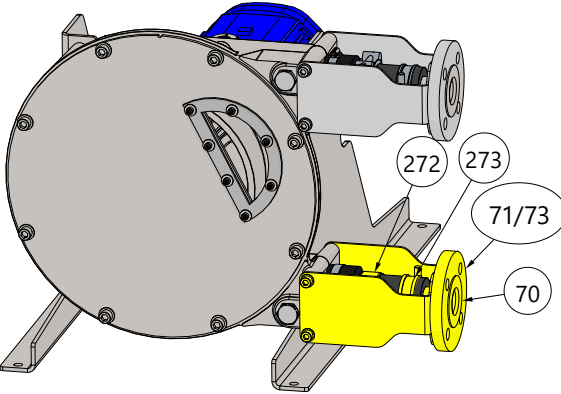
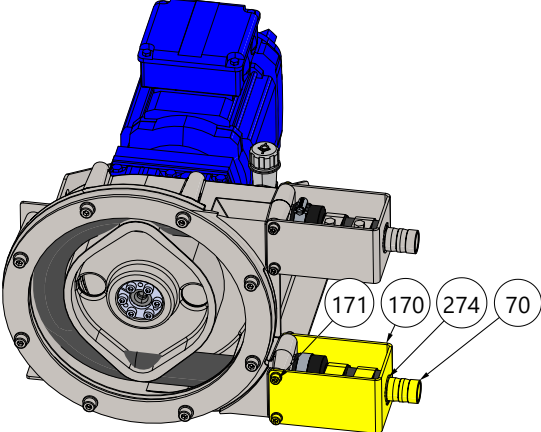
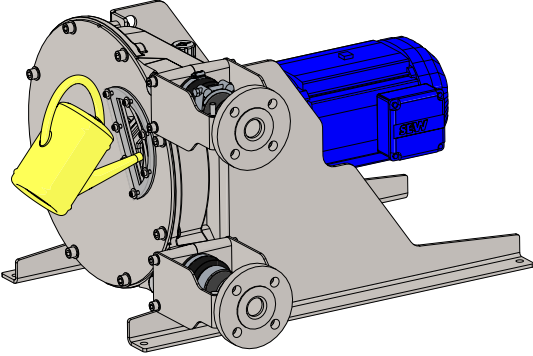

Fig. 3.9.12
 Insert the clamp bands [272] and [273] on the discharge side of the pump.

3. MAINTENANCE

	
<p>Fig. 3.9.13a PT25 – PT125 Assemble the brackets [170]. Assemble the insert [70] into the hose and tighten the clamp bands [272] and [273]. NOTE! Tapflo lubricant may be used to ease assembly of the insert into the hose</p>	<p>Fig. 3.9.13b PT5 – PT20 Insert the discharge side clamp bands [272] and [273] on the hose. Assemble the insert [70] into the hose. Fix the bracket [170] with the mounting bolts [171] and block the insert with the circlips [274]. Tighten the clamp bands. NOTE! Tapflo lubricant may be used to ease assembly of the insert into the hose.</p>
	
<p>Fig. 3.9.14 Fill the pump with lubricant – see section 3.7. “Casing emptying and lubricant filling procedure”.</p>	

The hose is now re-assembled. Make sure to open the suction and discharge valves before pump start-up. Check the direction of rotation of the motor. Check for any lubricant leakage form the pump casing.

3.10. Pump casing cleaning procedure

When a hose rupture has occurred, the pump casing and the lubricant inside the pump will be contaminated. In such case cleaning of the pump casing is required.

NOTE! Proceed with this procedure only after familiarizing oneself with the instructions at the beginning of chapter 3. “Maintenance” and all safety instruction in chapter 1.8. “Health and safety”.

3. MAINTENANCE

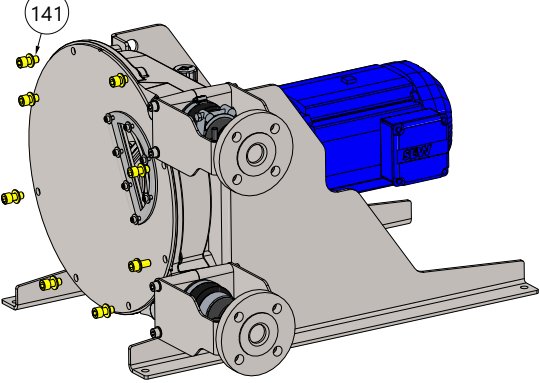
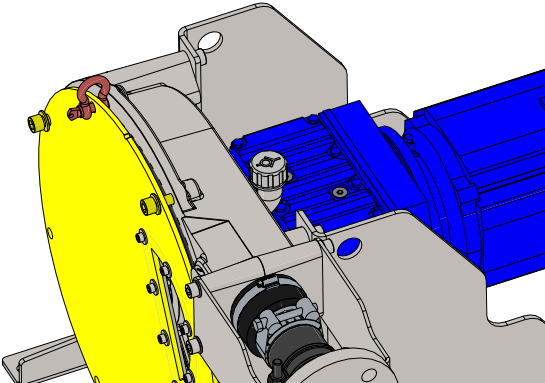
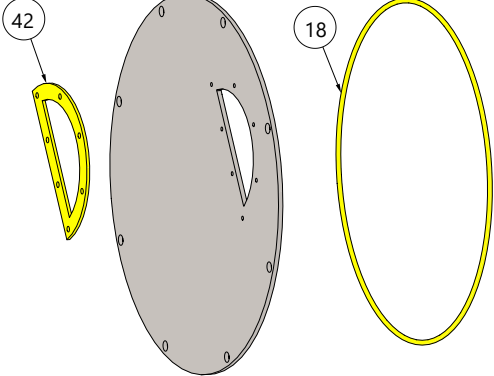
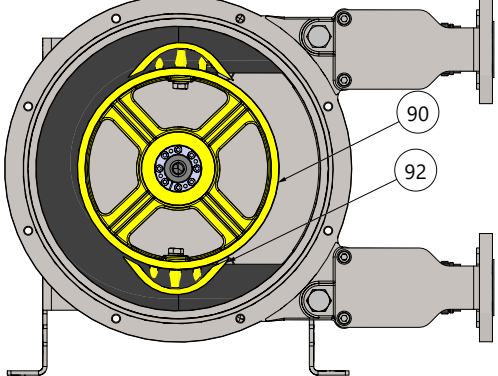
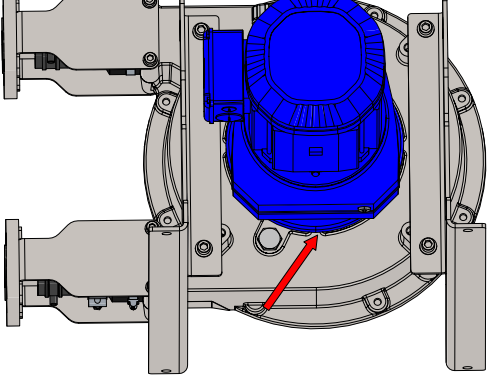
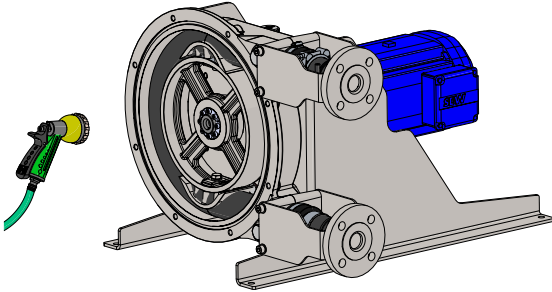
	
<p>Fig. 3.10.1 Remove the front cover mounting bolts [141], leaving two of them partially fastened to avoid accidental falling off of the pump.</p>	<p>Fig. 3.10.2 Retract the front cover [12] slightly and instal a shackle in one of the top bolt holes NOTE! PT80 – PT125 pumps are equipped with a dedicated lifting lug on top of the front cover.</p>
	
<p>Fig. 3.10.3 Check condition of casing gasket [18] and revision windows gasket [42]. Replace if necessary.</p>	<p>Fig. 3.10.4 Check condition of the rotor [90] / shoes [92] and replace if necessary.</p>
	
<p>Fig. 3.10.5 Check condition of the shaft seal [161] and seal ring [162] and replace if necessary.</p>	<p>Fig. 3.10.6 Wash the casing with water and remove any debris left inside the casing. Dry the pump casing thoroughly with pressurized air and reassemble the pump cover.</p>

3. MAINTENANCE

3.11. Shoe shimming – PT25 – PT125

During pump operation as the hose starts to wear, internal leakage inside the hose can occur. In order to avoid this, additional shims can be added under the shoes in order to increase the compression of the hose. This is an important procedure, as internal leakage reduces the hose lifetime and affect the pump flow. The shoe shimming varies based on pump rotation speed, discharge pressure and liquid viscosity. This operation can be done without complete pump disassembly, through the revision window.

NOTE! Proceed with this procedure only after familiarizing oneself with the instructions at the beginning of chapter 3. "Maintenance", 6.3 "Shimming tables" all safety instruction in chapter 1.8. "Health and safety".

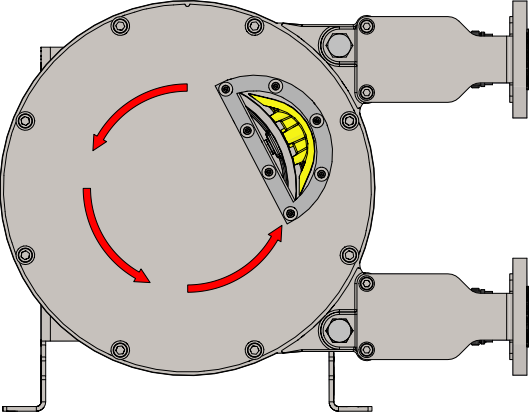
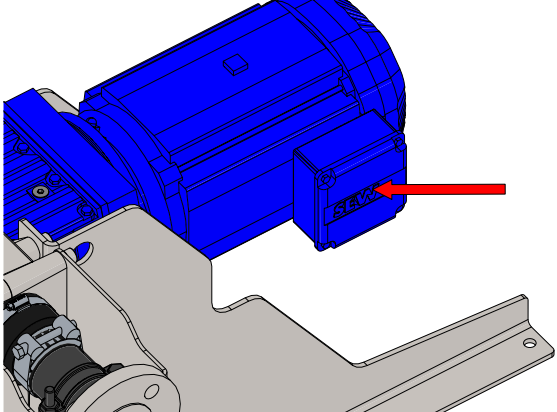
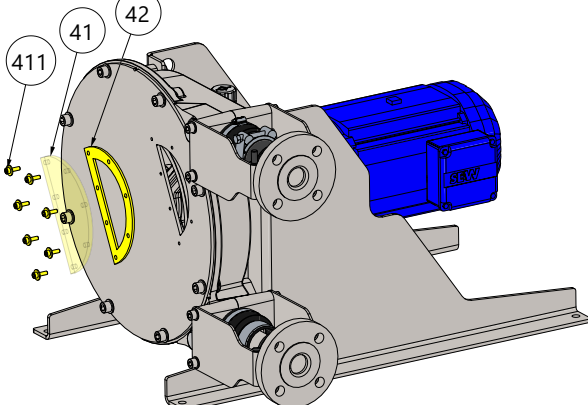
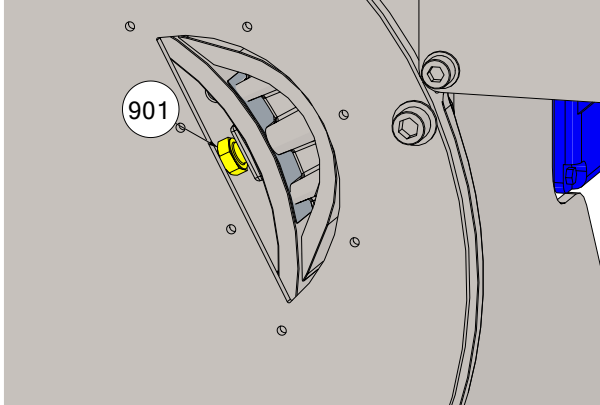
	
<p>Fig. 3.11.1 Start and stop the motor repeatedly in short bursts (jog run) to position the shoe [92] in front of the revision window [41].</p>	<p>Fig. 3.11.2 Disconnect power supply from the motor.</p>
	
<p>Fig. 3.11.3 Unscrew the revision window bolts [411] and remove the revision window [41] with its gasket [42]. NOTE! Check condition of the gasket and replace if necessary.</p>	<p>Fig. 3.11.4 Slightly unscrew the shoe mounting bolt [901].</p>

3. MAINTENANCE

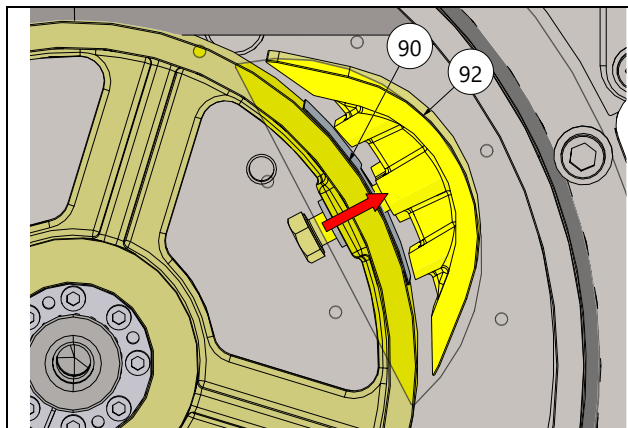

Fig. 3.11.5
Lift the shoe [92] slightly from the rotor [90].

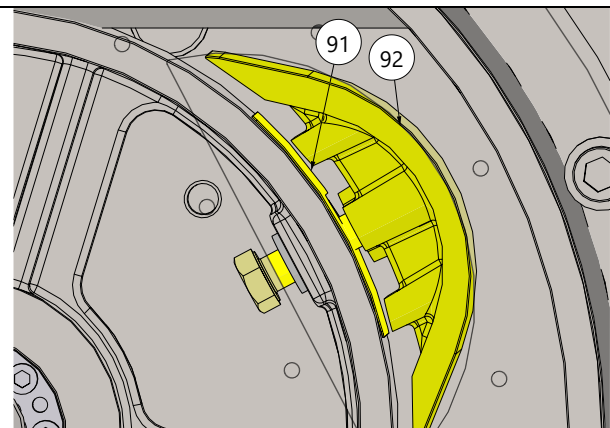

Fig. 3.11.6
In this position you are able to insert or withdraw the shims [91] form underneath the shoe [92].
NOTE! See chapter 6.3. "Shimming tables" for more information.

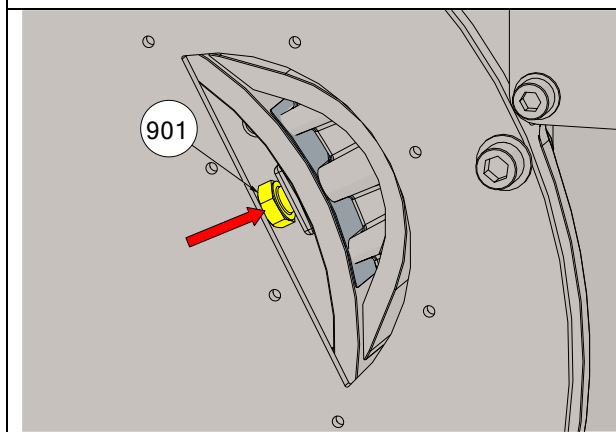

Fig. 3.11.7
Re-tighten the shoe mounting bolts [901] with appropriate torque.

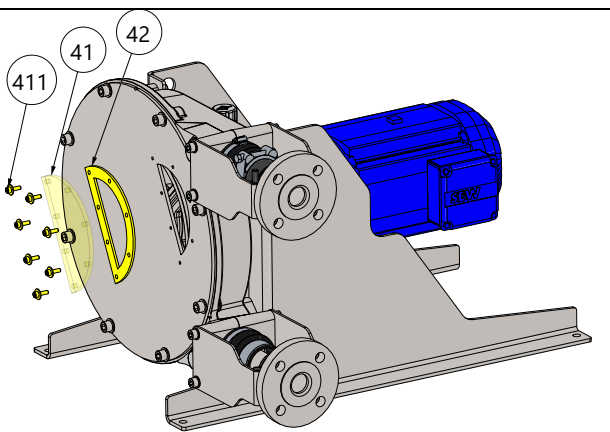

Fig. 3.11.8
Re-assemble the revision window [41] with its gasket [42].

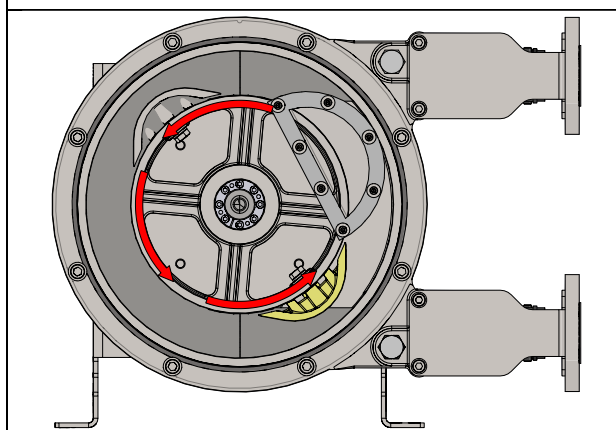

Fig. 3.11.9
Re-connect the power to the motor and jog run until the other shoe comes in front of the revision window.

3.11.10
Disconnect power form the motor and repeat operations **3.11.3 – 3.11.8** on the other shoe.
NOTE! There should always be the same amount of shims on both shoes.

3. MAINTENANCE

3.12. Rotor/shoe assembly



When assembling rotor on the shaft, it is important to provide correct "C" distance between the rotor and both pump casing and front cover.

When replacing the rotor/shoe with a new one, measure the rotor/shoe width to ensure that the "C" distance can be maintained.

Pump size	Track width A [mm]	Shoe/rotor* width B [mm]	Distance C [mm]
PT5	43	35	4
PT10	43	36	3,5
PT15	53,5**	47**	3,25**
	53,5***	48***	2,75***
PT20	53,5**	47**	3,25**
	53,5***	48***	2,75***
PT25	71,5	60	5,75
PT32	82	70	6
PT38	82	77	2,5
PT40	90	80	5
PT51	116	110	3
PT60	116	110	3
PT65	156	135	10,5
PT80	164	145	9,5
PT80L	164	148	8
PT100	200	185	7,5
PT125	250	220	15

*PT5-PT20 – rotor; PT25-PT125 – shoe

**two-lobe rotor

***three-lobe rotor

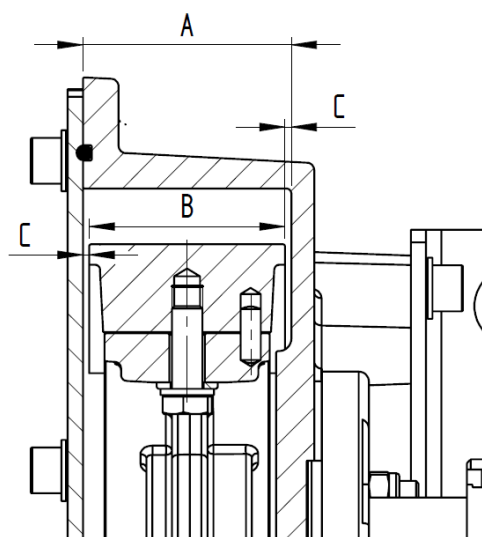

Shoe

Make sure that shoe and rotor are aligned properly. The shoe side edge should be parallel to the rotor edge.



Clamping set

It is crucial to maintain the proper sequence of tightening the clamping set screws. Otherwise, there is a possibility of the clamping set bush getting stuck in the wrong position, even when using the recommended tightening torque. See section 6.5. "Tightening torques" for required torque.

NOTE! As the clamping set tightens, the rotor may slightly shift on the gearmotor shaft. Adjust the position of the rotor so that after tightening, the distance "C" is maintained.

3. MAINTENANCE

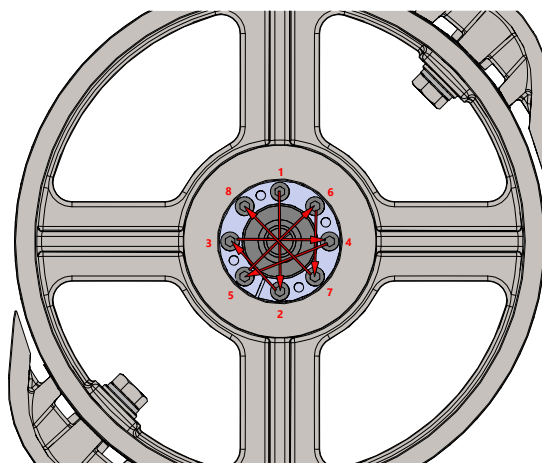

3.13. Casing assembly directions

The standard pump configuration includes casing directed to the right. However, other positions are also possible.

<p>Fig. 3.13.1 Right direction Standard casing direction</p>	<p>Fig. 3.13.1 Left direction The pump is designed in such a way that it can be easily directed to the left without any modifications. By using the code 2L when ordering the pump, the housing will be installed in the left direction.</p>
<p>Fig. 3.13.1 Upwards direction Directing casing upwards requires certain modifications that need to be made at the ordering stage. Use the code 2U for such a configuration.</p> <p>NOTE! This position is not recommended for fluids with solid particles due to the possibility of their accumulation in the hose due to gravity.</p> <p>NOTE! Due to the increased risk of hose rupture, directing the housing upwards is not permitted in potentially explosive atmospheres (ATEX).</p>	

4. OPTIONS AND ACCESSORIES

4. OPTIONS AND ACCESSORIES

4.1. **Clean PRO PUMP**

The CIP pump is equipped with a special rotor design that allow the shoes to retract when changing the direction of rotation and thus easy cleaning of the pump. Apart from that the pump has several other features that distinguish it from a standard pump execution:

- Stainless steel brackets, inserts, clamps and pump feet
- Food grade hose material
- White food grade coating of the gearmotor and pump casing

4.2. **Pump trolleys**

If the hose pump is required to be a mobile device, a range of industrial trolleys are available. They are designed to enable mobility but also stable and easy operation of the delivered devices. Thanks to the trolleys the pumps can be easily transported and used in many applications and locations. Because some of the pump are pretty big, the trolleys are available for **PT15**, **PT20**, **PT25**, **PT32**, **PT38** and **PT40** pumps. The trolleys are made of sandblasted AISI 304 stainless steel. A variety of options is also available, including: ATEX, ON/OFF switch, built-on frequency inverter, supply cable with 3-phase plug.

For more details see the "Mobile Pump Solutions" Info letter under this [LINK](#).



4.3. **Frequency inverters**

The frequency inverters are used regulate the motor speed and therefore the capacity of the pump. They can be purchased as standalone units to be installed separately of the pump or pre-installed in a cabinet including a control system or built on a trolley.

For more details see the "Frequency inverters" Info letter under this [LINK](#).



4.4. **Hose leak detector**

The rupture of the hose, which is a wearing part, creates a leakage of the pumped liquid. Hose detectors make it possible to detect these leakages and stop the pump upon hose rupture. The system is based either on a pressure switch or capacitive sensor (depending on pump size) and is available for all pump sizes. Apart from the sensor itself, it includes a threaded reduction and a connection cable of desired length.

For more details see the "Hose Leak Detectors" Info letter under this [LINK](#).



5. SPARE PARTS

5. SPARE PARTS

Full part number consist of three parts, pump type ("15" for PT pumps), pump size (e.g. 025, 040, ...) and part position which corresponds to the number in the drawing e.g. **15-xxx-18**:

15 – PT high pressure hose pump

xxx – pump size

18 – part position

NOTE! Use only Original Tapflo spare parts. Using counterfeit parts creates a risk of improper operation, increases possibility of breakdown and voids warranty terms.

5.1. Exploded view PT5 – PT20

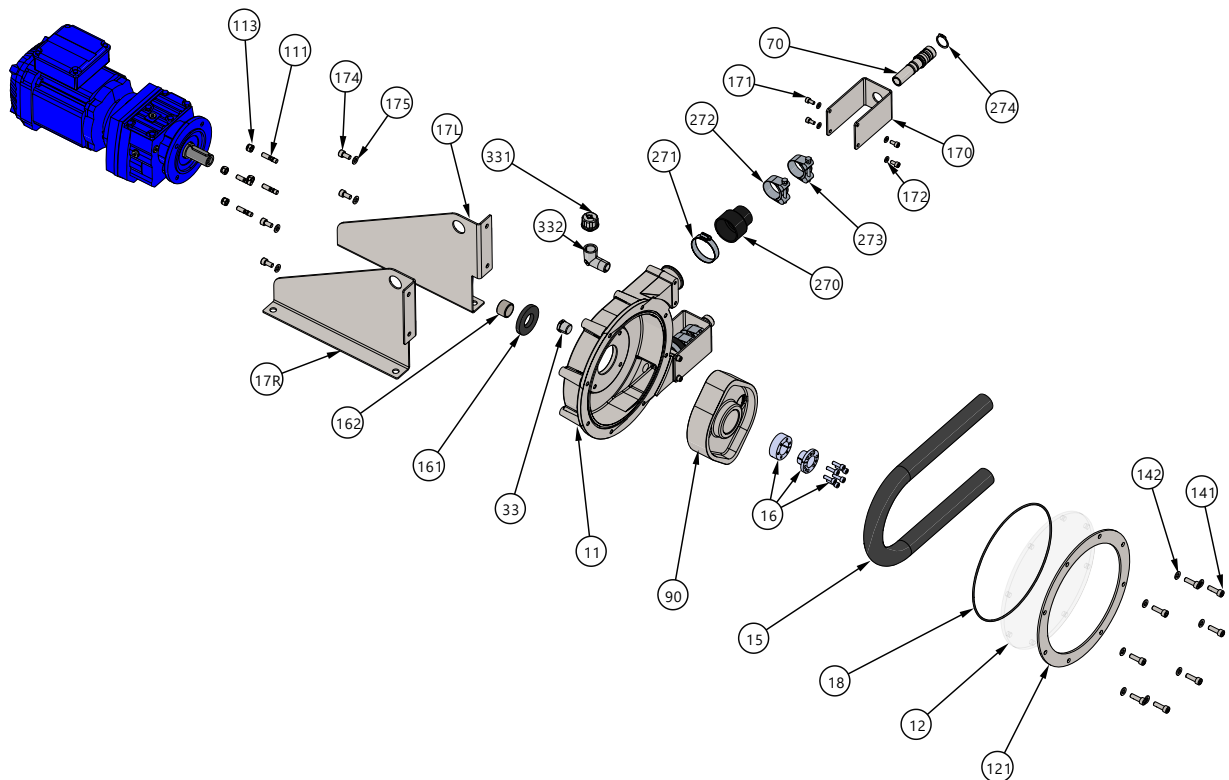

5.2. Spare parts list PT5 – PT20

Pos.	Q-ty	Description	Material
11	1	Pump casing	Nodular cast iron
111	4	Gearmotor mounting stud bolts	A2-70
113	4	Gearmotor mounting nuts	A4
12	1	Front cover	Polycarbonate, AISI 340L
121	1	Front cover reinforcement flange	Galvanized steel
141	4/8 ¹⁾	Front cover mounting bolt	A4-70
142	4/8 ¹⁾	Front cover mounting washer	A4-70
15	1	Hose	NR, NBR, EPDM
16	1	Clamping set	Steel, cast iron
161	1	Shaft seal	NBR, EPDM

5. SPARE PARTS

162	1	Seal ring	1.7035 steel
16S	1	Complete clamping set (16+161+162)	Various
17L	1	Pump foot – left	Galvanized steel, AISI 340L
17R	1	Pump foot – right	Galvanized steel, AISI 340L
170	2	Connection bracket	Galvanized steel, AISI 304L
171	8	Connection bracket bolt	A4-70
172	8	Connection bracket washer	A4-70
174	4	Casing mounting bolt	A4-70
175	4	Casing mounting washer	A4-70
18	1	Casing gasket	NBR, EPDM
270	2	Boot cover	EPDM, NBR
271	2	Clamp band big - casing	AISI 304
272	2	Clamp band small – boot cover	AISI 316
273	2	Clamp band small - hose	AISI 316
274	2	Circlip	Zinc plated steel
33	2/1 ³⁾	Drain plug	AISI 316L
331 ²⁾	1	Breather plug	PA/NBR/AISI304
332 ²⁾	1	Breather plug elbow	AISI 316L
70	2	Insert	AISI 316L, PP-H
90	1	Rotor	Nodular cast iron / Aluminum

1) **4** for PT5-PT10 / **8** for PT15-PT20

2) Only for PT15-PT20

3) **2** for PT5-PT10 / **1** for PT15-PT20

5.3. Spare parts KITS PT5 – PT20

5.3.1. Complete clamping set for PT5-PT20 – 15-020-16S

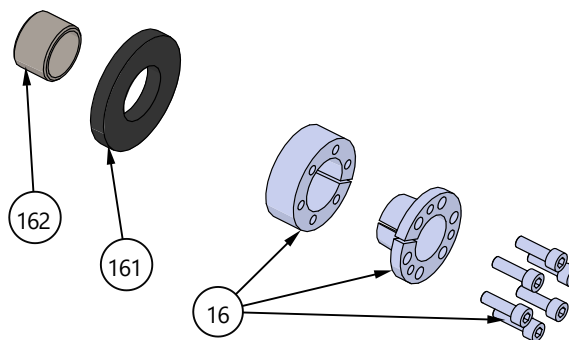

Pos.	Q-ty	Description	Material
16	1	Clamping set	Steel, cast iron
161	1	Shaft seal	NBR, EPDM
162	1	Seal ring	1.7035 steel

For interactive drawing visit the [LINK](#)

5. SPARE PARTS

5.4. Exploded view PT25 – PT38

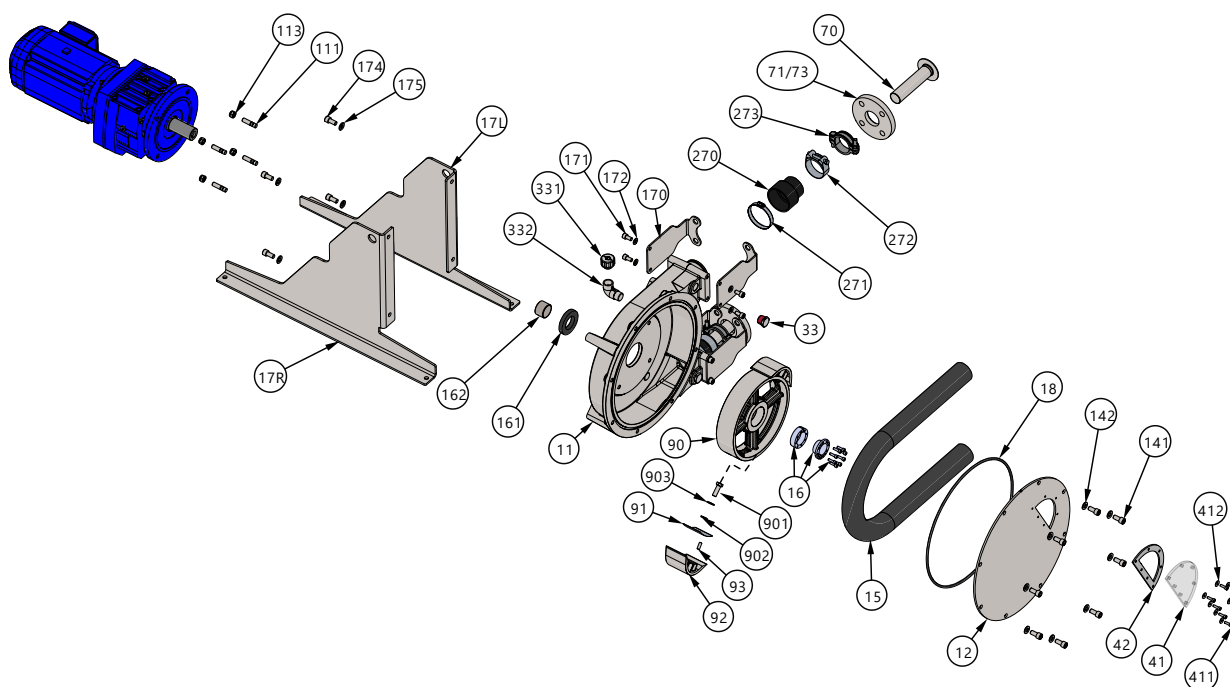

For interactive exploded view go [HERE](#)

5.5. Spare parts list PT25 – PT38

Pos.	Q-ty	Description	Material
11	1	Pump casing	Nodular cast iron
111	4	Gearmotor mounting stud bolts	A2-70 / Zinck plated steel
113	4	Gearmotor mounting nuts	A4
12	1	Front cover	Galvanized steel
141	8	Front cover mounting bolt	A4-70
142	8	Front cover mounting washer	A4-70
15	1	Hose	NR, NBR, EPDM
16	1	Clamping set	Steel, cast iron
161	1	Shaft seal	NBR, EPDM
162	1	Seal ring	1.7035 steel
16S	1	Complete clamping set (16+161+162)	Various
17L	1	Pump foot – left	Galvanized steel, AISI 340L
17R	1	Pump foot – right	Galvanized steel, AISI 340L
170	4	Connection bracket	Galvanized steel, AISI 304L
171	8	Connection bracket bolt	A4-70
172	8	Connection bracket washer	A4-70
174	4	Casing mounting bolt	A4-70
175	4	Casing mounting washer	A4-70
18	1	Casing seal	EPDM, NBR
270	2	Boot cover	EPDM, NBR
271	2	Clamp band big – casing	AISI 304
272	2	Clamp band small – hose	AISI 316

5. SPARE PARTS

273	2	2-piece hose clamp	Zinc plated steel
33	3	Drain plug	AISI 316L
331	1	Breather plug	PA/NBR/AISI304
332	1	Breather plug elbow	AISI 316L
41	1	Revision window	Polycarbonate, AISI 304 ²⁾
42	1	Revision window gasket	NBR
411	6/7 ¹⁾	Revision window mounting bolt	A4-70
412	6/7 ¹⁾	Revision window mounting washer	A4-70
70	2	Flange pipe / insert	AISI 316L, PP-H
71/73	2	Flange ring ANSI / DIN	AISI 316L
90	1	Rotor	Nodular cast iron
91	8	Shim	AISI 304L
92	2	Shoe	Nodular cast iron
93	2	Shoe centering pin	A2
901	2	Shoe mounting bolt	A4-70
902	2	Shoe mounting spring washer	A4-80
903	2	Shoe mounting washer	A4-70

1) **6** for PT25 / **7** for PT32-PT38

2) **Polycarbonate:** non-ATEX pumps / **AISI 304:** ATEX pumps

5.6. Spare parts KITs PT25 – PT38

Complete clamping set for PT25 – 15-025-16S

Complete clamping set for PT32-PT38 – 15-038-16S

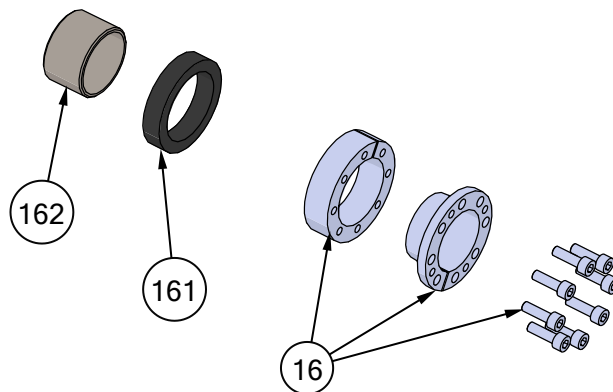

Pos.	Q-ty	Description	Material
16	1	Clamping set	Steel, cast iron
161	1	Shaft seal	NBR, EPDM
162	1	Seal ring	1.7035 steel

For interactive drawing visit the [LINK](#)

5. SPARE PARTS

5.7. Exploded view PT40 – PT60

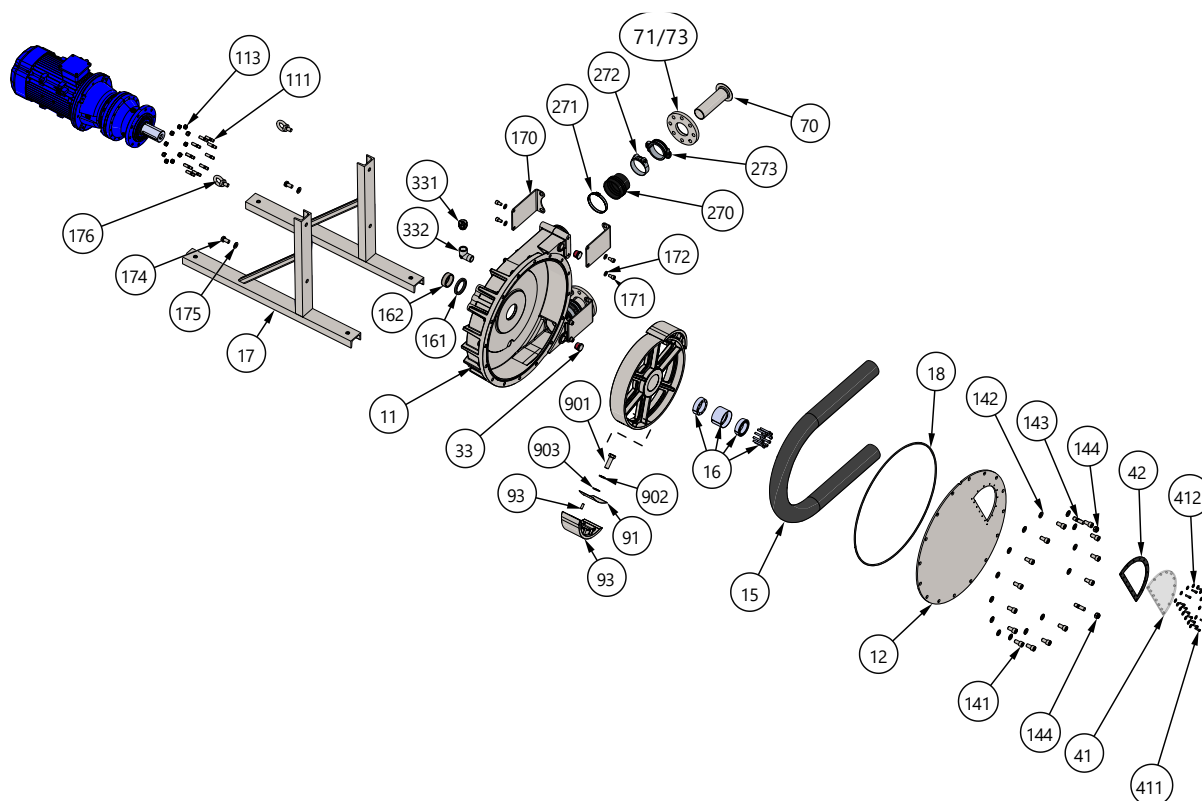

5.8. Spare parts list PT40 – PT60

Pos.	Q-ty	Description	Material
11	1	Pump casing	Nodular cast iron
111	4/10 ²⁾	Gearmotor mounting stud bolts	A2-70 / Zinck plated steel
113	4/10 ²⁾	Gearmotor mounting nuts	A4
12	1	Front cover	Galvanized steel
141	10/14 ³⁾	Front cover mounting bolt	A4-70
142	10/14 ³⁾	Front cover mounting washer	A4-70
143	2	Front cover stud bolts	Zinck plated steel
144	2	Front cover stud bolt nut	A4
15	1	Hose	NR, NBR, EPDM
16	1	Clamping set	Steel, cast iron
161	1	Shaft seal	NBR, EPDM
162	1	Seal ring	1.7035 steel
16S	1	Complete clamping set (16+161+162)	Various
17	2	Pump foot	Galvanized steel, AISI 340L
170	4	Connection bracket	Galvanized steel, AISI 304L
171	8	Connection bracket bolt	A4-70
172	8	Connection bracket washer	A4-70
174	2	Casing mounting bolt	A4-70
175	2	Casing mounting washer	A4-70
176	2	Eye bolt	Zinck plated steel
18	1	Casing seal	EPDM, NBR

5. SPARE PARTS

270	2	Boot cover	EPDM, NBR
271	2	Clamp band big - casing	AISI 304
272	2	Clamp band small – hose	AISI 316
273	2	2-piece hose clamp	Zinc plated steel
33	3	Drain plug	AISI 316L
331	1	Breather plug	PA/NBR/AISI 304
332	1	Breather plug elbow	AISI 316L
41	1	Revision window	Polycarbonate, AISI 304 ⁴⁾
42	1	revision window gasket	NBR
411	10/15 ¹⁾	Revision window mounting bolt	A4-70
412	10/15 ¹⁾	Revision window mounting washer	A4-70
70	2	Flange pipe / insert	AISI 316L, PP-H
71/73	2	Flange ring ANSI / DIN	AISI 316L
90	1	Rotor	Nodular cast iron
91	8	Shim	AISI 304L
92	2	Shoe	Nodular cast iron
93	2	Shoe centering pin	A2
901	2	Shoe mounting bolt	A4-70
902	2	Shoe mounting spring washer	A4-80
903	2	Shoe mounting washer	A4-70

- 1) **10** for PT40 / **15** for PT51-PT60
- 2) **4** PT40 / **10** for PT51-PT60
- 3) **10** for PT40 / **14** for PT51-PT60
- 4) **Polycarbonate:** non-ATEX pumps / **AISI 304:** ATEX pumps

5.9. Spare parts KITs PT40 – PT60

Complete clamping set for PT40 – 15-040-16S

Complete clamping set for PT51-PT60 – 15-060-16S

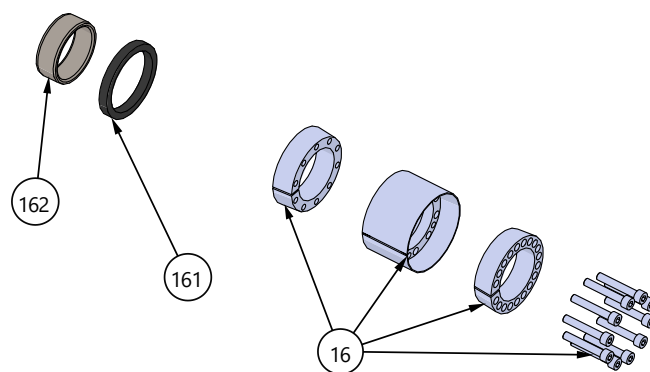

Pos.	Q-ty	Description	Material
16	1	Clamping set	Steel, cast iron
161	1	Shaft seal	NBR, EPDM
162	1	Seal ring	1.7035 steel

For interactive drawing visit the [LINK](#)

5. SPARE PARTS

5.10. Exploded view PT65 – PT80L

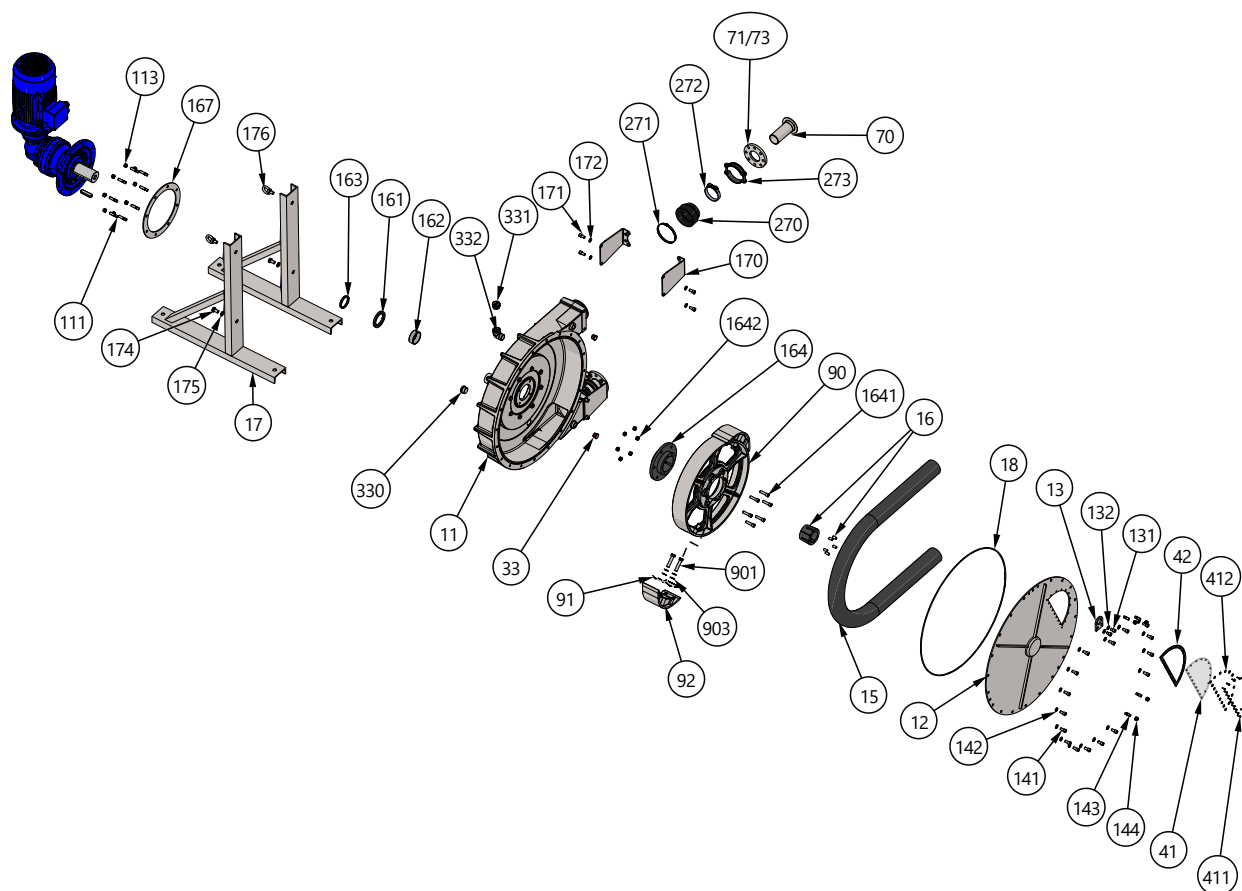

5.11. Spare parts list PT65 – PT80L

Pos.	Q-ty	Description	Material
11	1	Pump casing	Nodular cast iron
111	8	Gearmotor mounting stud bolts	Zinck plated steel
113	8	Gearmotor mounting nuts M16	A4
12	1	Front cover	Galvanized steel
13	1 ²⁾	Lifting ring	Galvanized steel
131	2 ²⁾	Lifting ring mounting bolts	A4-70
132	2 ²⁾	Lifting ring mounting washers	A4-70
141	16	Front cover mounting bolt M16x35	A4-70
142	16	Front cover mounting washer M16	A4-70
143	4	Front cover stud bolts M16x30	Zinck plated steel
144	4	Front cover stud bolt nut M16	A4
15	1	Hose	NR, NBR, EPDM
16	1	Taper bush	Steel, cast iron
161	1	Shaft seal	NBR, EPDM
162	1	Seal ring	1.7035 steel
163	1	Spacer ring	1.7035 steel
164	1	Taper bush flange	Cast iron
1641	6	Taper bush flange mounting bolts	Zinc plated steel
1642	6	Taper bush flange mounting nuts M16	A4
167	1 ²⁾	Centering flange	Steel

5. SPARE PARTS

17	2	Pump foot	Galvanized steel, AISI 340L
170	4	Connection bracket	Galvanized steel, AISI 304L
171	8	Connection bracket bolt M12x20	A4-70
172	8	Connection bracket washer M12	A4-70
174	2	Casing mounting bolt M20x35	A4-70
175	2	Casing mounting washer	A4-70
176	2	Eye bolt	Zinck plated steel
18	1	Casing seal	EPDM, NBR
270	2	Boot cover	EPDM, NBR
271	2	Clamp band big - casing	AISI 304
272	2	Clamp band small – hose	AISI 316
273	2	2-piece hose clamp	Zinc plated steel
33	2	Drain plug – small	AISI 316L
330	1	Drain plug – big	AISI 316L
331	1	Breather plug	PA/NBR/AISI304
332	1	Breather plug elbow	AISI 316L
41	1	Revision window	Polycarbonate, AISI 304 ⁴⁾
42	1	Revision window gasket	NBR
411	18	Revision window mounting bolt M6x20	A4-70
412	18	Revision window mounting washer	A4-70
70	2	Flange pipe / insert	AISI 316L, PP-H
71/73	2	Flange ring ANSI / DIN	AISI 316L
90	1	Rotor	Nodular cast iron
91	8	Shim	AISI 304L
92	2	Shoe	Nodular cast iron
93	2 ³⁾	Shoe centering pin	A2
901	2/4 ¹⁾	Shoe mounting bolt M20x75	A4-70
902	2/4 ¹⁾	Shoe mounting spring washer M20	A4
903	2 ³⁾	Shoe mounting washer M20	Zinc plated steel

1) **2** for PT65-PT80 / **4** for PT80L

2) Only for PT80L

3) Only for PT65-PT80

4) **Polycarbonate:** non-ATEX pumps / **AISI 304:** ATEX pumps

5. SPARE PARTS

5.12. Exploded view PT100

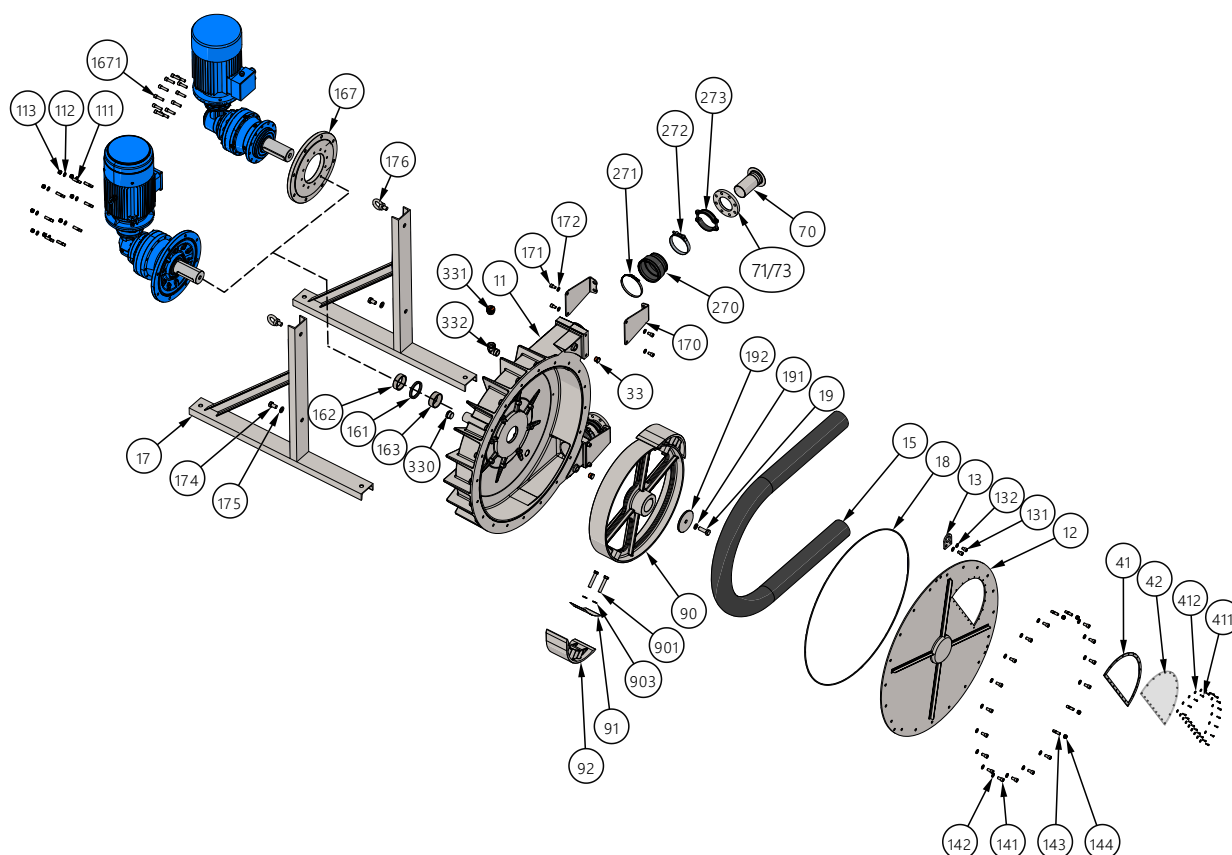

5.13. Spare parts list PT100

Pos.	Q-ty	Description	Material
11	1	Pump casing	Nodular cast iron
111	8	Gearmotor mounting stud bolts	Zinck plated steel
113	8	Gearmotor mounting nuts M16	A4
12	1	Front cover	Galvanized steel
13	1	Lifting ring	Galvanized steel
131	2	Lifting ring mounting bolts	A4-70
132	2	Lifting ring mounting washers	A4-70
141	16	Front cover mounting bolt M16x35	A4-70
142	16	Front cover mounting washer M16	A4-70
143	4	Front cover stud bolts M16x30	Zinck plated steel
144	4	Front cover stud bolt nut M16	A4
15	1	Hose	NR, NBR, EPDM
161	1	Shaft seal	NBR, EPDM
162	1	Seal ring	1.7035 steel
163	1	Spacer ring	1.7035 steel
167	1 ⁴⁾	Centering flange	Steel
1671	1 ⁴⁾	Centering flange bolt	A4-70
17	2	Pump foot	Galvanized steel, AISI 340L
170	4	Connection bracket	Galvanized steel, AISI 304L

5. SPARE PARTS

171	8	Connection bracket bolt M12x20	A4-70
172	8	Connection bracket washer M12	A4-70
174	2	Casing mounting bolt M20x35	A4-70
175	2	Casing mounting washer	A4-70
176	2	Eye bolt	Zinck plated steel
18	1	Casing seal	EPDM, NBR
19	1	Rotor mounting screw	A4-70
191	1	Rotor mounting washer	A4-70
192	1	Rotor mounting cap	AISI 304
270	2	Boot cover	EPDM, NBR
271	2	Clamp band big - casing	AISI 304
272	2	Clamp band small – hose	AISI 316
273	2	2-piece hose clamp	Zinc plated steel
33	2	Drain plug – small	AISI 316L
330	1	Drain plug – big	AISI 316L
331	1	Breather plug	PA/NBR/AISI304
332	1	Breather plug elbow	AISI 316L
41	1	Revision window	Polycarbonate, AISI 304 ⁶⁾
42	1	Revision window gasket	NBR
411	18	Revision window mounting bolt M6x20	A4-70
412	18	Revision window mounting washer	A4-70
70	2	Flange pipe / insert	AISI 316L, PP-H
71/73	2	Flange ring ANSI / DIN	AISI 316L
90	1	Rotor	Nodular cast iron
91	8	Shim	AISI 304L
92	2	Shoe	Nodular cast iron
93	2 ³⁾	Shoe centering pin	A2
901	2/4 ¹⁾	Shoe mounting bolt M20x75	A4-70
902	2/4 ¹⁾	Shoe mounting spring washer M20	A4
903	2 ³⁾	Shoe mounting washer M20	Zinc plated steel

5) Only for PT100 wit Rossi gearmotor.

6) **Polycarbonate:** non-ATEX pumps / **AISI 304:** ATEX pumps

5. SPARE PARTS

5.14. Exploded view PT125

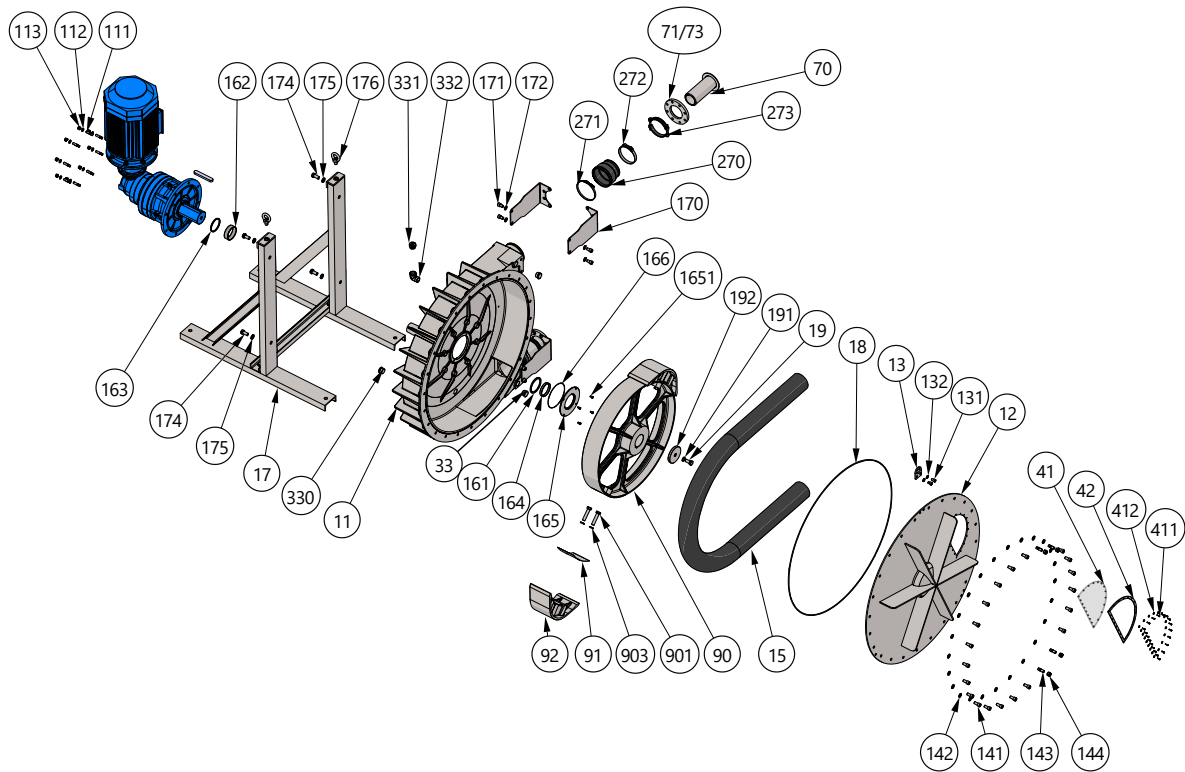

5.15. Spare parts list PT125

Pos.	Q-ty	Description	Material
11	1	Pump casing	Nodular cast iron
111	8	Gearmotor mounting stud bolts	Zinck plated steel
113	8	Gearmotor mounting nuts M16	A4
12	1	Front cover	Galvanized steel
13	1	Lifting ring	Galvanized steel
131	2	Lifting ring mounting bolts	A4-70
132	2	Lifting ring mounting washers	A4-70
141	16	Front cover mounting bolt M16x35	A4-70
142	16	Front cover mounting washer M16	A4-70
143	4	Front cover stud bolts M16x30	Zinck plated steel
144	4	Front cover stud bolt nut M16	A4
15	1	Hose	NR, NBR, EPDM
161	1	Shaft seal	NBR, EPDM
162	1	Seal ring	1.7035 steel
163	1	Spacer ring 130x7	1.7035 steel
164	1	Spacer ring 130x18	1.7035 steel
165	1	Seal flange	Steel
1651	4	Seal flange mounting screw M10x16	A4-70
166	1	Seal flange O-ring	NBR
17	2	Pump foot	Galvanized steel, AISI 340L

5. SPARE PARTS

170	4	Connection bracket	Galvanized steel, AISI 304L
171	8	Connection bracket bolt M12x20	A4-70
172	8	Connection bracket washer M12	A4-70
174	2	Casing mounting bolt M20x35	A4-70
175	2	Casing mounting washer	A4-70
176	2	Eye bolt	Zinck plated steel
18	1	Casing seal	EPDM, NBR
19	1	Rotor mounting screw	A4-70
191	1	Rotor mounting washer	A4-70
192	1	Rotor mounting cap	AISI 304
270	2	Boot cover	EPDM, NBR
271	2	Clamp band big - casing	AISI 304
272	2	Clamp band small – hose	AISI 316
273	2	2-piece hose clamp	Zinc plated steel
33	2	Drain plug – small	AISI 316L
330	1	Drain plug – big	AISI 316L
331	1	Breather plug	PA/NBR/AISI304
332	1	Breather plug elbow	AISI 316L
41	1	Revision window	Polycarbonate
42	1	Revision window gasket	NBR
411	18	Revision window mounting bolt M6x20	A4-70
412	18	Revision window mounting washer	A4-70
70	2	Flange pipe / insert	AISI 316L, PP-H
71/73	2	Flange ring ANSI / DIN	AISI 316L
90	1	Rotor	Nodular cast iron
91	8	Shim	AISI 304L
92	2	Shoe	Nodular cast iron
93	2	Shoe centering pin	A2
901	4	Shoe mounting bolt M20x75	A4-70
902	4	Shoe mounting spring washer M20	A4
903	2	Shoe mounting washer M20	Zinc plated steel

1) **Polycarbonate:** non-ATEX pumps / **AISI 304:** ATEX pumps

5. SPARE PARTS

5.16. Exploded view PTC40

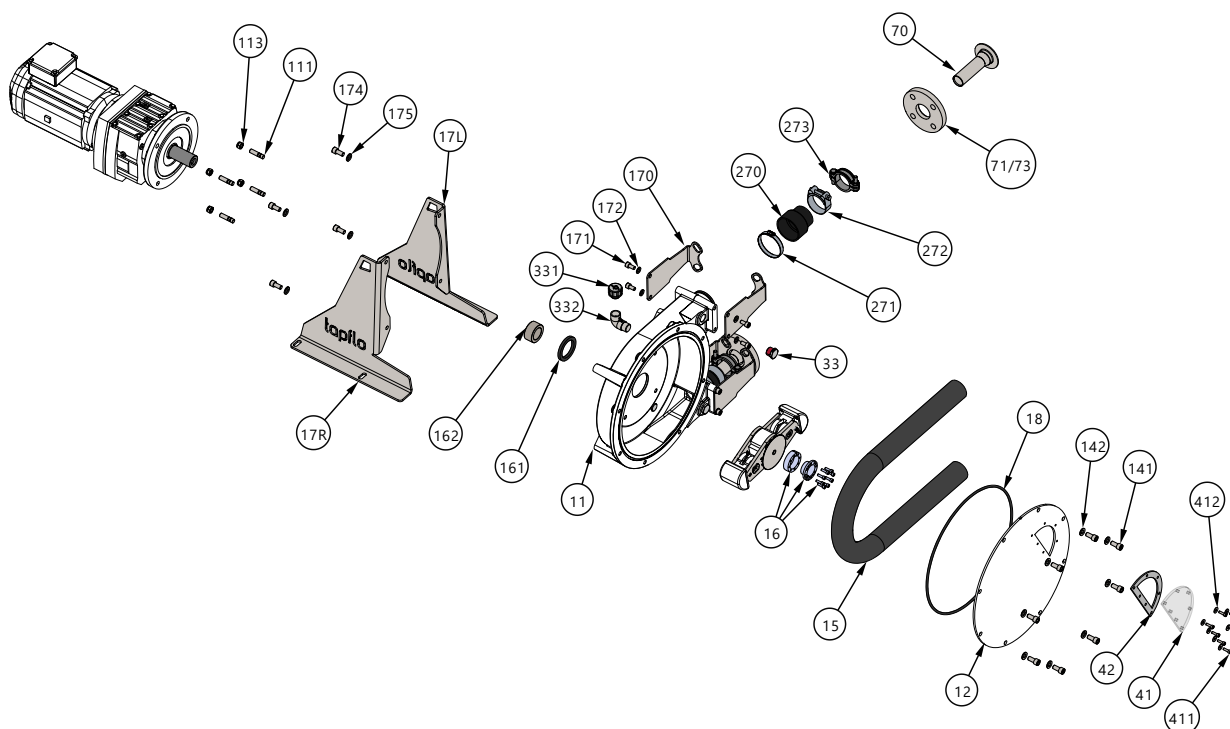

5.17. Spare parts list PTC38-40

Pos.	Q-ty	Description	Material
11	1	Pump casing	Nodular cast iron
111	4	Gearmotor mounting stud bolts	Zinck plated steel
113	4	Gearmotor mounting nuts	A4
12	1	Front cover	Galvanized steel
141	8	Front cover mounting bolt	A4-70
142	8	Front cover mounting washer	A4-70
15	1	Hose	NR, NBR, EPDM
161	1	Shaft seal	NBR, EPDM
162	1	Seal ring	1.7035 steel
165	1	Seal flange	Steel
17L	1	Pump foot - left	AISI 304L
17R	1	Pump foot - right	AISI 304L
170	4	Connection bracket	AISI 304L
171	8	Connection bracket bolt	A4-70
172	8	Connection bracket washer	A4-70
174	4	Casing mounting bolt	A4-70
175	4	Casing mounting washer	A4-70
18	1	Casing seal	EPDM, NBR
270	2	Boot cover	EPDM, NBR
271	2	Clamp band big - casing	AISI 304
272	2	Clamp band small – hose	AISI 316

5. SPARE PARTS

273	2	Clamp sleeve	Zinc plated steel
33	3	Drain plug – small	AISI 316L
331	1	Breather cap	PA/NBR/AISI304
332	1	Breather plug elbow	AISI 316L
41	1	Revision window	Polycarbonate
42	1	Revision window gasket	NBR
411	7	Revision window mounting bolt	A4-70
412	7	Revision window mounting washer	A4-70
70	2	Flange pipe / insert	AISI 316L, PP-H
71/73	2	Flange ring ANSI / DIN	AISI 316L

5.18. Exploded view rotor PTC38-40

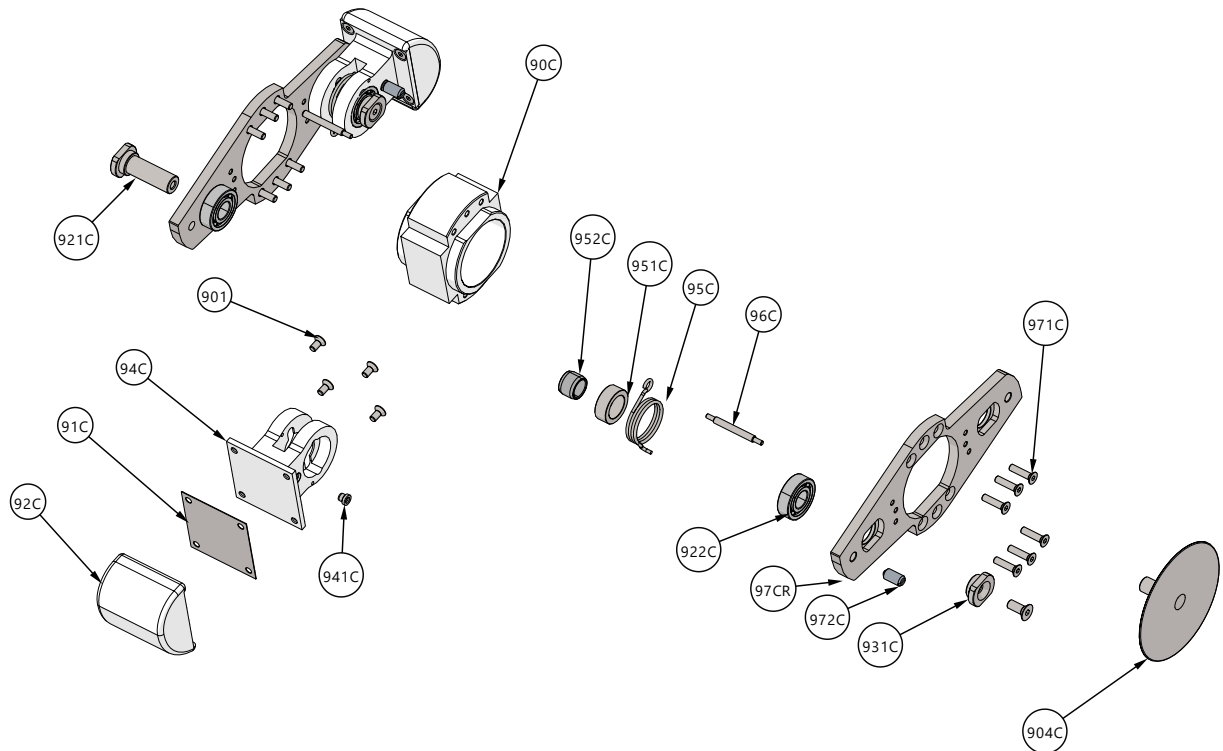

5.19. Spare parts list rotor PTC40

Pos.	Q-ty	Description	Material
90C	1	Rotor	
91C	2	Shim	
92C	2	Shoe	
94C	2	Shoe bracket	
95C	2	Shoe spring	
96C	2	Shoe spring pin	
97CR	1	Rotor plate rear	
901	8	Shoe screw	
904C	1	Rotor cap	
921C	2	Shoe pin	

5. SPARE PARTS

922C	4	Shoe bearing	
931C	2	Shoe pin washer	
941C	2	Guide bushing	
951C	2	Spring bushing	
952C	2	Spring bearing	
971C	12	Rotor plate screw	
972C	2	Ball spring plunger	

5.20. Stocking recommendation

Even at normal operation some elements in the pump will be worn. In order to avoid expensive breakdowns we recommend having a few spare parts in stock as a minimum:

Pos.	Description	Q-ty
15	Hose	2-3*
161	Shaft seal	1
18	Casing seal	1
42	Revision window gasket**	1
91	Shim**	8

* Depending on the application conditions it is recommended to keep 2 to 3 hoses on stock.

** Only for PT25-PT125.

What is more Tapflo offers **1 year spare parts KITS** for the PT pumps:

- For PT5 – PT20 pumps: **KIT PT5/10, KIT PT15, KIT PT20**

Pos.	Description	Q-ty
12	Front cover	1
16S	Complete clamping set (16+161+162)	1
18	Casing O-ring	2
270	Boot cover	4
271	Clamp band big – casing	4
272	Clamp band small - hose/boot cover	4
273	Clamp band small - hose/insert	4
274	Circlip	4

- For PT25 – PT60 pumps: **KIT PT25, KIT PT32/38, KIT PT40, KIT PT51, KIT PT60**

Pos.	Description	Q-ty
16S	Complete clamping set (16+161+162)	1
18	Casing O-ring	2
41	Revision window	2
42	Revision window gasket	2
91	Shim	2
270	Boot cover	4
271	Clamp band big – casing	4
272	Clamp band small - hose	4
273	2-piece hose clamp	4

5. SPARE PARTS

5.21. How to order parts

When ordering spare parts for Tapflo pumps, let us know what is the **model number** and **serial number**. Then just indicate the part numbers from the spare parts list and quantity of each item.

5.22. Pump code

The model number on the pump and on the front page of this instruction manual tells the pump size and materials of the pump.

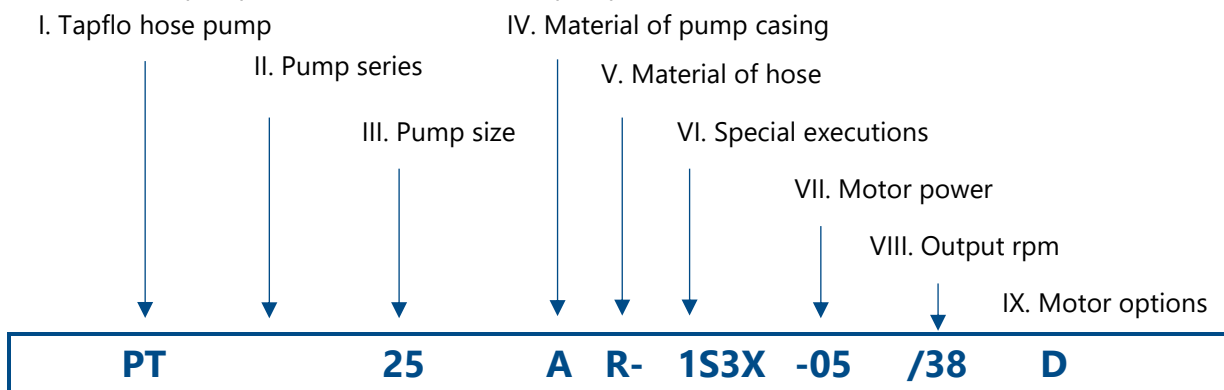

- I. PT = Tapflo hose pump
PXT = Tapflo ATEX hose pump
- II. Pump series:
blank = High pressure pump
D = Duplex pump – 2 pump heads with one gearmotor
- III. Pump size = Hose inner diameter*
*See section 5.23
- IV. Material of pump casing:
G = Nodular Cast Iron (standard)
- V. Material of hose:
E = EPDM
N = NBR (nitrile rubber)
R = NR (standard)
W = EPDM FDA
S = NR FDA
F = NBR FDA
C = CSM
- VI. Special executions:
1 = Optional in/outlet material
S = AISI 316L (standard)
T = PTFE
P = PE AST
L = PP
2 = Inlet/outlet direction (looking from pump head side)
L = Left
R = Right (standard)
U = Up
D = Down
3 = Optional connection type
A = ANSI/ASME B16.5 Class 150 Flange
- 5 = Other special executions
D = Switch for rotation direction change
F = Flat pack → pump head semi-assembled
H = Horizontal pump orientation
L = Hose leak detection system
MS = Gearmotor support frame
PF = Painted frame
R = Revolution counter
T = 3-lobe rotor (standard on PT5)
VA = Automatic vacuum system
VV = Venturi vacuum system
6 = Flange bracket options
blank = Galvanized steel
S = AISI 316L stainless steel
- VII. Motor power
01 = 0.18 kW 75 = 7.5 kW
02 = 0.25 kW 90 = 9.0 kW
03 = 0.37 kW 110 = 11 kW
05 = 0.55 kW 150 = 15 kW
07 = 0.75 kW 185 = 18.5 kW
11 = 1.1 kW 220 = 22 kW
15 = 1.5 kW 300 = 30 kW
22 = 2.2 kW 340 = 34 kW
30 = 3.0 kW
40 = 4.0 kW
55 = 5.5 kW
- VIII. Output rpm
- IX. Motor options
C = External cooling fan
D = Built on frequency inverter
A = Angle reducer

5. SPARE PARTS

B = BSP male thread

R = mechanical variator

C = SMS 3017 clamp

F = EN 1092-1 flange (standard on PT25-PT80)

H = Hose tail (standard on PT5-PT20)

T = DIN 32676 clamp

5.23. Obsolete codification

In 2023 PT hose pumps have undergone major rebranding, which affected pump size codification.

New code	PT5	PT10	PT15	PT20	PT25	PT32	PT38	PT40	PT51	PT60	PT65	PT80	PT80L	PT100	PT125
Obsolete code	PT5	PT10	PT15	PT20	PT25	PT32	PT40	PTX40	PT50	PT65	PTX65	PTX80	PT80	PT100	PT125

6. DATA

6. DATA

6.1. Capacity curves

The performance curves are based on water at 20°C. Other circumstances might change the performance. See below how the capacity will change at different viscosities and suction lifts. Intermittent duty = 1 hour stop for every 2 hours of operation. Occasional duty = not more than 1 hour per day.

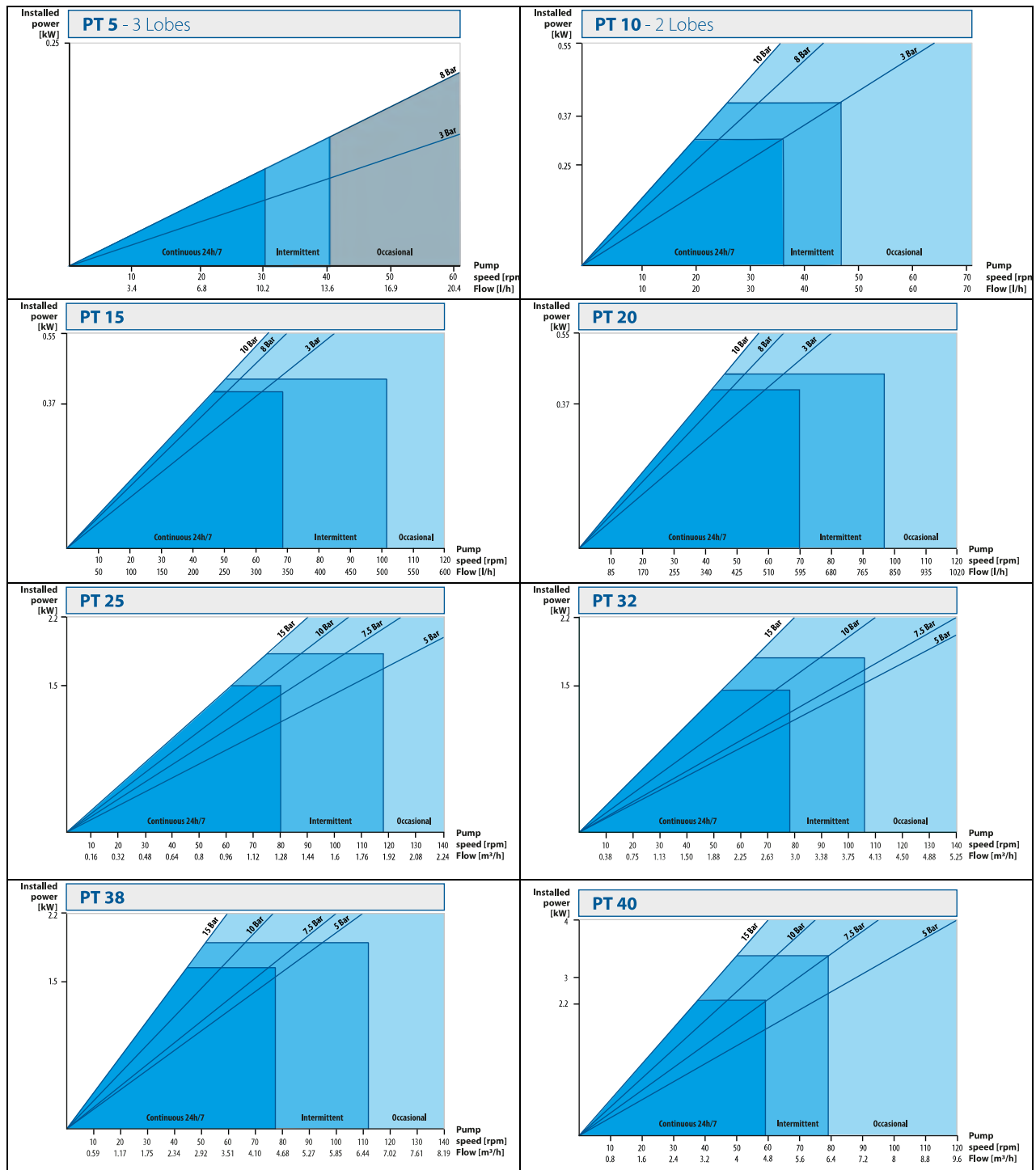

6. DATA

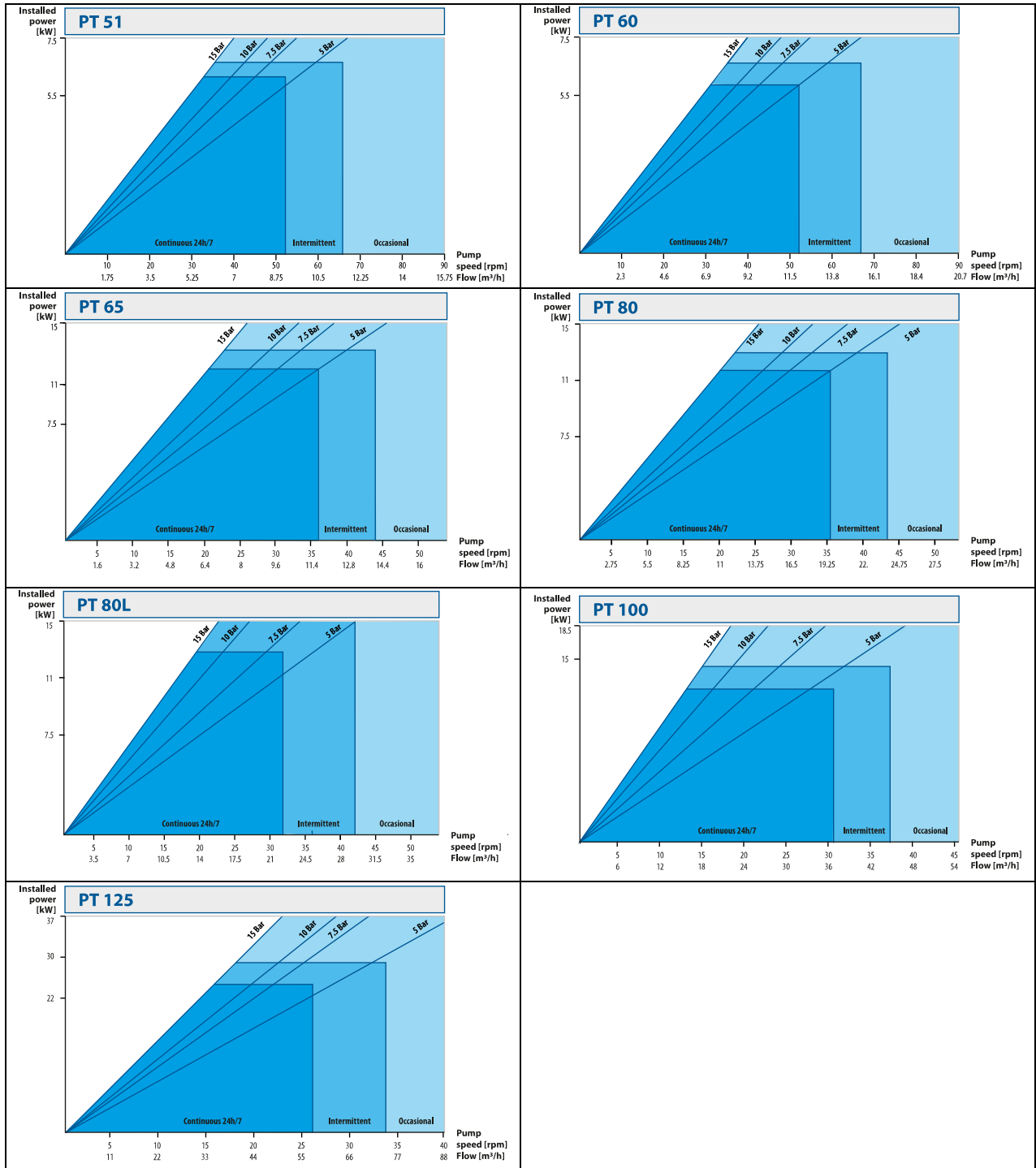

6. DATA

6.2. Technical data

TECHNICAL DATA	PUMP SIZE				
	PT5	PT10	PT15	PT20	PT25
Max capacity @ 50 Hz [l/h] / [US GPM]	7.7 / 0.03	92 / 0.4	305 / 1.34	518 / 2.28	967 / 4.26
Max discharge pressure** [bar] / [psi]	8 / 116	10 / 145	10 / 145	10 / 145	15 / 218
Max suction lift [m] / [Ft]	9 / 29.5	9 / 29.5	9 / 29.5	9 / 29.5	9 / 29.5
Maximum pump speed [rpm @ 50 Hz]	23	61	61	61	60
Max liquid temperature* [°C] / [°F]	80 / 176	80 / 176	80 / 176	80 / 176	80 / 176
Min ambient temperature [°C] / [°F]	-20 / -4	-20 / -4	-20 / -4	-20 / -4	-20 / -4
Max ambient temperature [°C] / [°F]	40 / 104	40 / 104	40 / 104	40 / 104	40 / 104
Weight with biggest gearmotor [kg] / [lb]	25 / 55	25 / 55.1	35 / 77	35 / 77.2	80 / 176.4
Lubricant volume [l] / [US Gallon]	0.2 / 0.05	0.2 / 0.05	0.55 / 0.15	0.55 / 0.15	2 / 0.53
Volume per revolution [ml] / [US oz]	6 / 0.2	25 / 0.85	83 / 2.8	141 / 4.77	269 / 9.1

TECHNICAL DATA	PUMP SIZE				
	PT32	PT38	PT40	PT51	PT60
Max capacity @ 50 Hz [m3/h] / [US GPM]	2.26 / 9.96	3.54 / 15.6	5.03 / 22.1	10.47 / 46.11	13.83 / 60.89
Max discharge pressure** [bar] / [psi]	15 / 218	15 / 218	15 / 218	15 / 218	15 / 218
Max suction lift dry [m] / [Ft]	9 / 29.5	9 / 29.5	9 / 29.5	9 / 29.5	9 / 29.5
Maximum pump speed [rpm @ 50 Hz]	61	61	63	60	60
Max liquid temperature* [°C] / [°F]	80 / 176	80 / 176	80 / 176	80 / 176	80 / 176
Weight with biggest gearmotor [kg] / [lb]	130 / 286.6	145 / 319.7	210 / 463	315 / 694.5	335 / 738.5
Lubricant volume [l] / [US Gallon]	3 / 0.8	3 / 0.8	6 / 1.6	13 / 3.4	13 / 3.4
Volume per revolution [l] / [US Gallon]	0.62 / 0.16	0.97 / 0.26	1.3 / 0.34	2.9 / 0.77	3.8 / 1

TECHNICAL DATA	PUMP SIZE				
	PT65	PT80	PT80L	PT100	PT125
Max capacity @ 50 Hz [m3/h] / [US GPM]	12.2 / 53.72	20.9 / 117.11	18.9 / 83.2	37.2 / 163.8	83 / 365.4
Max discharge pressure** [bar] / [psi]	15 / 218	15 / 218	15 / 218	15 / 218	15 / 218
Max suction lift dry [m] / [Ft]	9 / 29.5	9 / 29.5	9 / 29.5	9 / 29.5	9 / 29.5
Maximum pump speed [rpm @ 50 Hz]	38	38	38	31	38
Max liquid temperature* [°C] / [°F]	80 / 176	80 / 176	80 / 176	80 / 176	80 / 176
Weight with biggest gearmotor [kg] / [lb]	484 / 1067	700 / 1543.2	930 / 2050.3	1250 / 2755.8	1750 / 3858.1
Lubricant volume [l] / [US Gallon]	27 / 7.1	27 / 7.1	40 / 10.6	80 / 21.1	120 / 31.7
Volume per revolution [l] / [US Gallon]	5.4 / 1.43	9.1 / 2.4	11.7 / 3.1	20.6 / 5.44	36.4 / 9.62

* Max temperature can depend on hose material utilized in the pump.

** Max pressure is limited for certain rpm and motor power, see pump curve for specific limits.

6. DATA

6.3. Shimming tables

Only pump sizes PT25 – PT125 are equipped with shims. Refer to chapter 3.11. "Shoe shimming" for information about the shim adjustment procedure.

The amount of shims used under each shoe inside the pump depends on various factors like speed, pressure or liquid temperature. The below shimming guidelines will allow to increase the hose lifetime.

NOTE! If the pumped liquid is above 60 °C, remove one shim in comparison to the table below.

NOTE! If the pumped liquid viscosity is over 3.000 cP or the density is above 300 kg/m³, remove one shim in comparison to the table below.

NOTE! If the suction lift is higher than 4 mWC, add one shim in comparison to the table below.

NOTE! Both shoes must have the same amount of shims at all times.

Pressure [bar]	PUMP SIZE											No of shims
	PT25	PT32	PT38	PT40	PT51	PT60	PT65	PT80	PT80L	PT100	PT125	
	Speed [rpm]											
$\Delta P < 5$	0-40	0-45	0-40	0-40	0-30	0-30	0-25	0-25	0-20	0-15	0-10	0
	40-60	45-61	40-61	40-63	30-60	30-60	25-38	25-38	20-38	15-31	10-38	0
$5 \leq \Delta P < 7.5$	0-40	0-45	0-40	0-40	0-30	0-30	0-25	0-25	0-20	0-15	0-10	2
	40-60	45-61	40-61	40-63	30-55	30-55	25-38	25-38	20-38	15-31	10-32	1
$7.5 \leq \Delta P < 10$	0-40	0-45	0-40	0-40	0-30	0-30	0-25	0-25	0-20	0-15	0-10	3
	40-60	45-61	40-61	40-63	30-47	30-47	25-32	25-32	20-32	15-24	10-25	2
$10 \leq \Delta P \leq 15$	0-40	0-45	0-40	0-40	0-30	0-30	0-25	0-25	0-20	0-15	0-10	4
	40-60	45-61	40-61	40-63	30-38	30-38	25-26	25-26	20-26	15-20	10-20	3

ΔP = differential pressure

6.4. Dimensions

Dimensions in mm (where other is not indicated)

[Dimensions in inch \(where other is not indicated\)](#)

General dimensions only, ask us for detailed drawings. Changes reserved without notice.

6. DATA

6.4.1. PT5 – PT20

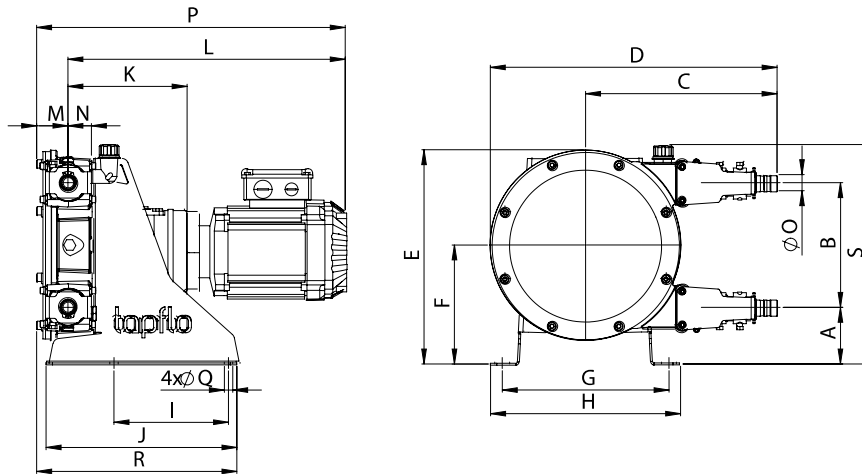

	PUMP SIZE			
	PT5	PT10	PT15	PT20
A	101	101	88	88
	3.98	3.98	3.46	3.46
B	115	115	193	193
	4.53	4.53	7.60	7.60
C	226	226	296	296
	8.90	8.90	11.65	11.65
D	324	324	443.5	443.5
	12.76	12.76	17.46	17.46
E	256	256	332	332
	10.08	10.08	13.07	13.07
F	158.5	158.5	184	184
	6.24	6.24	7.24	7.24
G	226.5	226.5	258	258
	8.92	8.92	10.16	10.16
H	254.5	254.5	294	294
	10.02	10.02	11.57	11.57
I	150	150	177	177
	5.91	5.91	6.97	6.97
J	265	265	282	282
	10.43	10.43	11.10	11.10
K	183.5	183.5	184	184
	7.22	7.22	7.24	7.24
L	396	428	429	429
	15.59	16.85	16.89	16.89
M	45	45	48	48
	1.77	1.77	1.89	1.89
N	34.5	34.5	36	36
	1.36	1.36	1.42	1.42
ØO	Ø16	Ø16	Ø20	Ø25
	0.63	0.63	0.79	0.98
P	441	473	477	477
	17.36	18.62	18.78	18.78
ØQ	4 x Ø10	4 x Ø10	4 x Ø13	4 x Ø13
	4 x 0.39	4 x 0.39	4 x 0.51	4 x 0.51
R	279.5	279.5	310	310
	11.00	11.00	12.20	12.20
S	274	274	340	340
	10.79	10.79	13.39	13.39

6. DATA

6.4.2. PT25 – PT80

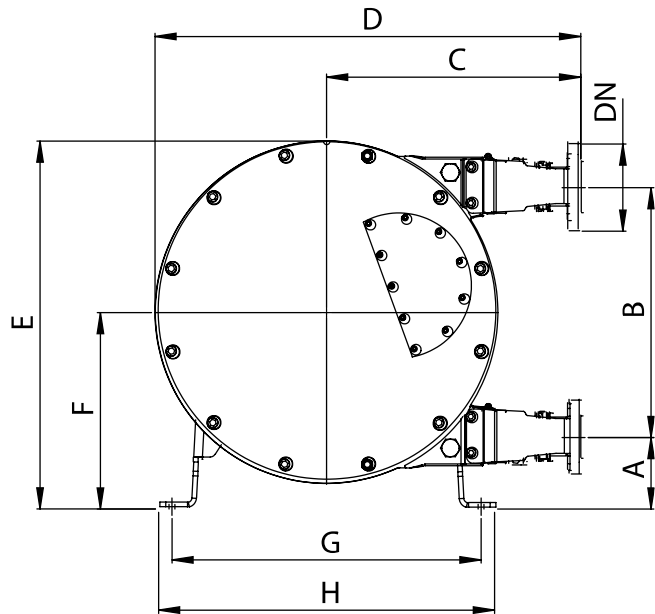
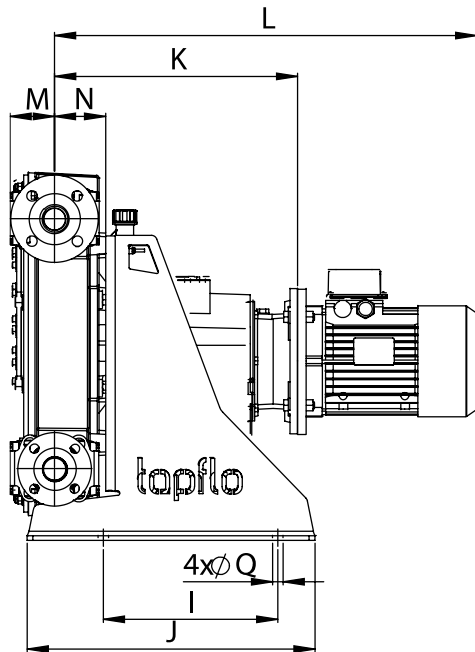

	PUMP SIZE							
	PT25	PT32	PT38	PT40	PT51	PT60	PT65	PT80
A	94	121	121	123	143	143	192	192
	3.7	4.76	4.76	4.84	5.63	5.63	7.56	7.56
B	262	330	330	430	554	554	746	746
	10.31	12.99	12.99	16.93	21.81	21.81	29.37	29.37
C	359	441	443	437	537	538	612	612
	14.13	17.36	17.44	17.20	21.14	21.18	24.09	24.09
D	549	682	684	732	899	900	1092	1092
	21.61	26.85	26.93	28.82	35.39	35.43	42.99	42.99
E	416	527	527	633	783	783	1045	1045
	16.38	20.75	20.75	24.92	30.83	30.83	41.14	41.14
F	225	286	286	338	420	420	565	565
	8.86	11.26	11.26	13.31	16.54	16.54	22.24	22.24
G	370	444	444	532	635	624	889	889
	14.57	17.48	17.48	20.94	25.00	24.57	35.00	35
H	404	488	488	578	701	689	955	955
	15.91	19.21	19.21	22.76	27.60	27.13	37.60	37.6
I	229	249	249	300	380	380	525.5	525.5
	9.02	9.8	9.8	11.81	14.96	14.96	20.69	20.69
J	390	425	425	495	580	580	785	785
	15.35	16.73	16.73	19.49	22.83	22.83	30.91	30.91
K	261	273	273	418	382	382	537.5	537.5
	10.28	10.75	10.75	16.46	15.04	15.04	21.16	21.16
L	616.5	621.5	621.5	726	805	805	1035	1035
	24.27	24.47	24.47	28.58	31.69	31.69	40.75	40.75
M	64.5	87	87	77	102	102	112	112
	2.54	3.43	3.43	3.03	4.02	4.02	4.41	4.41
N	69	88	88	88	100	100	137.5	137.5
	2.72	3.46	3.46	3.46	3.94	3.94	5.41	5.41
ØQ	4 x Ø13	4 x Ø13	4 x Ø13	4 x Ø18	4 x Ø20	4 x Ø20	4 x Ø24	4 x Ø24
	4 x 0.51	4 x 0.51	4 x 0.51	4 x 0.71	4 x 0.79	4 x 0.79	4 x 0.94	4 x 0.94
DN EN1092-1	DN25	DN32	DN40	DN40	DN50	DN65	DN65	DN80

6. DATA

6.4.3. PT80L – PT125

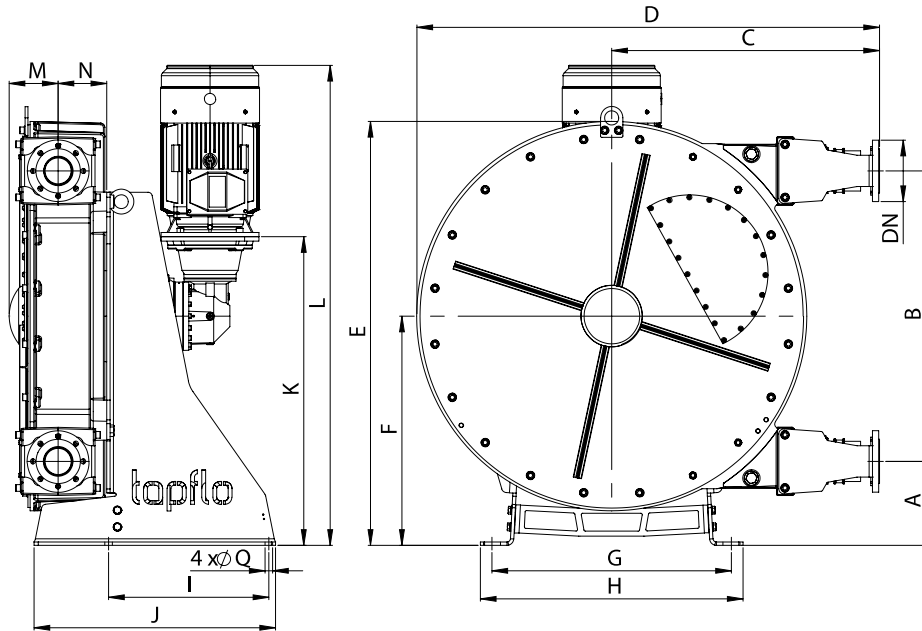

	PUMP SIZE		
	PT80L	PT100	PT125
A	241 9,49	300 11,81	260 10,24
B	876 34,49	1040 40,94	1273 50,12
C	806,5 31,75	958 37,72	1052 41,42
D	1372 54,02	1655 65,16	1875 73,82
E	1245 49,02	1517 59,72	1723,5 67,85
F	679 26,73	820 32,28	900 35,43
G	1058 41,65	857 33,74	979 38,54
H	1124 44,25	940 37,01	1063 41,85
I	569,5 22,42	573,5 22,58	763,5 30,06
J	840 33,07	864 34,02	1156 45,51
K	964 37,95	1105 43,50	1277 50,28
L	1506 59,29	1717 67,60	2017 79,41
M	144,5 5,69	175 6,89	285 11,22
N	146,5 5,77	174 6,85	235 9,25
ØQ	4 x Ø13 4 x 0,51	4 x Ø13 4 x 0,51	4 x Ø13 4 x 0,51
DN EN1092-1	DN25	DN32	DN40

6. DATA

6.5. Tightening torques

Checking of the tightening torques is necessary after all periods of stoppage, when temperature variations are a factor and after all transport and maintenance of the pump. What is more, for proper operation and safety the torque values should be checked frequently as part of preventive maintenance (contact Tapflo for interval proposals). Although pump applications vary, a general guideline is to re-torque the pump every two weeks.

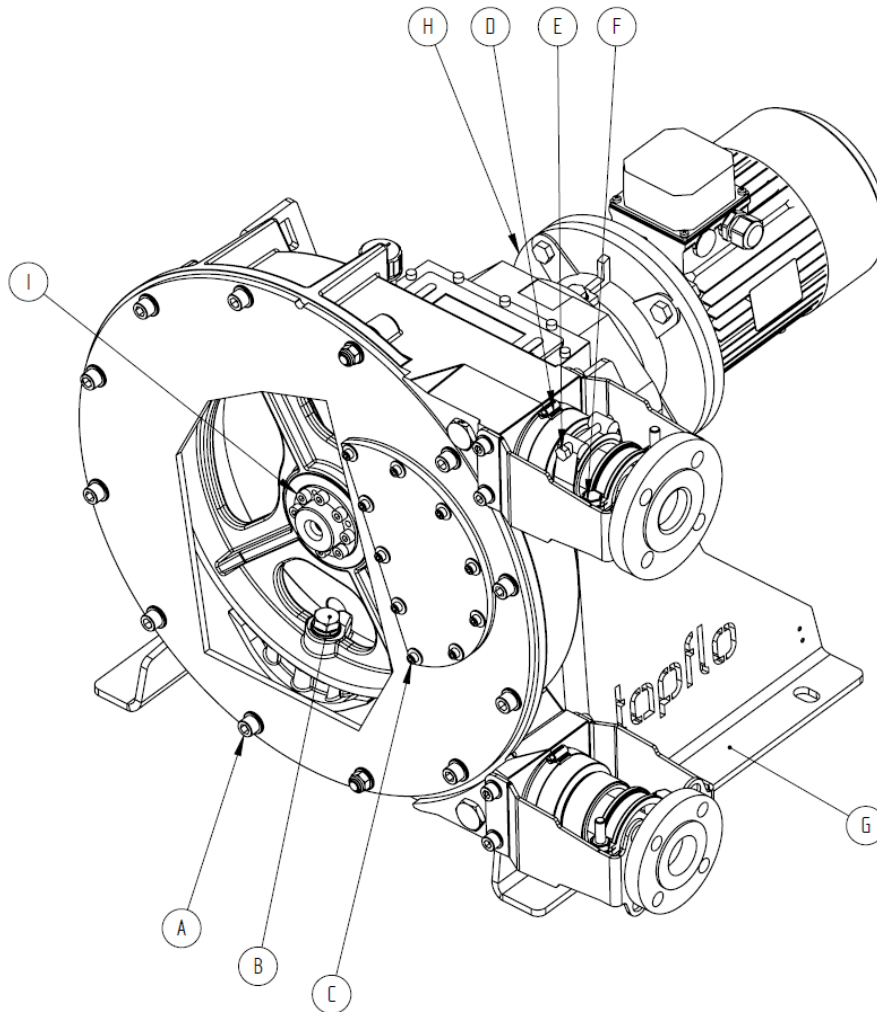

Item	Bolt pos.	Name	TORQUE [Nm]								
			PT5-20	PT25	PT32-38	PT40	PT51-60	PT65-80	PT80L	PT100	PT125
A	141	Front cover	3.3	15	27	27	65	65	65	127	127
B	901	Shoe	-	46	79	79	402	402	402	691	691
C	411	Revision window	-	3.3	3.3	3.3	3.3	3.3	3.3	3.3	3.3
D	271	Clamp band big (casing)	3	4	4	4	4	4	4	4	4
E	272	Clamp band small (hose)	12	16	30	30	30	30	45	45	45
F	273	2-piece hose clamp	10	20	50	50	50	50	50	50	50
G	174	Casing	8	15	27	27	65	127	127	220	220
H	113	Gearmotor	34	67	116	116	116	291	291	291	291
I	16	Clamping set	12	13	13	27	35	110	110	-	-

6. DATA

6.6. Permitted loads on manifolds

We recommend not to exceed the following loads and forces reacting on the manifolds.

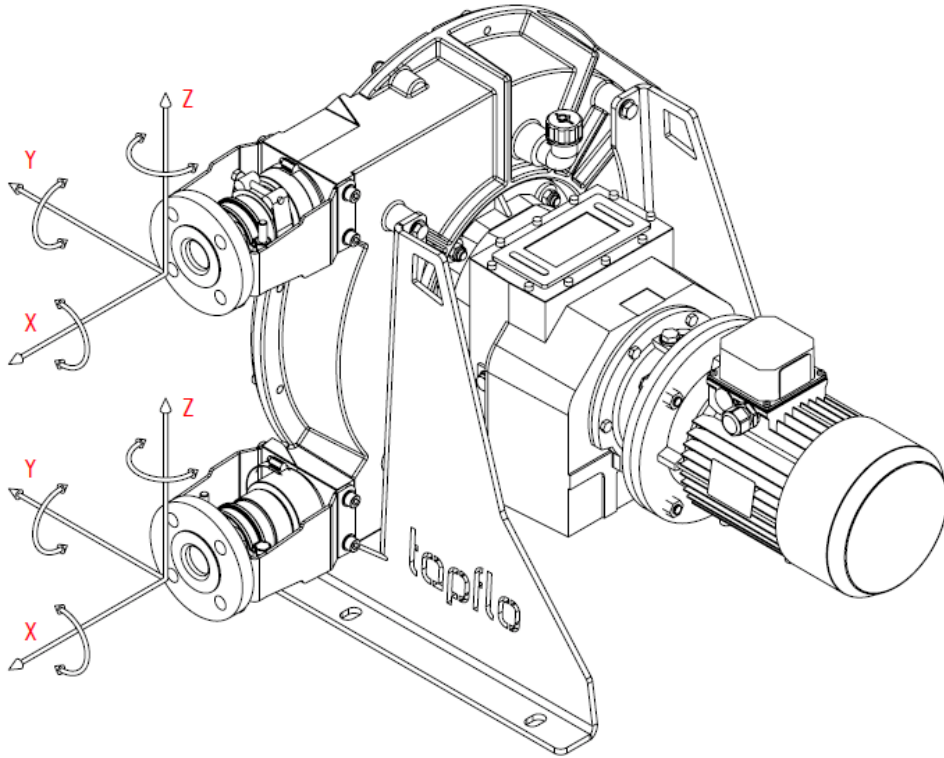

Pump size	Direction	Load [Nm]	Force [Nm]
PT5/PT10	X	90	20
	Y	60	30
	Z	20	20
PT15/PT20	X	150	10
	Y	50	10
	Z	30	5
PT25	X	130	20
	Y	70	30
	Z	50	10
PT32	X	280	50
	Y	100	50
	Z	150	20
PT38	X	340	125
	Y	100	85
	Z	150	20
PT40	X	290	20
	Y	110	30
	Z	90	20

Pump size	Direction	Load [Nm]	Force [Nm]
PT51/PT60	X	420	105
	Y	200	90
	Z	340	45
PT65/PT80	X	650	100
	Y	400	135
	Z	150	50
PT80L	X	1450	215
	Y	270	375
	Z	700	75
PT100	X	810	235
	Y	280	280
	Z	710	85
PT125	X	860	225
	Y	190	475
	Z	620	80

7. ATEX supplementary manual

7. ATEX supplementary manual

7.1. Potentially explosive atmospheres - ATEX

The standard PT series pumps are not allowed to operate in potentially explosive atmosphere. Special PXT pumps are available for such applications.

Follow this ATEX supplementary instructions and local/national rules for safe use.

ATEX (directive 2014/34/EU) classification of Tapflo PXT pumps:

II 2G Ex h IIB T4 Gb

II 2D Ex h IIIC T125°C Db

Equipment group: **II** – all other explosive areas than mines;

Category group: **2** – high level of protection (can be used in zone 1);

Atmosphere: **G** – gas;

D – dust;

Explosion group: **IIB** – gas group (such as ethylene);

IIIC – dust group (conductive dusts);

Type of protection: **h** – constructional safety;

Temperature class: **T4** – in the event of a malfunction, the maximum temperature of a surface that may be exposed to gas; **T4** = 135°C;

EPL protection level): **Gb, Db** – high protection level;

ATEX classification of complete unit depends on used drive.

Check if the ATEX marking of the delivered pump corresponds to the marking of the zone in which the pump will be installed.

The pumps are designed for particular applications. Do not use the pump on applications different from that for which it was sold without consulting us to ascertain its suitability.

7.2. Operating limits

Maximum operating parameters are selected for continuous operation, exceeding the limits may result in pump surface excessive temperature. It is forbidden to exceed these limits even for a short time during intermittent and occasional operation (described in section 6.1 "Capacity curves"), with intention of stopping the pump before reaching the temperature limits.

Pump model	PT5		PT10		PT15		PT20		PT25		PT32		PT38		PT40		
Motor power [kW]	0.25	0.25	0.37	0.55	0.37	0.55	0.37	0.55	1.5	2.2	1.5	2.2	1.5	2.2	2.2	3	4
Max output [rpm]	23	23	35	61	35	61	35	61	50	60	31	61	31	61	41	47	63
Max discharge pressure [bar]	8	10	10	10	10	10	10	10	15	15	15	15	15	15	15	15	15
Max inlet pressure [bar]	1																
Max liquid temperature [°C]	40																

7. ATEX supplementary manual

Pump model	PT51					PT60					PT65				PT80			
Motor power [kW]	5.5	7.5				5.5	7.5				7.5	11			7.5	11		
Max output speed [rpm]	26	38	47	55	60	26	38	47	55	60	20	20	32	38	20	20	32	38
Max discharge pressure [bar]	15	15	10	7.5	6	15	15	10	7.5	6	10	15	7.5	5	10	15	7.5	5
Max inlet pressure [bar]	1																	
Max liquid temperature [°C]	40																	

Pump model	PT80L	PT100	PT125				
Motor power [kW]	7.5	15	22	30	30	37	37
Max output speed [rpm]	20	24	20	25	32	32	38
Max discharge pressure [bar]	5	5	7.5	7.5	5	7.5	5
Max inlet pressure [bar]	1						
Max liquid temperature [°C]	40						

7.3. Construction materials use restrictions

Hose material

Only specific sizes and material executions of Tapflo hoses are allowed to operate in potentially explosive atmospheres or/and transfer flammable liquids.

Hose Material	PT5	PT10	PT15	PT20	PT25	PT32	PT38	PT40	PT51	PT60	PT65	PT80	PT80L	PT100	PT125
NR	X	X	F	F	F	F	F	F	F	F	F	F	F	F	F
NR (FDA)	X	X	X	X	X	X	X	X	NF	NF	NF	NF	NF	NF	NF
EPDM	X	X	F	F	F	F	F	F	F	F	F	F	F	F	X
EPDM (FDA)	X	X	X	X	X	X	X	X	X	X	X	X	X	X	X
NBR	X	X	NF	NF	NF	NF	NF	NF	NF	NF	NF	NF	NF	NF	NF
NBR (FDA)	X	X	X	X	NF	NF	NF	NF	NF	NF	X	NF	X	X	X
CSM	X	X	X	X	X	X	X	X	X	X	X	X	X	X	X

X – hose not allowed to operate in potentially explosive atmosphere;

NF – hose allowed to operate in potentially explosive atmosphere but not allowed to transfer flammable liquids;

F – hose allowed to operate in potentially explosive atmosphere and transfer flammable liquids - IIB T4.

Revision window and front cover material

The transparent polycarbonate front cover [12] (PT5-PT25) and revision window [41] (PT25-PT125) cannot be used. Only a metal window is allowed.

7. ATEX supplementary manual

7.4. Pumped liquids

Pumped liquid must be chemically compatible and not cause exothermic reaction with lubricant, nor with any of pump materials of construction.

The pumps are tested with water. If the pumped product can come into reaction with water, make sure the pump is dry before putting it into operation.

7.5. Installation, operation and maintenance

- The pump maintenance can be performed by the user.
- The personnel conducting pump servicing should be trained for working in potentially explosive environments and should wear antistatic workwear.
- The inspection of an explosion-proof pump should be carried out in accordance with the requirements of EN 60079-17 standard.
- The repair of an explosion-proof pump should be performed in compliance with the requirements of EN 60079-19 standard.

7.6. Spares

- Only original Tapflo spare parts can be used for spare parts replacement. Failing to follow the instruction voids the ATEX marking.
- When ordering spares ATEX execution must be clearly mentioned. Always indicate pump code and serial number.

7.7. Lubricant

- Specific hose lubricant volume is necessary for proper operation, lack of lubrication may result in pump surface excessive temperature.
- In ATEX pumps the required level is indicated by a sight glass [43] mounted on the pump cover. The correct glycerine level is in the middle of the sight glass. If the level rises, it may indicate a hose rupture. A drop in the level may indicate a leak.
- During a hose break it is mandatory to replace lubricant, see chapter 3.7. "*Casing emptying and lubricant filling procedure*" for more information.
- Use only Tapflo genuine lubricant
- When operating in negative temperatures, it is necessary to add antifreeze to the lubricant to prevent rotor block, resulting in motor overload. For more information refer to section 1.8.6. "*Temperature hazards*".

7.8. Hose leak detector

When pumping flammable liquids, a hose rupture can potentially create an explosive environment inside the pump casing. Even if there is no source of ignition, it is essential to stop the pump as soon as possible. For that purpose all Tapflo ATEX rated pumps are equipped with a leak sensor. The sensor must be connected to a circuit (e.g. via frequency inverter) that automatically stops the pump.

It is strongly recommended to establish preventive maintenance procedures, as outlined in chapter 3.9. *Hose replacement*.

7. ATEX supplementary manual

Description

Leak sensor is a 4-pin, normally open (NO) or normally open (NC) sensor using frequency sweep measuring principle.

ATEX marking: **II 1G Ex ia IIC T4 Ga**
II 1D Ex ta IIIC T100°C Da

The sensor detects solely liquids and solids with a dielectric constant of at least 1.5.

The sensor must be screwed into the designated location on the back of the pump casing. Sensor come pre-mounted in the pump's casing. When re-installing, apply the PTFE tape to the thread on the sensor, and then screw it in using a torque of maximum 30 Nm.

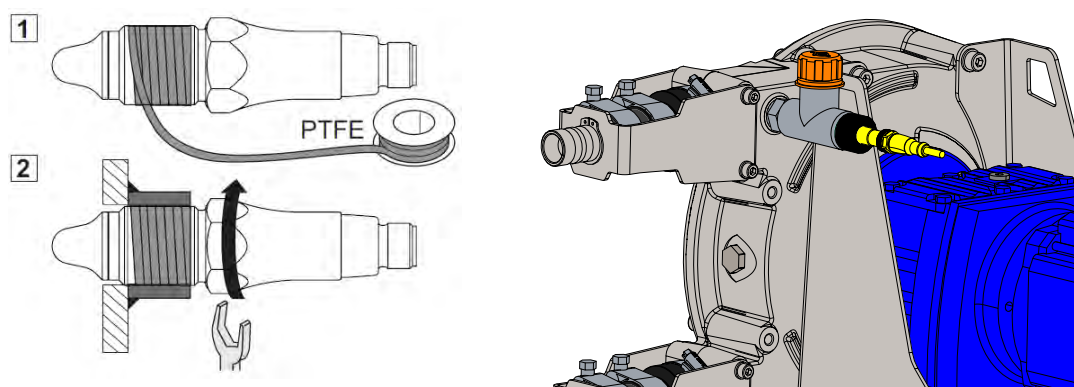

Electrical connection

- Provide a voltage supply of 12 V to 30 V DC
- Switch off supply voltage.
- Connect sensor in accordance with the pin assignment

Terminal assignment



Output type	Electrical circuit	Function	M12-A 4-pin	Cable outlet
PNP		+Vs	1	brown
		SW1 (NO)	4	black
		SW1 (NC)	2	white
		GND (0 V)	3	blue

Intrinsically safe "ia" electrical specification:

$U_i = 30V$ DC; $I_i = 100mA$; $P_i = 750mW$; $C_i = 43nF/m$; $L_i = 10\mu F/m$

The connection of temperature sensor in intrinsically safe execution "ia" must comply with the requirements of EN 60079-14 and EN 60079-25 standards.

7. ATEX supplementary manual

Cooperative instruments

Use "ia" isolation barriers for the connection, e.g. Baumber PROFSI3-B25100-ALG-LS.

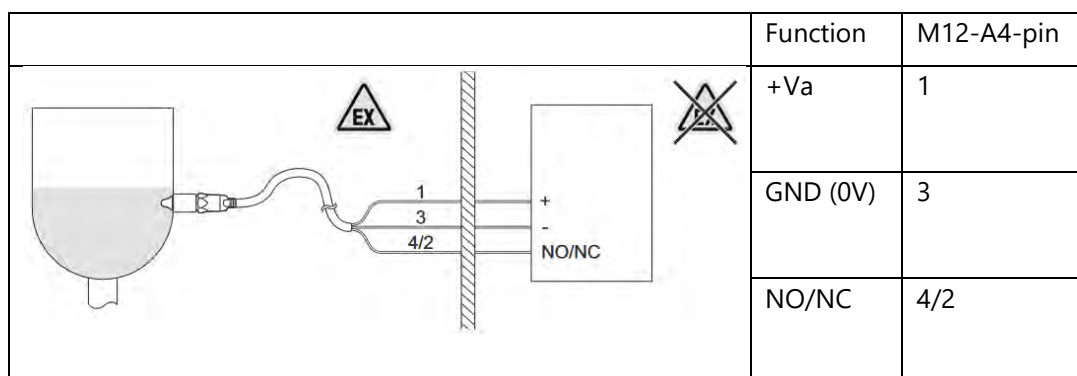

Use and maintenance

The sensor does not require any maintenance when connected according to specifications. In case of suspicion that sensor does not operate properly, unscrew the sensor from the pump and spray the tip with water.

Do not repair the sensor by yourself.

7.9. Temperature sensor

If the pump is used in accordance with this IOM manual and permissible operating conditions, it should not exceed the maximum temperature given by the pump's ATEX classification. However, each pump comes with a temperature sensor as an additional safety feature. The sensor must be connected to a circuit (e.g. via frequency inverter) that automatically stops the pump.

Description

Temperature sensor is a 3-wire PT100 resistance thermometer with 3m cable.

ATEX marking: **II 2G Ex ia IIC T4 Gb**
II 1D Ex ia IIIC T125°C Da

Mounting

The sensor must be placed in the designated location, fixed with M4 screw by its pass-through hole on the front of the pump front cover.

Connection of a 3-wire line

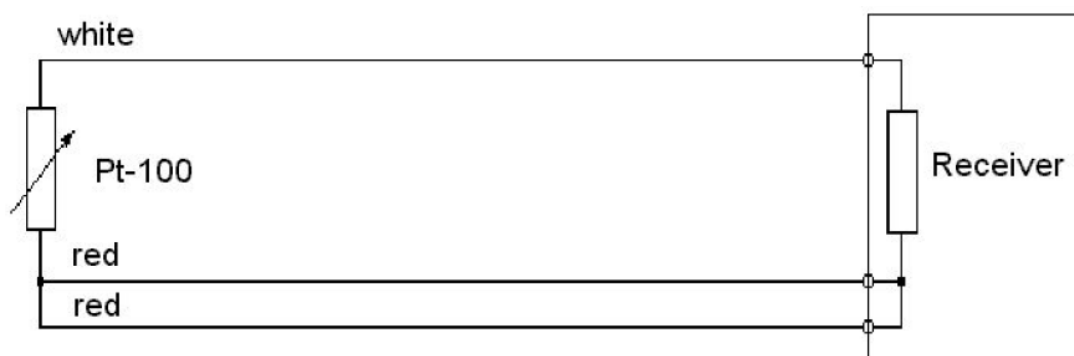

7. ATEX supplementary manual

Intrinsically safe "ia" electrical specification:

$U_i = 45V$, $I_i = 110mA$, $P_i = 750mW$, $C_i = 0,1nF/m$, $L_i = 1\mu F/m$

The connection of temperature sensor in intrinsically safe execution "ia" must comply with the requirements of EN 60079-14 and EN 60079-25 standards.

Cooperative instruments

The sensor can cooperate with any instruments adjusted to work with resistance thermometer.

Temperature threshold

The stop circuit activation temperature threshold for the PXT series is 90°C. The temperature threshold should take into account the measurement accuracy of the temperature reading device, e.g. to a accuracy of $\pm 2^\circ C$, temperature threshold must be set to $90^\circ C - 2^\circ C = 88^\circ C$.

Use and maintenance

The sensor does not require any maintenance when connected according to specifications. In case of suspicion that sensor does not operate properly, place it in known temperature, measure its resistance and compare the value with value included in EN 60751 and EN 60584 standards.

7. ATEX supplementary manual

7.10. Casing and front cover positions

When operating in potentially explosive atmospheres, pumps are allowed to operate in two positions, pump connections facing left or right. Directing casing up and down is forbidden.

Front cover position is determined by the direction of the pump casing. Therefore, after a pump maintenance or when changing the pump casing direction, it is important to also set the position of the front cover according to the guidelines in this section.

PXT pumps are assembled with casing directed right as standard configuration. However, when using the "2L" code pump can be delivered with casing assembled left as an optional configuration.

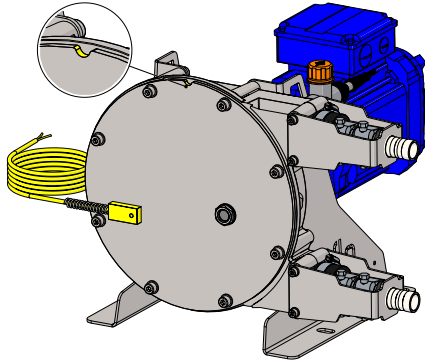
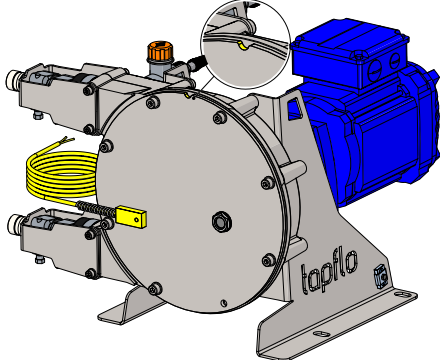
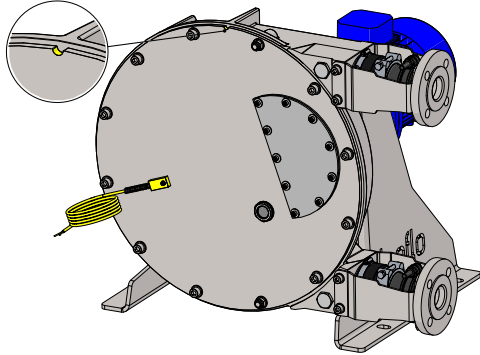
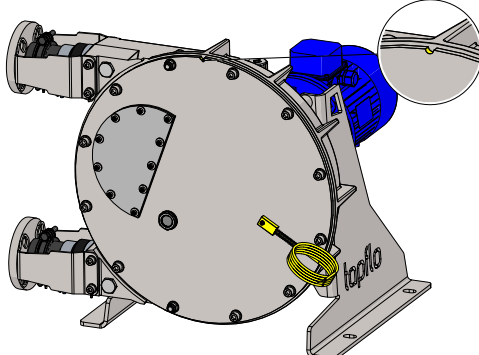
PT5-20	
When changing the direction of the pump casing, front cover maintains the same position. Undercut should be facing upwards.	
	
Fig. 7.10.1 Casing position right (standard)	Fig. 7.10.2 Casing position left (optional)
PT25-60	
When changing the direction of the pump casing, the front cover must be turned from front to back, ensuring that the undercut is facing upwards. Additionally, the revision window, sight glass, and temperature sensor need to be reassembled.	
	
Fig. 7.10.3 Casing position right (standard)	Fig. 7.10.4 Casing position left (optional)

7. ATEX supplementary manual

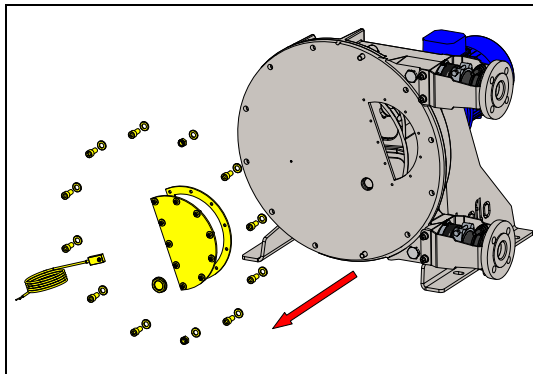

Fig. 7.10.5
Take out casing screws [141], washers [142], temperature sensor, revision window screws[411], revision window[41], revision window gasket [42], sight glass [43].

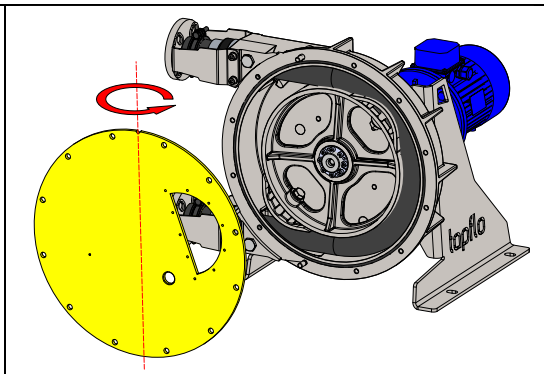

Fig. 7.10.6
Change casing direction and turn the front cover [12] front to back, and assemble all the items listed in **fig. 7.10.5**.

PT65-PT125

When changing the direction of the pump casing, the front cover must be turned by an angle, ensuring that the mounting holes for the lifting ring are facing upwards.

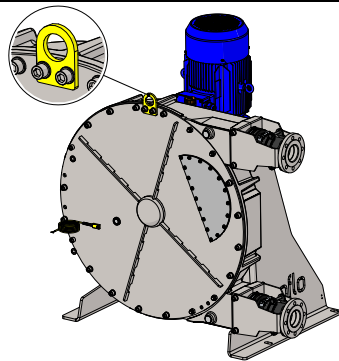

Fig. 7.10.7
Casing position right (standard)

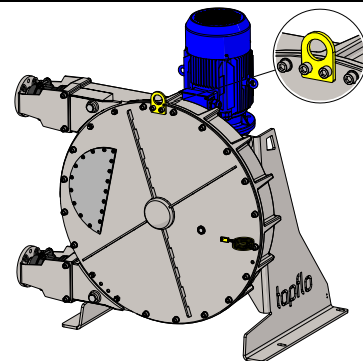

Fig. 7.10.8
Casing position left (optional)

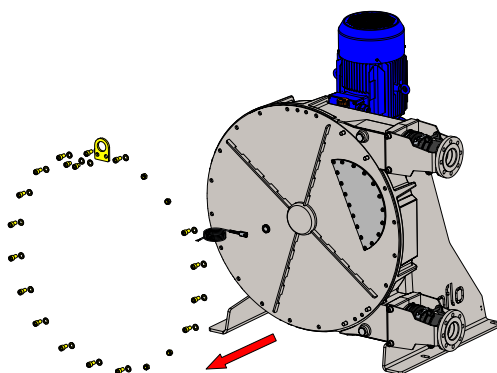

Fig. 7.10.9
Take out front cover bolts [141], washers [142], stud bolts [143], nuts [144]; lifting ring [13], bolts [131] and washers [132].

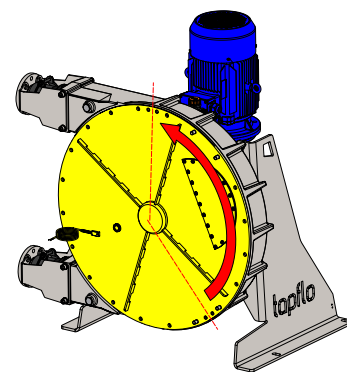

Fig. 7.10.10
Change casing direction and turn the front cover [12] by an angle so the lifting ring [13] mounting holes are facing upwards. Reassemble all items listed in **fig. 7.10.9**.

7. ATEX supplementary manual

7.11. Shoe shimming

Avoid shoe over shimming as it may generate increased temperature, follow the shimming procedure in section 3.11 "Shoe shimming" and see 6.3 "Shimming tables" for amount of shims for specific operating conditions.

7.12. Rotor assembly

Special attention should be paid to the position of the rotor in the pump housing, and its fixing by clamping set, as failure to maintain it, may result in pump damage and increased surface temperature, see section 3.12 "Rotor assembly" for detailed instruction.

7.13. Foreign objects in pump casing

- Foreign objects in pump casing may lead to increased surface temperature.
- Pay attention during pump maintenance not to leave any tool inside the casing.
- When experiencing hose break, clean the casing thoroughly to avoid leaving any restudies, see section 3.10. "Pump casing cleaning procedure".

7.14. Dry run

Running a pump without liquid may result in pump surface excessive temperature. Although it is allowed to dry run a pump, it is not considered as normal operation and pump should not run dry longer than 1 minute. If there is risk of longer dry run, appropriate dry run protection should be applied.

7.15. Closed-circuit operation

Closed-circuit operation with small volumes of pumped medium can lead to significant heating of the pumped medium.

In the case of closed-circuit operation, user must control the pumped medium temperature and provide a protective system against temperatures exceeding limits outlined in 7.2. "Operating limits".

7.16. High negative suction pressure

Running a pump with obstructed suction port, closed valve and high pressure losses generated by the installation, causes heavy strain on the pump hose and may result in pump surface excessive temperature. Refer to the safety measures listed in the table below before starting the pump.

Issue	Safety measure
Obstructed suction port	Check if the suction port is not obstructed
Closed suction valve	Check if the suction valve is fully opened
High pressure losses	Keep the suction line as short as possible and ensure that the piping diameter matches or exceeds the hose diameter. Pay attention for high viscosity fluids, as the higher the viscosity, the higher the pressure losses. Consult Tapflo for pressure losses calculation.

7. ATEX supplementary manual

7.17. Drive

- To ensure proper service of the drive, follow the guidelines provided in the original gearmotor's IOM manual supplied with the. The gearmotor model can be found on its nameplate.
- When reducing the motor rotation speed, it is important to monitor the surface temperature of the gear-motor and ensure that it does not exceed the nominal working temperatures specified by the gear-motor manufacturer. An optional external cooling system may be required.
- The pump can be supplied with or without a gearmotor. When coupling the pump head with a drive that was not supplied by Tapflo, it is important to follow the limits outlined in section 7.2. *Pump operating conditions*.
- When changing the drive, it is obligatory to check if the drive speed is within the limits of the pump allowable operating conditions.
- For proper gearmotor selection see separate appendix, the *PT flat pack manual appendix*.
- To maintain the pump head ATEX marking, gearmotor must have at least the same ATEX marking as pump head. PXT pumps are equipped with explosion-proof gearmotors that meet the following requirements:
 - II 2G Ex... IIB T4 Gb
 - II 2D Ex... IIIC T125°C Db

7.18. Earth connection of the pump and other equipment

Connect a suitable earth wire to the stainless steel earth connection that is placed on the pump stand. Connect the other end of the earth wire to earth and also make sure that other equipment like hoses/pipes/containers etc. are properly earthed/connected.

Required wire cross-section area $\geq 4\text{mm}^2$.

7.19. Antistatic surface

Pumps in ATEX execution should be cleaned in order to preserve antistatic properties. Layer of dust or other solid particles on the outer surfaces is unacceptable.

7.20. Paint thickness

In case of re-painting any of pump part, the thickness of the paint layer must not exceed 2mm.

7.21. Inspection

Check below points before every pump start or at least once a day when operating pump in continuous duty:

- Glycerine level
- Pump tightness
- If suction port is not obstructed (see section 7.16)
- If suction valve is fully opened (see section 7.16)
- Pump earthing connection

8. WARRANTY

8.2. Returning parts

When returning parts to Tapflo follow this procedure:

- Consult Tapflo for shipping instructions.
- Cleanse or neutralize and rinse the part/pump. Make sure the part/pump is completely empty from liquid.
- Pack the return articles carefully to prevent any damage during transportation.

Goods will not be accepted unless the above procedure has been complied with.

8.3. Warranty

Tapflo warrants products under conditions as stated below for a period of not more than 5 years from installation and not more than 6 years from date of manufacturing.

1. The following terms and conditions apply to the sale of machinery, components and related services and products, of Tapflo (hereinafter "the products").
2. Tapflo (the manufacturer) warrants that:
 - a. its products are free of defects in material, design and workmanship at the time of original purchase;
 - b. its products will function in accordance with Tapflo operative manuals; Tapflo does not guarantee that the product will meet the precise needs of the Customer, except for those purposes set out in any invitation to render documents or other documents specifically made available to Tapflo before entering into this agreement;
 - c. high quality materials are used in the construction of the pumps and that machining and assembly are carried out to the highest standards.

Except as expressly stated above, Tapflo makes no warranties, express or implied, concerning the products, including all warranties of fitness for a particular purpose.

3. This warranty shall not be applicable in circumstances other than defects in material, design, and workmanship. In particular warranty shall not cover the following:
 - a. Periodic checks, maintenance, repair and replacement of parts due to normal wear and tear (seals, O-rings, rubber items, hoses, etc.);
 - b. Damage to the product resulting from:
 - b.1. Tampering with, abuse or misuse, including but not limited to failure to use the product for its normal purposes as stated at the time of purchase or in accordance with Tapflo instructions for use and maintenance of the product, or the installation or improper ventilation or use of the product in a manner inconsistent with the technical or safety standard in force;
 - b.2. Repairs performed by non-skilled personnel or use of non-original Tapflo parts;
 - b.3. Accidents or any cause beyond the control of Tapflo, including but not limited to lightning, water, fire, earthquake, and public disturbances, etc.;

8. WARRANTY

4. The warrantee shall cover the replacement or repairing of any parts, which is documented faulty due to construction or assembling, with new or repaired parts free of charges delivered by Tapflo. Parts subjected to normal tear and wear shall not be covered by the warranty. Tapflo shall decide as to whether the defective or faulty part shall be replaced or repaired.
5. The warrantee of the products shall be valid for a period in accordance to the current law from the date of delivery, under the condition that notice of the alleged defect to the products or parts thereof be given to Tapflo in written within the mandatory term of 8 days from the discovery. Repair or replacement under the terms of this warranty shall not give a right to an extension to, or a new commencement of, the period of warranty.
6. Repair or replacement under the terms of this warranty shall not give a right to an extension to, or a new commencement of, the period of warranty. Repair or replacement under the terms of this warranty may be fulfilled with functionally equivalent reconditioned units. Tapflo qualified personnel shall be solely entitled to carry out repair or replacement of faulty parts after careful examination of the pump. Replaced faulty parts or components will become the property of Tapflo.
7. The products are built in accordance with standard CE normative and are tested (where applicable) by Tapflo. Approval and tests by other control authority are for the customer's account. The products shall not be considered defective in materials, design or workmanship if they need to be adapted, changed or adjusted to conform to national or local technical or safety standards in force in any country other than that for which the unit was originally designed and manufactured. This warranty shall not reimburse such adaptations, changes or adjustments, or attempt to do so, whether properly performed or not, nor any damage resulting from them, nor any adaptation, change or adjustments to upgrade the products from their normal purpose as described in the products operative manual without the prior written consent of Tapflo.
8. Installation, including electric and other connections to utility mains according to Tapflo drawings, is for the cost and responsibility of the customer, unless otherwise agreed in writing.
9. Tapflo will not be liable on any claim, whether in contract, tort, or otherwise, for any indirect, special, incidental, or consequential damages, caused to the customer or to third parties, including loss of profits, arising by any possible infringement of par. 3 above or by the customer or third parties being in the impossibility of using the products.

Steady the above, Tapflo liability to the customer or third parties from any claim, whether in contract, tort, or otherwise, shall be limited to the total amount paid by the customer for the product that caused the damages.

Sweden

Filaregatan 4 | S-442 34 Kungälv

Tel: +46 303 63390

Fax: +46 303 19916

E-mail addresses:

Commercial questions: sales@tapflo.com

Orders: order@tapflo.com

Tech support: support@tapflo.com

Tapflo products and services are available worldwide.

Tapflo is represented by own Tapflo Group Companies and carefully selected distributors assuring highest Tapflo service quality for our customers' convenience.

AUSTRALIA | AUSTRIA | AZERBAIJAN | BAHRAIN | BELARUS | BELGIUM | BOSNIA & HERZEGOVINA | BRAZIL | BULGARIA | CANADA | CHILE | CHINA | COLOMBIA | CROATIA | CZECH REPUBLIC | DENMARK | ECUADOR | EGYPT | ESTONIA | FINLAND | FRANCE | GEORGIA | GERMANY | GREECE | HONG-KONG | HUNGARY | ICELAND | INDIA | INDONESIA | IRELAND | ISRAEL | ITALY | JAPAN | JORDAN | KAZAKHSTAN | KUWAIT | LATVIA | LIBYA | LITHUANIA | MACEDONIA | MALAYSIA | MEXICO | MONTENEGRO | MOROCCO | NETHERLANDS | NEW ZEALAND | NORWAY | POLAND | PORTUGAL | PHILIPPINES | QATAR | ROMANIA | RUSSIA | SAUDI ARABIA | SERBIA | SINGAPORE | SLOVAKIA | SLOVENIA | SOUTH AFRICA | SOUTH KOREA | SPAIN | SWEDEN | SWITZERLAND | TAIWAN | THAILAND | TURKEY | UKRAINE | UNITED ARAB EMIRATES | UNITED KINGDOM | USA | UZBEKISTAN | VIETNAM

Tapflo Group Companies

Australia

Tapflo Oceania (Pty) Ltd
Tel: +61 1800 303 633
sales@tapflo.com.au

Austria

Tapflo Austria
Tel: +43 732 27292910
sales@tapflo.at

Baltic States

Tapflo Latvia
Tel: +371 67472205
sales@tapflo.lv

Belarus

Tapflo Belarus
Tel: +375 17 3934609
sales@tapflo.by

Belgium

Tapflo Benelux B.V.
Tel: +31 (0)85 00 743 00
info@tapflo.nl

Bulgaria

Tapflo EOOD
Tel: +359 (0)2 974 18 54
office@tapflo.bg

Canada

Tapflo Canada
Tel: +1 514 813 5754
canada@tapflo.com

Croatia

Tapflo d.o.o.
Tel: +385 91 4884 666
sales@tapflo.hr

Czech Republic

Tapflo s.r.o.
Tel: +420 513 033 924
tapflo@tapflo.cz

China

Tapflo (Wuxi)
Tel: +86 510 8241 7072
sales@tapflo.cn

Denmark

Tapflo Danmark
Tel: +45 36 454600
info@tapflo.dk

France

Tapflo France
Tel: +33 1 34 78 82 40
info@tapflo.fr

Hungary

Tapflo kft.
Tel: +36 30 148 8551
office@tapflo.hu

India

Tapflo Fluid Handling India Pvt Ltd
Tel: +91 20 65000215
ac@tapflo.in

Ireland

Tapflo Ireland Ltd
Tel: +353 1 2011911
info@tapflo.ie

Italy

Tapflo Italia
Tel: +39 0362307698
info@tapfloitalia.com

Japan

Tapflo Japan K.K.
Tel: +81-3-6240-3510
tapflojp@tapflo.co.jp

Kazakhstan

Tapflo Kazakhstan
Tel: +7 727 3278347
sales@tapflo.kz

Netherlands

Tapflo Benelux B.V.
Tel: +31 (0)85 00 743 00
info@tapflo.nl

Poland

Tapflo Sp. z o.o.
Tel: +48 58 530 42 12
info@tapflo.pl

Romania

S.C. Tapflo Rom. S.r.l.
Tel: +40 21 3451255
sales@tapflo.ro

Russia

Tapflo Company
Tel: +7 495 232 18 28
sales@tapflo.com.ru

Serbia

Tapflo d.o.o.
Tel: +381 21 44 58 08
sales@tapflo.rs

Slovakia

Tapflo s.r.o.
Tel: +421 911 137 883
tapflo@tapflo.sk

Slovenia

Tapflo GmbH
Tel: +386 68 613 474
sales@tapflo.hr

Spain

Tapflo Iberica
Tel: +34 91 8093182
avives@tapfloiberica.es

South Africa

Tapflo (Pty) Ltd
Tel: +27 31 701 5255
sales@tapflo.co.za

Turkey

Tapflo Makina Ltd
Tel: +90 216 467 33 11
sales@tapflo.com.tr

Ukraine

TOB Tapflo
Tel: +380 44 222 68 44
sales@tapflo.ua

Uzbekistan

Tapflo Uzbekistan
Tel: +998 712370940
sales@tapflo.uz

United Kingdom

Tapflo (UK) Ltd
Tel: +44 2380 252325
sales@tapflo pumps.co.uk



If your country is not listed
please visit
www.tapflo.com/en/contact