

# Use and Maintenance Manual

TRANSLATION OF THE ORIGINAL INSTRUCTIONS

MACHINERY

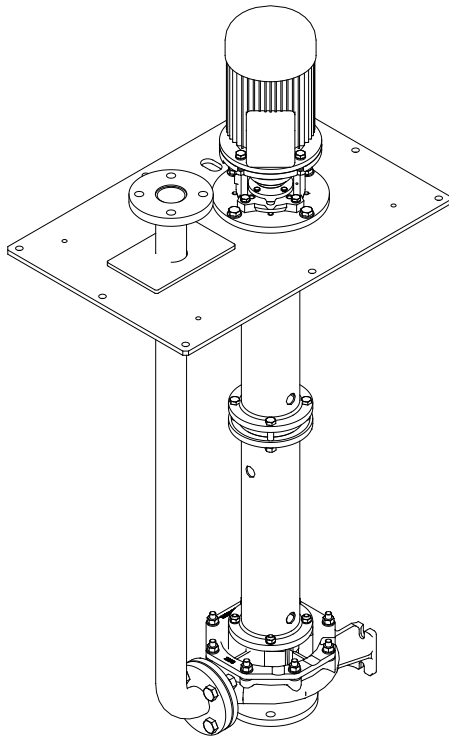

PARTLY COMPLETED MACHINERY

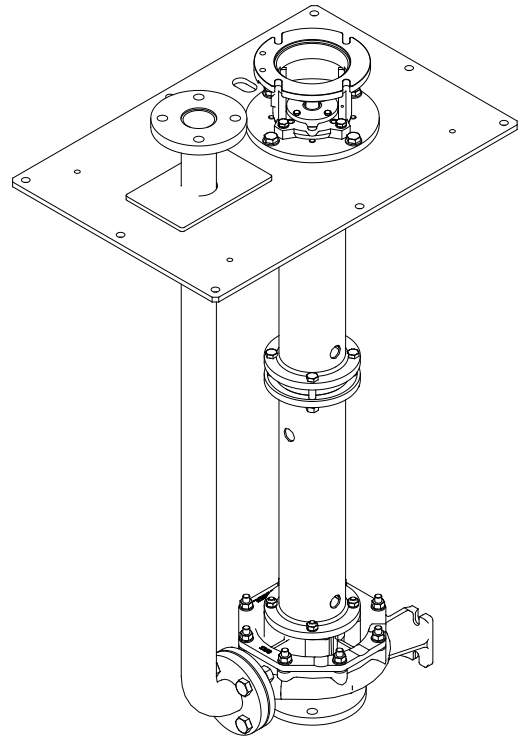

<b>MODEL</b>	<ul style="list-style-type: none"><li>• RDV - RGV - RBV - RCV - RNV - REV</li></ul>
<b>VERSION</b>	<ul style="list-style-type: none"><li>• VERTICAL PUMP</li></ul>
<b>EDITION</b>	<ul style="list-style-type: none"><li>• 01/2023</li></ul>

ENGLISH

## FOREWORD

All rights reserved. No part of this instruction manual can be reproduced or transmitted by any electronic or mechanical means, including photocopies, recordings or any other storage and data retrieval system, for any purpose other than the exclusive personal use of the purchaser, without the express written consent of Salvatore Robuschi & C. S.r.l.

Salvatore Robuschi & C. S.r.l. shall by no means be held responsible for the consequences resulting from the user's misuse of the system.

## EDITOR'S NOTE

This documentation is expressly addressed to technicians. Therefore, information that can be easily retrieved by reading these texts and analysing the drawings may not be explained further.

The Editor shall by no means be held responsible for the information and data referred to in this manual: all the information included in it is supplied, controlled and approved on the premises after Salvatore Robuschi & C. S.r.l./Representative's verification. Salvatore Robuschi & C. S.r.l. is in no way responsible for any consequences as a result of incorrect operations carried out by the user.

## GENERAL REMARKS

Any operational and maintenance instructions, as well as the recommendations described herein, shall be complied with.

To achieve the best results Salvatore Robuschi & C. S.r.l. recommends performing regular cleaning and maintenance operations to keep the plant in the best conditions. It is particularly important to train personnel in charge of the line, with regard to its use, maintenance and in compliance with the operating procedures and all the safety standards provided in this manual. In any case, note that the writing company is always available for any clarifications or additional information.

## REVISIONS INDEX

CODE	REV.	DATE	No. OF LAST PAGE	PUBLICATION NOTES
T-2362	04	09/2021	52	New Layout
T-2362	05	01/2023	54	Updating page 25 - Updating residual risks

AN UPDATED VERSION OF THIS MANUAL, TRANSLATED INTO VARIOUS LANGUAGES IS AVAILABLE IN DIGITAL FORM ON OUR WEBSITE "<http://www.salvatorerobuschi.com>".

## COPYRIGHT

© 2023 Salvatore Robuschi & C. S.r.l.

# 1. SUMMARY

<b>1. IDENTIFICATION.....</b>	<b>EN-7</b>
1.1. MANUFACTURER IDENTIFICATION .....	EN-7
1.2. IDENTIFICATION PLATE.....	EN-7
1.3. PUMP IDENTIFICATION CODE.....	EN-8
1.4. GROUP PARTITION.....	EN-10
<b>2. GENERAL INFORMATION .....</b>	<b>EN-11</b>
2.1. ADDRESSEES.....	EN-11
2.2. SUPPLY AND PRESERVATION .....	EN-11
2.3. USE AND KNOWLEDGE OF THE MANUAL.....	EN-11
2.4. SYMBOLS USED IN THE MANUAL.....	EN-11
2.5. DIRECTIVES OF REFERENCE.....	EN-12
2.6. WARRANTY.....	EN-12
2.7. TESTING .....	EN-12
2.8. DOCUMENTS SUPPLIED.....	EN-12
2.9. LIST OF DOCUMENTS AVAILABLE ONLINE.....	EN-12
<b>3. SAFETY RULES .....</b>	<b>EN-13</b>
3.1. PERSONAL PROTECTIVE EQUIPMENT .....	EN-13
3.2. RESIDUAL RISKS.....	EN-14
3.3. SAFETY REQUIREMENTS .....	EN-15
3.3.1. SAFETY INFORMATION FOR OPERATOR / USER (EXCLUDING INSTALLATION, MAINTENANCE AND DISASSEMBLY OPERATIONS).....	EN-15
3.4. NOISE.....	EN-16
3.5. VIBRATIONS.....	EN-16
<b>4. RECEIPT, HANDLING AND STORAGE.....</b>	<b>EN-19</b>
4.1. PACKAGING.....	EN-19
4.1.1. REMOVAL OF PACKAGING AND HANDLING.....	EN-19
4.2. CHECKING ON RECEIPT.....	EN-19
4.3. TRANSPORT AND HANDLING .....	EN-19
4.3.1. TRANSPORTATION OPERATIONS.....	EN-19
4.4. STORAGE .....	EN-25

<b>5. FEATURES.....</b>	<b>EN-26</b>
5.1. PERFORMANCE AND OPERATING LIMITS.....	EN-26
5.2. PERMITTED ENVIRONMENTAL CONDITIONS.....	EN-26
5.3. LIMITS FOR ATEX PUMPS.....	EN-26
<b>6. INSTALLATION .....</b>	<b>EN-27</b>
6.1. FOUNDATION .....	EN-27
6.2. INSTALLATION AND FIXING .....	EN-27
6.3. PIPES .....	EN-28
6.3.1. MAXIMUM PERMISSIBLE LOADS.....	EN-28
6.3.2. FIXING OF PIPES.....	EN-29
6.3.3. SUCTION AND DISCHARGE PIPES.....	EN-29
6.3.4. FILTERS.....	EN-29
6.3.5. VENT.....	EN-30
6.3.6. DRAIN.....	EN-30
6.3.7. CONTROL INSTRUMENTS.....	EN-30
6.3.8. LUBRICATION SYSTEMS .....	EN-31
6.4. MECHANICAL CHECKS AND PRELIMINARY CHECKS.....	EN-31
6.4.1. COUPLING GUARD.....	EN-31
6.4.2. ROTATION.....	EN-31
6.4.3. BEARING LUBRICATION - FIRST GREASING.....	EN-31
6.5. INSTALLATION OF PROTECTIONS.....	EN-32
6.6. ELECTRICAL CONNECTION .....	EN-32
<b>7. USE.....</b>	<b>EN-33</b>
7.1. PRELIMINARY INSPECTIONS.....	EN-33
7.2. START-UP .....	EN-33
7.3. CHECK THE MEDIUM LEVEL IN THE TANK .....	EN-34
7.4. LINES OF LUBRICATION FEEDING .....	EN-35
7.5. ROTATION DIRECTION TEST .....	EN-35
7.6. COUPLING ASSEMBLY .....	EN-35
7.7. PUMP START .....	EN-36
7.7.1. CHECKS AFTER START-UP .....	EN-36
7.8. STOP.....	EN-36
7.9. EXTENDED STOPS.....	EN-37

<b>8. CHECKS AND MAINTENANCE.....</b>	<b>EN-38</b>
8.1. SAFETY INFORMATION FOR CHECKS AND MAINTENANCE .....	EN-38
8.2. PERIODIC CHECKS.....	EN-39
8.2.1. LUBRICATION.....	EN-39
8.2.2. FLUSHING.....	EN-39
8.2.3. PERFORMANCE.....	EN-39
8.2.4. MOTOR .....	EN-39
8.2.5. PROTECTIONS .....	EN-39
8.2.6. MOUNTING CLEARANCE.....	EN-39
8.2.7. BEARING BUSHES.....	EN-41
8.2.8. MECHANICAL SEAL.....	EN-41
8.2.9. COLUMN LEVEL.....	EN-41
8.2.10. SUCTION STRAINER AND FILTERS.....	EN-42
8.2.11. INSTRUMENTATION AND AUXILIARY DEVICES.....	EN-42
<b>9. DISASSEMBLY AND REASSEMBLY .....</b>	<b>EN-43</b>
9.1. SAFETY INFORMATION FOR DISASSEMBLY AND REASSEMBLY .....	EN-43
9.2. PRELIMINARY OPERATIONS.....	EN-44
9.2.1. DISCONNECTION.....	EN-44
9.2.2. DRAIN AND RECLAMATION.....	EN-44
9.2.3. FINAL RECLAMATION.....	EN-44
9.3. INSTRUCTIONS FOR DISASSEMBLY AND REASSEMBLY OF THE PUMP .....	EN-45
<b>10. SPARE PARTS.....</b>	<b>EN-46</b>
10.1. SPARE PARTS REQUEST, COMMISSIONING AND START-UP.....	EN-46
10.2. SPARE PARTS AND SPARE PARTS SET FOR THE FIRST TWO YEARS OF USE (DIN 24296).....	EN-46
10.3. START UP SPARE PARTS AND SPARE PARTS SET.....	EN-47
<b>11. SHIPPING TO SUPPLIER .....</b>	<b>EN-48</b>
<b>12. END OF LIFE AND DISPOSAL.....</b>	<b>EN-49</b>
<b>13. APPENDIX A – AUXILIARY CONNECTIONS AND SEAL FLUSHING .....</b>	<b>EN-49</b>
13.1. SEAL EXECUTION IDENTIFICATION.....	EN-49
13.2. NAME .....	EN-49
13.3. AUXILIARY CONNECTIONS AND BUSHES/SEAL FLUSHING .....	EN-50

**14. APPENDIX B .....EN-52**

**15. APPENDIX C .....EN-53**

15.1. ADDENDUM FOR PARTLY COMPLETED MACHINERY ACCORDING TO  
DIRECTIVE 2006/42/EC ..... EN-53

15.1.1. CONNECTION TO A MOTOR PART BY FLEXIBLE COUPLING.....EN-53

15.1.2. CONNECTION TO A MOTOR PART THROUGH A DIFFERENT TYPE OF COUPLING.....EN-53

15.1.3. CONNECTION TO A MOTOR PART OF OPERATING PUMPS CERTIFIED FOR OPERATION IN AREAS  
SUBJECT TO ATEX DIRECTIVE 2014/34/EU.....EN-54

15.1.4. ANALYSIS OF RISKS RELATED TO COUPLING WITH A MOTOR PART .....EN-54

15.2. DECLARATION OF INCORPORATION..... EN-54

# 1. IDENTIFICATION

## 1.1. MANUFACTURER IDENTIFICATION

<b>Manufacturer</b>	<b>SALVATORE ROBUSCHI &amp; C. S.R.L.</b> Via Segrè 11/a - 43122 Parma - Italy tel. +39 0521 606285 Fax +39 0521 606278 www.salvatorerobuschi.com sr@salvatorerobuschi.com
---------------------	---

## 1.2. IDENTIFICATION PLATE

POS.	DESCRIPTION
1	MANUFACTURER'S LOGO
2	PUMP IDENTIFICATION CODE (See Paragraph "PUMP IDENTIFICATION CODE")
3	SERIAL NUMBER
4	PUMP DUTY FLOW RATE (IF SUPPLIED BY THE CUSTOMER)
5	'EX' MARKING (OPTIONAL – ONLY FOR PUMPS SUITABLE FOR OPERATING IN EXPLOSION HAZARD ZONES)
6	'CE' MARKING
7	YEAR OF MANUFACTURE
8	PUMP DUTY HEAD (IF SUPPLIED BY THE CUSTOMER)
9	CUSTOMER IDENTIFICATION ITEM (IF SUPPLIED BY THE CUSTOMER)
10	'ATEX' IDENTIFICATION MARKING (OPTIONAL – ONLY FOR PUMPS SUITABLE FOR OPERATING IN EXPOSITION HAZARD ZONES)
11	SPACE FOR ADDITIONAL NORMATIVE INFORMATION UPON CUSTOMERS' REQUEST

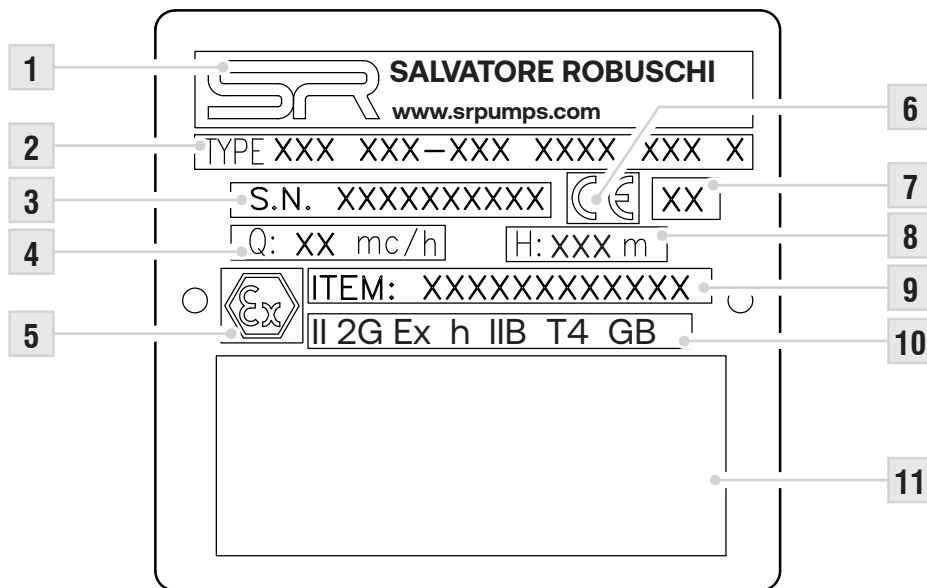

ENGLISH



**CAUTION!**  
**IT IS STRICTLY PROHIBITED** to remove the CE identification plate and/or replace it with other plates.  
 Should the plate be damaged, detached or removed for accidental reasons, the customer must inform the Manufacturer.

### 1.3. PUMP IDENTIFICATION CODE

There is an identification code on every pump.

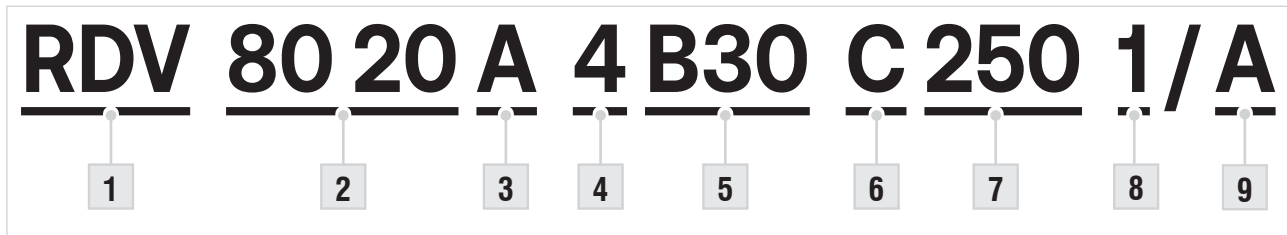

Below is the diagram of the coding applied:

POS.	DESCRIPTION																																																																												
1	<b>PUMP MODEL</b> <ul style="list-style-type: none"> <li>RDV – Vertical Pump – Closed Impeller</li> <li>RGV – Vertical Pump – Open Impeller</li> <li>RCV – Vertical Pump – Vortex Impeller</li> <li>RBV – Vertical Pump – Channel Impeller</li> <li>RNV – Vertical Pump – Closed Impeller</li> <li>REV – Vertical Pump – Open Channel Impeller</li> </ul>																																																																												
2	<b>PUMP SIZE</b>																																																																												
3	<b>IMPELLER REDUCTION</b> <ul style="list-style-type: none"> <li>“A” maximum diameter</li> <li>“B” 1° reduction</li> <li>“C” 2° reduction</li> <li>“AR” intermediate reduction (between A and B)</li> </ul>																																																																												
4	<b>MOTOR POLARITY</b> <ul style="list-style-type: none"> <li>0000 = Partly completed machinery</li> <li>2 = 2-pole electric motor</li> <li>4 = 4-pole electric motor</li> <li>6 = 6-pole electric motor</li> <li>8 = 8-pole electric motor</li> </ul>																																																																												
5	<b>ELECTRICAL MOTOR POWER</b> <ul style="list-style-type: none"> <li>0000 = Partly completed machinery</li> <li> <table border="1"> <thead> <tr> <th>KW</th> <th>0.25</th> <th>0.37</th> <th>0.55</th> <th>0.75</th> </tr> </thead> <tbody> <tr> <td>A - 0.25 → 0,75 kW</td> <td>Code</td> <td>A25</td> <td>A37</td> <td>A55</td> <td>A75</td> </tr> </tbody> </table> </li> <li> <table border="1"> <thead> <tr> <th>KW</th> <th>1.1</th> <th>1.5</th> <th>2.2</th> <th>3.0</th> <th>4.0</th> <th>5.5</th> <th>7.5</th> <th>9.2</th> </tr> </thead> <tbody> <tr> <td>B - 1.1 → 9.2 kW</td> <td>Code</td> <td>B11</td> <td>B15</td> <td>B22</td> <td>B30</td> <td>B40</td> <td>B55</td> <td>B75</td> <td>B92</td> </tr> </tbody> </table> </li> <li> <table border="1"> <thead> <tr> <th>KW</th> <th>11</th> <th>15</th> <th>18.5</th> <th>22</th> <th>30</th> <th>37</th> <th>45</th> <th>55</th> <th>75</th> <th>90</th> </tr> </thead> <tbody> <tr> <td>C - 11 → 90 kW</td> <td>Code</td> <td>C11</td> <td>C15</td> <td>C18</td> <td>C22</td> <td>C30</td> <td>C37</td> <td>C45</td> <td>C55</td> <td>C75</td> <td>C90</td> </tr> </tbody> </table> </li> <li> <table border="1"> <thead> <tr> <th>KW</th> <th>110</th> <th>132</th> <th>160</th> <th>200</th> <th>225</th> <th>250</th> <th>280</th> <th>315</th> <th>355</th> <th>400</th> </tr> </thead> <tbody> <tr> <td>D - 110 → 400 kW</td> <td>Code</td> <td>D11</td> <td>D13</td> <td>D16</td> <td>D20</td> <td>D22</td> <td>D25</td> <td>D28</td> <td>D31</td> <td>D35</td> <td>D40</td> </tr> </tbody> </table> </li> </ul>	KW	0.25	0.37	0.55	0.75	A - 0.25 → 0,75 kW	Code	A25	A37	A55	A75	KW	1.1	1.5	2.2	3.0	4.0	5.5	7.5	9.2	B - 1.1 → 9.2 kW	Code	B11	B15	B22	B30	B40	B55	B75	B92	KW	11	15	18.5	22	30	37	45	55	75	90	C - 11 → 90 kW	Code	C11	C15	C18	C22	C30	C37	C45	C55	C75	C90	KW	110	132	160	200	225	250	280	315	355	400	D - 110 → 400 kW	Code	D11	D13	D16	D20	D22	D25	D28	D31	D35	D40
KW	0.25	0.37	0.55	0.75																																																																									
A - 0.25 → 0,75 kW	Code	A25	A37	A55	A75																																																																								
KW	1.1	1.5	2.2	3.0	4.0	5.5	7.5	9.2																																																																					
B - 1.1 → 9.2 kW	Code	B11	B15	B22	B30	B40	B55	B75	B92																																																																				
KW	11	15	18.5	22	30	37	45	55	75	90																																																																			
C - 11 → 90 kW	Code	C11	C15	C18	C22	C30	C37	C45	C55	C75	C90																																																																		
KW	110	132	160	200	225	250	280	315	355	400																																																																			
D - 110 → 400 kW	Code	D11	D13	D16	D20	D22	D25	D28	D31	D35	D40																																																																		

POS.	DESCRIPTION																																																																	
6	<p><b>EXECUTION TYPE</b></p> <ul style="list-style-type: none"> <li>A Bottom bearing bush lubricated by pumped medium. Intermediate bearing bushes lubricated by discharge pipe through process medium.</li> <li>B Bearing bushes lubricated by a dedicated line, externally fed.</li> <li>E Bearing bushes lubricated by the medium in the column. Mechanical seal lubricated both by medium in the column and pumped medium.</li> </ul>																																																																	
7	<p><b>PUMP LENGTH [cm]</b></p> <ul style="list-style-type: none"> <li>080 = 80 cm</li> <li>100 = 100 cm</li> </ul> <p>Pump's total length has a tolerance <math>\pm 2,5</math> cm.</p>																																																																	
8	<p><b>PUMP'S MAIN MATERIALS CODE</b></p> <ul style="list-style-type: none"> <li>Refer to the table below.</li> </ul>																																																																	
<table border="1"> <thead> <tr> <th rowspan="2">DESCRIPTION</th> <th colspan="5">PUMP MATERIAL CODE</th> </tr> <tr> <th>0</th> <th>1</th> <th>2</th> <th>3</th> <th>S</th> </tr> </thead> <tbody> <tr> <td>CASING</td> <td>GJL 250</td> <td>GJL 250</td> <td>GJL 250</td> <td>CF8M (AISI 316)</td> <td>ON DEMAND</td> </tr> <tr> <td>CASING COVER</td> <td>GJL 250</td> <td>GJL 250</td> <td>GJL 250</td> <td>CF8M (AISI 316)</td> <td>ON DEMAND</td> </tr> <tr> <td>IMPELLER</td> <td>CF8M (AISI 316)</td> <td>GJL250/GJS400</td> <td>CF8M (AISI 316)</td> <td>CF8M (AISI 316)</td> <td>ON DEMAND</td> </tr> <tr> <td>SHAFT</td> <td>C45</td> <td>C45</td> <td>AISI 316</td> <td>AISI 316</td> <td>ON DEMAND</td> </tr> <tr> <td>SHAFT SLEEVE</td> <td>AISI 316L</td> <td>AISI 420</td> <td>AISI 316L</td> <td>AISI 316L</td> <td>ON DEMAND</td> </tr> <tr> <td>LANTERN</td> <td>GJL200/GJL250/S 235 JR</td> <td>GJL200/GJL250/S 235 JR</td> <td>GJL200/GJL250/S 235 JR</td> <td>GJL200/GJL250/S 235 JR</td> <td>GJL200/GJL250/S 235 JR</td> </tr> <tr> <td>IMPELLER HUB</td> <td>AISI 316L</td> <td>AISI 316L</td> <td>AISI 316L</td> <td>AISI 316L</td> <td>ON DEMAND</td> </tr> <tr> <td>WEAR RING <sup>(A)</sup></td> <td>AISI 316L</td> <td>AISI 316L</td> <td>AISI 316L</td> <td>AISI 316L</td> <td>ON DEMAND</td> </tr> <tr> <td>WEAR PLATE <sup>(B)</sup></td> <td>AISI 316L</td> <td>AISI 316L</td> <td>AISI 316L</td> <td>AISI 316L</td> <td>ON DEMAND</td> </tr> </tbody> </table>		DESCRIPTION	PUMP MATERIAL CODE					0	1	2	3	S	CASING	GJL 250	GJL 250	GJL 250	CF8M (AISI 316)	ON DEMAND	CASING COVER	GJL 250	GJL 250	GJL 250	CF8M (AISI 316)	ON DEMAND	IMPELLER	CF8M (AISI 316)	GJL250/GJS400	CF8M (AISI 316)	CF8M (AISI 316)	ON DEMAND	SHAFT	C45	C45	AISI 316	AISI 316	ON DEMAND	SHAFT SLEEVE	AISI 316L	AISI 420	AISI 316L	AISI 316L	ON DEMAND	LANTERN	GJL200/GJL250/S 235 JR	GJL200/GJL250/S 235 JR	GJL200/GJL250/S 235 JR	GJL200/GJL250/S 235 JR	GJL200/GJL250/S 235 JR	IMPELLER HUB	AISI 316L	AISI 316L	AISI 316L	AISI 316L	ON DEMAND	WEAR RING <sup>(A)</sup>	AISI 316L	AISI 316L	AISI 316L	AISI 316L	ON DEMAND	WEAR PLATE <sup>(B)</sup>	AISI 316L	AISI 316L	AISI 316L	AISI 316L	ON DEMAND
DESCRIPTION	PUMP MATERIAL CODE																																																																	
	0	1	2	3	S																																																													
CASING	GJL 250	GJL 250	GJL 250	CF8M (AISI 316)	ON DEMAND																																																													
CASING COVER	GJL 250	GJL 250	GJL 250	CF8M (AISI 316)	ON DEMAND																																																													
IMPELLER	CF8M (AISI 316)	GJL250/GJS400	CF8M (AISI 316)	CF8M (AISI 316)	ON DEMAND																																																													
SHAFT	C45	C45	AISI 316	AISI 316	ON DEMAND																																																													
SHAFT SLEEVE	AISI 316L	AISI 420	AISI 316L	AISI 316L	ON DEMAND																																																													
LANTERN	GJL200/GJL250/S 235 JR	GJL200/GJL250/S 235 JR	GJL200/GJL250/S 235 JR	GJL200/GJL250/S 235 JR	GJL200/GJL250/S 235 JR																																																													
IMPELLER HUB	AISI 316L	AISI 316L	AISI 316L	AISI 316L	ON DEMAND																																																													
WEAR RING <sup>(A)</sup>	AISI 316L	AISI 316L	AISI 316L	AISI 316L	ON DEMAND																																																													
WEAR PLATE <sup>(B)</sup>	AISI 316L	AISI 316L	AISI 316L	AISI 316L	ON DEMAND																																																													
<p>(A) ONLY FOR RD-RB TYPE (B) ONLY FOR RG-RE TYPE</p>																																																																		
9	<p><b>RELEASE</b></p> <ul style="list-style-type: none"> <li>If applicable, specify the pump release (ie: A-B-C)</li> </ul>																																																																	

## 1.4. GROUP PARTITION

For the same size, the group can change in according to the motor polarity. Below group partition table:

SIZE	RD			RG			RN			RC			RB-RE		
	GROUP			GROUP			GROUP			GROUP			GROUP		
	2P	4P	6P	2P	4P	6P	2P	4P	6P	2P	4P	6P	2P	4P	6P
32-12	-	-	-	-	-	-	1	1	1	-	-	-	-	-	-
32-16	1	1	-	1	1	-	1	1	1	1	1	1	-	-	-
32-20	1	1	-	1	1	-	1	1	1	1	1	1	-	-	-
40-12	-	-	-	-	-	-	1	1	1	-	-	-	-	-	-
40-16	1	1	-	1	1	-	1	1	1	-	-	-	-	-	-
40-20	1	1	-	1	1	-	1	1	1	-	-	-	-	-	-
40-25	-	-	-	-	-	-	2	2	2	-	-	-	-	-	-
50-12	-	-	-	-	-	-	1	1	1	-	-	-	-	-	-
50-16	1	1	-	1	1	-	1	1	1	1	1	1	-	-	-
50-20	1	1	-	1	1	-	1	1	1	1	1	1	-	-	-
50-25	2	2	-	2	2	-	2	2	2	2	2	2	-	-	-
65-12	-	-	-	-	-	-	1	1	1	-	-	-	-	-	-
65-16	2	2	-	2	2	-	2	2	2	-	-	-	-	-	-
65-20	2	2	-	2	2	-	2	2	2	2	2	2	2	2	2
65-25	2	2	-	2	2	-	2	2	2	-	-	-	-	-	-
65-31	3	2/3	2/3	-	2/3	2/3	-	2/3	2/3	-	-	-	-	-	-
80-16	2	2	-	2	2	-	2	2	2	-	-	-	-	-	-
80-20(S)	2	2	-	2	2	-	2	2	2	2	2	2	2	2	2
80-25	2	2	-	2	2	-	2	2	2	2	2	2	2	2	2
80-31	3	2/3	2/3	-	2/3	2/3	-	2/3	2/3	-	3	2/3	-	2/3	2/3
80-40	-	-	-	-	-	-	-	3	2/3	-	-	-	-	-	-
100-20	2	2	2	2	2	2	2	2	2	-	-	-	-	-	-
100-25	2/3	2/3	2/3	3	2/3	2/3	2	2	2	-	2	2	-	2	2
100-31	3	2/3	2/3	-	3	2/3	-	2/3	2/3	-	-	-	-	-	-
100-40	-	3	2/3	-	3	3	-	3	2/3	-	-	-	-	-	-
125-25	2/3	2/3	2/3	-	2/3	2/3	2	2	2	-	2	2	-	2	2
125-31	-	3	3	-	3	2/3	3	2/3	2/3	-	3	2/3	-	2/3	2/3
125-40	-	3	2/3	-	3	3	-	3	2/3	-	-	-	-	3	*
150-31	-	-	-	-	-	-	-	3	3	-	3	2/3	-	2/3	2/3
150-35	-	-	-	-	-	-	-	-	-	-	4	4	-	4	4
150-40	-	-	-	-	-	-	-	3	3	-	-	-	-	-	-
200-35	-	-	-	-	-	-	-	-	-	-	4	4	-	4	4
250-35	-	-	-	-	-	-	-	-	-	-	4	4	-	4	4

\* RB=2/3 ; RE=3

## 2. GENERAL INFORMATION

### 2.1. ADDRESSEES

**This manual is destined to operators in charge of dealing with the pump in all the stages of its technical life.**

This manual provides instructions and information valid only for the pumps to which it is attached and does NOT constitute an instruction manual for the system in which the pumps are inserted.

It also contains the subjects regarding the proper use of the pump, in order to maintain the functional and qualitative features of the machine unaltered over time. All information and warnings for proper safe use are also reported.

The manual, like the EC conformity certificate, is an integral part of the pump and must always accompany it in every displacement or property transfer. The user must keep this documentation intact and make it available for consultation during the entire lifetime of the pump.

### 2.2. SUPPLY AND PRESERVATION

The manual is provided in **printed** format.

Keep this manual with the pump so that it can be easily consulted by the operator.

The manual is an integral part for the purpose of safety, therefore:

- it must be kept intact (in all its parts). Should this manual get damaged or spoiled, request a copy immediately.
- It must accompany the pump until its demolition (even if moved, sold, leased, rented, etc.);
- the attached manuals are a part of this documentation and the same recommendations/prescriptions contained in this manual apply to them.
- For pumps compliant with directive 2014/34/EU (ATEX), an addendum is provided together with this manual, which is to be considered an integral part of the manual itself.

Salvatore Robuschi & C. S.r.l. shall not be held liable for improper use of the pump and/or damages resulting from operations not indicated in the technical documents.

### 2.3. USE AND KNOWLEDGE OF THE MANUAL

The personnel involved must be qualified for the installation, control and maintenance of the machine to which this manual refers. The latter must be read and understood in all its points, both by the personnel manager and by the operators who will carry out the work before installation and commissioning.

The manual must always be available for consultation.



#### **IMPORTANT!**

**This manual is supplied with the pump, guaranteeing user guidelines for the correct installation, routine maintenance and disposal of the machine.**

**It is mandatory for the user to read the manual in all its points before performing any type of work on the pump. Work must always be carried out in total safety by qualified personnel who are familiar with the rules below.**

### 2.4. SYMBOLS USED IN THE MANUAL

Graphic symbols have been used throughout this manual to facilitate comprehension and point out the different risk levels that may be incurred during operation of the machine.

Listed below are the symbols and their meanings:

SYMBOL	DEFINITION
	Symbol used to identify important warnings for the safety of the operator and/or the pump.
	Symbol used to identify particularly important information in the manual. The information also regards the safety of personnel involved in pump use.
	Symbol used to indicate a general prohibition.

## 2.5. DIRECTIVES OF REFERENCE

To certify the conformity of the pump with the provisions of the Directive, Salvatore Robuschi & C. S.r.l., before placing it on the market, has assessed the risks in order to verify compliance with the essential health and safety requirements provided by Directive 2006/42/EC as well as the tests and checks provided by the applied standards of reference.

Also note that the pump has been designed in accordance with the following Directives and/or Standards:

REF.	SUBJECT MATTER
2006/42/EC	MACHINERY DIRECTIVE
2011/65/EU	RoHS COMPATIBILITY DIRECTIVE
2014/30/EU	ELECTROMAGNETIC COMPATIBILITY DIRECTIVE
2014/35/EU	LOW VOLTAGE DIRECTIVE
EN 809:2009	PUMPS AND PUMP UNITS FOR LIQUIDS - COMMON SAFETY REQUIREMENTS
EN 12100:2010	SAFETY OF MACHINERY - GENERAL PRINCIPLES FOR DESIGN - RISK ASSESSMENT AND RISK REDUCTION
EN 13857:2008	SAFETY OF MACHINERY - SAFETY DISTANCES TO PREVENT HAZARD ZONES BEING REACHED BY UPPER AND LOWER LIMBS

## 2.6. WARRANTY

The warranty conditions are defined in the "General conditions of sale of Salvatore Robuschi & C. S.r.l." sent together with the order confirmation.

## 2.7. TESTING

Salvatore Robuschi & C. S.r.l. pumps are carefully tested through a control plan that includes:

- Hydrostatic test of the main hydraulic parts subjected to pressure
- Impeller balancing
- Visual check before shipping.
- Tests or other documents performed upon request of the customer and in accordance with that indicated in the order confirmation.

## 2.8. DOCUMENTS SUPPLIED

Salvatore Robuschi & C. S.r.l. pumps are equipped with:

- CE Marking
- EC Declaration of Conformity
- Manual for installation, start-up and routine maintenance (documentation according to Machinery Directive 2006/42/EC, section 1.7.4)
- Atex Addendum (only for pumps compliant with ATEX directive 2014/34/EU)
- Addendum for partly completed machines (for pumps supplied without motor)
- Test certificates if specified in the order confirmation

## 2.9. LIST OF DOCUMENTS AVAILABLE ONLINE

In addition to this manual, additional documents are available on our website [www.salvatorerobuschi.com](http://www.salvatorerobuschi.com) (www.srpumps.com), which can be consulted free of charge, such as: Performance Curves, Dimensions, Sections with nomenclature (BOM), Addendum.

### 3. SAFETY RULES









**CAUTION!**

Failure to comply with the information in this manual may cause the pump to malfunction and cause problems for which Salvatore Robuschi & C. S.r.l. is not responsible.

#### 3.1. PERSONAL PROTECTIVE EQUIPMENT

When operating near the line for assembly and maintenance and/or adjustment operations strictly respect the main accident-prevention rules. For this purpose it will be mandatory to use the personal protective equipment (P.P.E.) required for each individual operation.

























Below is the full list of Personal Protective Equipment (P.P.E.) that may be required for the different procedures:

SYMBOL	DESCRIPTION
	<b>COMPULSORY USE OF PROTECTIVE OR INSULATING GLOVES</b> Indicates a requirement for personnel to use protective or insulating gloves.
	<b>COMPULSORY USE OF SAFETY FOOTWEAR</b> This marks the requirement for staff to use work-safety footwear to protect their feet.
	<b>COMPULSORY USE OF PROTECTIVE HELMET</b> This marks the requirement for staff to use a protective helmet.
	<b>COMPULSORY USE OF PROTECTIVE CLOTHING</b> Indicates a requirement for personnel to wear the specific protective clothing.
	<b>COMPULSORY USE OF PROTECTIVE GOGGLES</b> This marks the requirement for staff to use protective goggles.
	<b>OBLIGATION TO WEAR EARMUFFS AGAINST NOISE</b> Indicates a requirement for personnel to use earmuffs or earplugs to protect hearing.

The clothing worn by individuals running the line or performing maintenance must comply with the essential safety requirements defined by Reg. EU 2016/425 and the regulations in force in the country where it is installed.

### 3.2. RESIDUAL RISKS

The pump was designed to guarantee the essential safety requirements for the operator.

Risk	PPE	Description
Impact/tripping hazard	  	Residual risk of impact and tripping on the edges of the machinery structure during normal use or in normal cleaning and maintenance operations.
Crushing hazard	   	Residual risk of crushing due to falling machine during movement operations.
Danger of burns and scalds	  	Residual risk of burning and scalding during normal use or in normal cleaning and maintenance.
Danger of impact, dragging, crushing, shearing.	  	Residual risk of impact, dragging, scrushing, shearing during use. It is forbidden to access the moving parts of the pump during its operation. It is mandatory to wear appropriate PPE.
High voltage/electrocution hazard	  	Residual risk of contact with electrical surfaces during installation, commissioning and use.
Danger of high noise level		Residual risk of high noise levels for pumps with noise levels above 85 dB(a) during use. It is mandatory to wear appropriate PPE.
Danger of external effects on electrical devices		Residual risk of external effects on electrical devices.  <b>FORBIDDEN!</b> People with pacemakers should not approach live motors.
Danger of cutting/shearing	  	Residual risk of cutting and shearing on moving machine parts during maintenance, cleaning and unlocking. It is mandatory to wear appropriate PPE.
High-pressure fluid injection or ejection hazard	   	Residual risk of unexpected ejection of machine components or fluids during use. It is mandatory to wear appropriate PPE.



**CAUTION!**

Failure to comply with the information in this manual may cause the pump to malfunction and cause problems for which Salvatore Robuschi & C. S.r.l. is not responsible.



**CAUTION!**

It is forbidden to use the pump without its safety devices/shields.

### 3.3. SAFETY REQUIREMENTS

The customer guarantees that every maintenance, inspection and installation job is carried out by qualified personnel who are fully aware of the contents of this manual.

In order to avoid damage to property or persons, it is mandatory to observe all the following requirements:

#### 3.3.1. SAFETY INFORMATION FOR OPERATOR / USER (EXCLUDING INSTALLATION, MAINTENANCE AND DISASSEMBLY OPERATIONS)

- Pacemaker wearers are prohibited from approaching live electric motors.
- Operators and persons approaching the pump must be adequately informed about the location of the first aid stations present in the company and about the current safety and first aid requirements.
- It is good practice to know the location of the nearest fire-fighting equipment.
- Only approach the pump in the presence of qualified personnel and after having expressly received authorisation from the safety officer.
- Only approach the pump with suitable clothing, avoiding any clothing or objects that could get tangled and be dragged by the rotating parts of the pump (necklaces, pendants, ties, scarves, long loose hair ...).
- Only approach the pump with personal protective equipment suitable for the environment, the operations to be carried out and in compliance with the local regulations in force. Ear protection, helmet, goggles, gloves and safety shoes are recommended, in addition to the devices indicated by the factory procedures and by the safety officer.
- **IT IS FORBIDDEN** to remove the guards of the coupling or of the rotating shafts and any other safety protection during operation of the machine.
- Check the temperature of the pump and pipes before touching them. For temperatures below 5°C and higher than 45°C, take the necessary precautions and use adequate wear-resistant personal protective equipment.
- If the pump and piping contain dangerous or corrosive liquids, take the necessary precautions and use adequate wear-resistant personal protective equipment.
- If the pump is supposed to work with cold, warm or dangerous liquid, the necessary cautions have to be taken to prevent any possible accident.
- Ensure there is an earthing connection.
- Check the conformity of the performance with the order confirmation using the installed pressure gauges (or other instruments).
- In the event of excessive vibrations or noise, switch off the pump and check the cause before operating on the system.

### 3.4. NOISE

Noise levels have been measured in accordance with the requirements of UNI EN 11200 and UNI EN ISO 3746 standards. During the operating cycles, exposure of personnel to noise is less than 85 dB unless otherwise specified on the operating curves, unless the noise generated by the curves, valves, section changes etc. present on the system is added to the pump noise.

It is mandatory to check the general operating curve of the pump in order to check the characteristic noise values, where present, before starting it up.

Once the pump and plant noise has been verified, it is the user's responsibility to apply the consequent preventive and protective measures, in compliance with the legislation of the country where the pump is installed.

Tables 1 - 2 - 3 indicate the noise values for each type of pump (series-size).

Table 4 summarises some typical noise values for three-phase electric motors; the actual noise pressure values may vary depending on the brand and model of the motor actually installed on the electric pump unit.

### 3.5. VIBRATIONS

The vibrations produced by the pump, depending on its method of operation, **are not dangerous** for the workers' health.



**CAUTION!**

**An excessive vibration can only be caused by a mechanical fault that must be immediately reported and eliminated to avoid jeopardising the safety of the line and its operators.**

Tables 1 - 2 - 3 show the maximum permissible vibration values and the relative reference standards for each type of pump (series-size). These values are intended as measurements of unfiltered vibrations evaluated in the radial direction on the bearing housings at the point of operation at maximum efficiency (BEP).

SERIES	SIZE	NOISE (Lp) [dB(A)]		VIBRATIONS (UNI ISO 5199:2005) [mm/s]
		2 poles	4-6-8 poles	-
RD/RG/RN	32-16	< 70	< 70	7.1
	40-16	< 70	< 70	7.1
	50-16	< 70	< 70	7.1
	65-16	< 74	< 70	7.1
	80-16	< 74	< 70	7.1
	32-20	< 70	< 70	7.1
	40-20	< 70	< 70	7.1
	50-20	< 70	< 70	7.1
	65-20	< 75	< 70	7.1
	80-20	< 75	< 70	7.1
	100-20	< 76	< 70	7.1
	50-25	< 74	< 70	7.1
	65-25	< 76	< 70	7.1
	80-25	< 76	< 70	7.1
	100-25	< 77	< 70	7.1
	125-25	< 82	< 76	7.1
	65-31	< 82	< 72	7.1
	80-31	< 82	< 74	7.1
	100-31	< 82	< 76	7.1
	125-31	< 82	< 76	7.1
100-40	-	< 76	7.1	
125-40	-	< 76	7.1	

Table 1 - Vibration and noise values for RD/RG/RN series

SERIES	SIZE	NOISE (Lp) [dB(A)]		VIBRATIONS (UNI ISO 5199:2005) [mm/s]
		2 poles	4-6-8 poles	-
RB/RE	65-20	< 77	< 70	7.1
	80-20	-	< 76	7.1
	80-25	-	< 76	7.1
	100-25	-	< 76	7.1
	125-25	-	< 76	7.1
	80-31	-	< 76	7.1
	125-31	-	< 76	7.1
	150-31	-	< 76	7.1
	125-40	-	< 76	7.1
	150-35	-	< 85	7.1
	200-35	-	< 85	7.1
	250-35	-	< 85	7.1
	200-45	-	< 91	7.1
	250-45	-	< 91	7.1
	300-45	-	< 91	7.1
300-46	-	< 91	7.1	

Table 2 - Vibration and noise values for RB/RE series

SERIES	SIZE	NOISE (Lp) [dB(A)]		VIBRATIONS (UNI ISO 5199:2005) [mm/s]
		2 poles	4-6-8 poles	-
RC	32-16	< 77	< 72	7.1
	50-16	< 77	< 72	7.1
	32-20	< 77	< 72	7.1
	50-20	< 77	< 72	7.1
	65-20	< 85	< 72	7.1
	80-20	-	< 72	7.1
	80-20S	-	< 75	7.1
	50-25	-	< 80	7.1
	80-25	-	< 80	7.1
	100-25	-	< 84	7.1
	125-25	-	< 84	7.1
	80-31	-	< 90	7.1
	125-31	-	< 90	7.1
	150-31	-	< 94	7.1
	150-35	-	< 94	7.1
	200-35	-	< 94	7.1
	250-35	-	< 94	7.1

Table 3 - Vibration and noise values for RC series

POWER / POLES	NOISE PRESSURE (Lp) [dB(A)]			NOISE PRESSURE (Lp) [dB(A)] (ATEX)		
	2 poles	4 poles	6 poles	2 poles	4 poles	6 poles
0.75	57	47	48	62	51	46
1.1	57	51	48	62	54	46
1.5	62	51	52	69	54	55
2.2	62	52	54	69	55	57
3	66	52	57	72	55	60
4	67	55	57	72	60	60
5.5	70	57	57	73	64	60
7.5	70	57	61	75	67	64
9.2	73	60	-	75	67	-
11	76	62	61	76	69	64
15	76	62	61	76	69	67
18.5	76	64	65	76	70	69
22	79	65	65	74	70	69
30	81	66	65	77	72	70
37	81	70	66	77	73	70
45	81	70	68	79	73	70
55	82	72	68	79	75	65
75	83	75	70	76	70	65
90	84	75	70	76	70	65
110	86	78	81	76	71	65
132	86	78	71	85	76	70
160	87	80	72	85	76	70
200	87	80	73	85	76	70
250	90	84	73	88	80	72
315	90	87	76	88	80	72

Table 4 - Indicative noise emission values for three-phase motors

Graph 1 shows how to calculate the total noise emission of the pump-motor unit starting from the information contained in the tables above.

Calculate the difference between the two sources. Identify the value obtained on the X axis and calculate the Y value (increase in dB) on the curve and add it to the higher value between pump and motor.

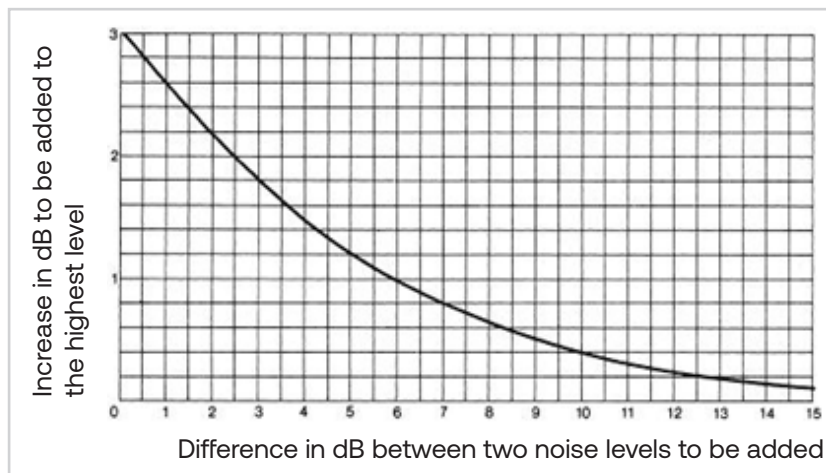

Graph 1 - Calculation of the dB increase for two noise sources

## 4. RECEIPT, HANDLING AND STORAGE

### 4.1. PACKAGING

The pump is assembled by Salvatore Robuschi & C. S.r.l. and packaged as indicated in the order confirmation. The packaging is made in accordance with the mode of transport. If handled with due care it is able to withstand minor impacts but cannot withstand falls or stacked loads.

#### 4.1.1. REMOVAL OF PACKAGING AND HANDLING

When removing the packaging, take care to:

- Not damage the contents within.
- Correctly dispose of any waste.

The pump mouth guards must be removed only before connecting it to the pipes. In the event of removal for inspection purposes, the protections must be put back, at the end of the operation, in the same way and in the conditions in which they were found.

### 4.2. CHECKING ON RECEIPT

The material leaves Salvatore Robuschi & C. S.r.l. intact in all its parts and always travels at the risk of the recipient. At machine delivery, the customer is obliged to check that there is no damage caused by transport. In case of damage, please follow the instructions below:

- Leave the packaging as you received it, write the phrase "Ritiro con riserva" (Withdrawal under reserve) on the transport document
- Immediately ask the shipping company to verify the damage.
- Report the damage detected to Salvatore Robuschi & C. S.r.l..

### 4.3. TRANSPORT AND HANDLING

Salvatore Robuschi & C. S.r.l. uses packages and fixing systems suitable to ensure the integrity and proper conservation during transport, according to the means of transport used.

The handling procedures described in this paragraph shall be carried out by staff trained for such operations: suitably trained personnel to safely perform loading, unloading and handling operations by means of lifting equipment, and aware of accident-prevention rules.



#### CAUTION!

Salvatore Robuschi & C. S.r.l. shall not be held liable for any damage, to things or people, caused by accidents due to a failure to comply with the instructions provided in this manual.

#### 4.3.1. TRANSPORTATION OPERATIONS



#### CAUTION!

Salvatore Robuschi & C. S.r.l. disclaims any liability for any damage to the component arising from failure to comply with the instructions provided.



#### IMPORTANT!

The lifting personnel must be authorised and trained to use the lifting equipment and devices, and must comply with the applicable regulations for personal protection.



#### IMPORTANT!

Before and during any type of handling operation of the pump, it is mandatory to take all the safety precautions dictated by the regulations in force on site and the internal ones of the company / plant where it will be installed.

## TRANSPORT WITH FORKLIFT TRUCK

<b>Operator qualification</b>	Lifting equipment operator
<b>Necessary PPE</b>	
<b>Lifting equipment</b>	Forklift truck



**CAUTION!**

Only use suitable and approved lifting equipment, compatible for the dimensions and weight of the goods.







**CAUTION!**

Make sure nobody stops under and within the range of the lifting equipment.

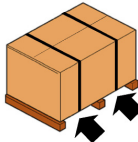
Risk	Description and procedural information
<b>Impact/crushing hazard</b>	 Danger of impact and crushing during handling phases. It is mandatory to wear appropriate PPE.

To carry out the transport correctly, proceed as described:

STEP	ACTION	PICTURE
1	Place the forks of the forklift under the load surface.	
2	Make sure that the forks come out from the front of the load (at least 5 cm) to eliminate any risks of overturning of the transported part.	
3	Lift the forks until they are touching the load. <b>Note: if necessary fix the load to the forks with clamps or similar devices.</b>	
4	Slowly lift the load by a few tens of centimetres and check it is stable, making sure that the load's centre of gravity is positioned in the centre of the lifting forks.	
5	Tilt the upright backwards (towards the driver's seat) to facilitate the tilting moment and guarantee greater stability of the load during transport.	
6	Adapt the transport speed according to the flooring and type of load, avoiding sudden manoeuvres.	
7	Place the load in the chosen area.	

## HANDLING WITH CRANE OR GANTRY

<b>Operator qualification</b>	Lifting equipment operator
<b>Necessary PPE</b>	
<b>Lifting equipment</b>	Crane or Gantry



**CAUTION!**  
Only use suitable and approved lifting equipment, compatible for the dimensions and weight of the goods.



**CAUTION!**  
Make sure nobody stops under and within the range of the lifting equipment.

Risk	Description and procedural information
<b>Impact/crushing hazard</b> 	Danger of impact and crushing during handling phases. It is mandatory to wear appropriate PPE.

To correctly carry out handling, proceed as described:

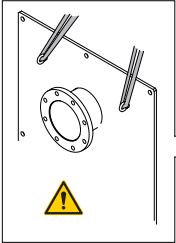
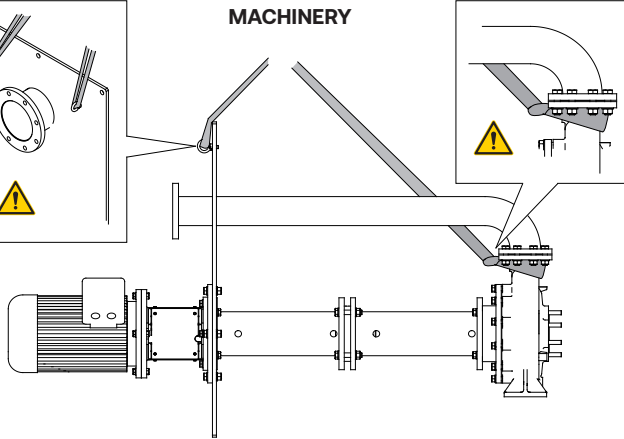
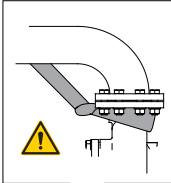
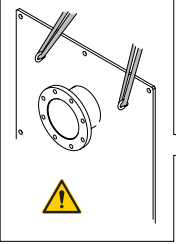
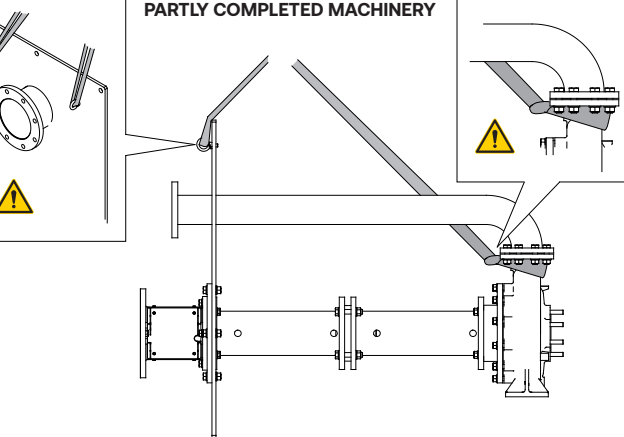
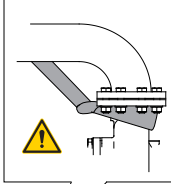
STEP	ACTION
1	Connect the belts / straps to the component in the appropriate grip points, depending on the type of pump to be moved - see image below.
<div style="display: flex; justify-content: space-around;"> <div style="border: 1px solid black; padding: 5px;">  </div> <div style="text-align: center;"> <p><b>MACHINERY</b></p>  </div> <div style="border: 1px solid black; padding: 5px;">  </div> </div>	
<div style="display: flex; justify-content: space-around;"> <div style="border: 1px solid black; padding: 5px;">  </div> <div style="text-align: center;"> <p><b>PARTLY COMPLETED MACHINERY</b></p>  </div> <div style="border: 1px solid black; padding: 5px;">  </div> </div>	

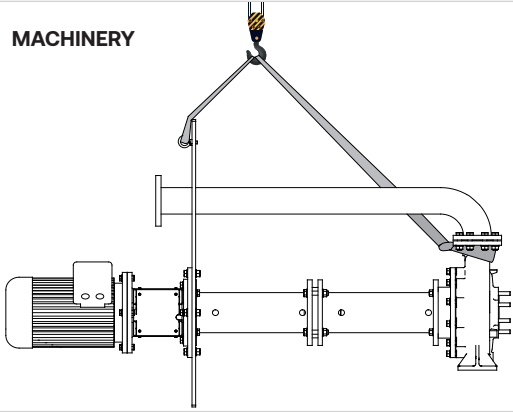
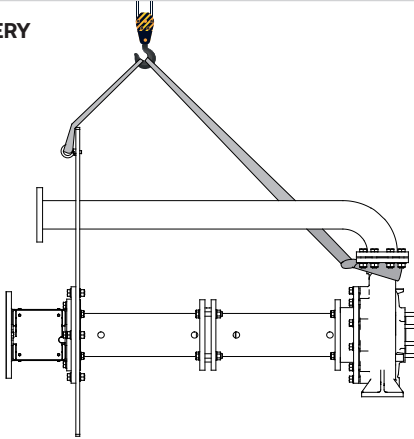
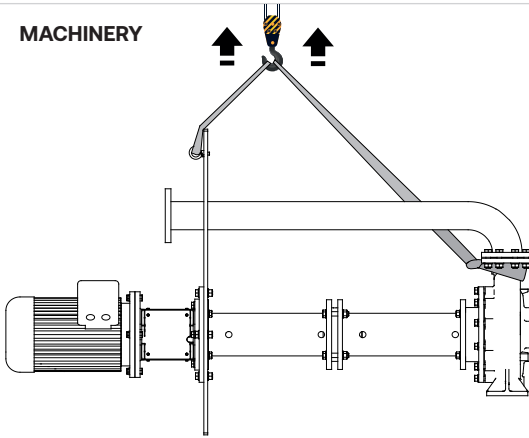
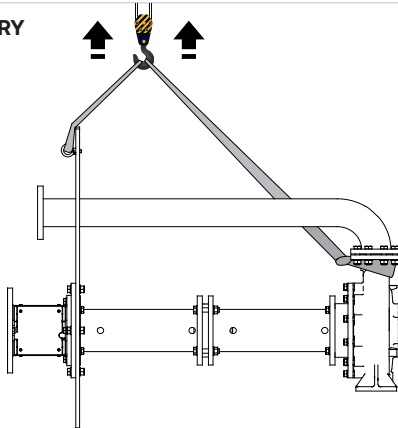
STEP	ACTION
2	Connect the belts / straps to the hook of a crane or gantry.
	<p data-bbox="549 286 671 309"><b>MACHINERY</b></p> 
	<p data-bbox="331 689 667 712"><b>PARTLY COMPLETED MACHINERY</b></p> 
3	Slowly lift the load completely out from the package and check it is stable, making sure that the centre of gravity of the pump is positioned in the centre of the lifting hook. Make sure that the pump is always properly balanced and in a horizontal position.
	<p data-bbox="539 1245 667 1267"><b>MACHINERY</b></p> 
	<p data-bbox="341 1675 676 1697"><b>PARTLY COMPLETED MACHINERY</b></p> 

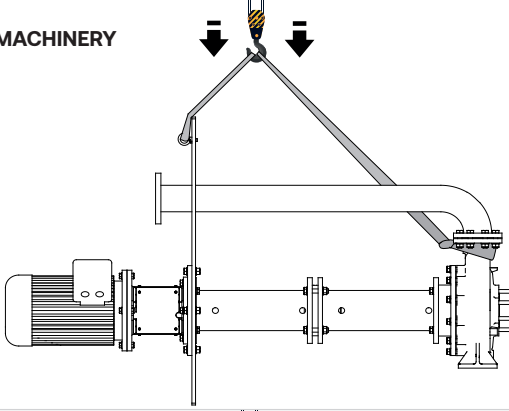
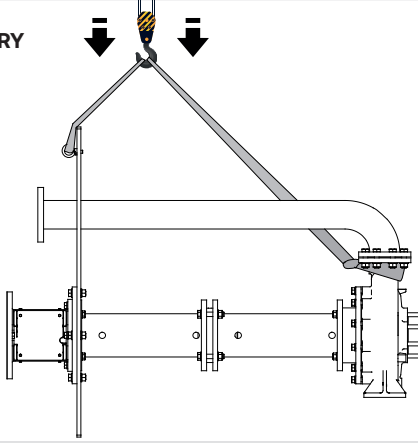
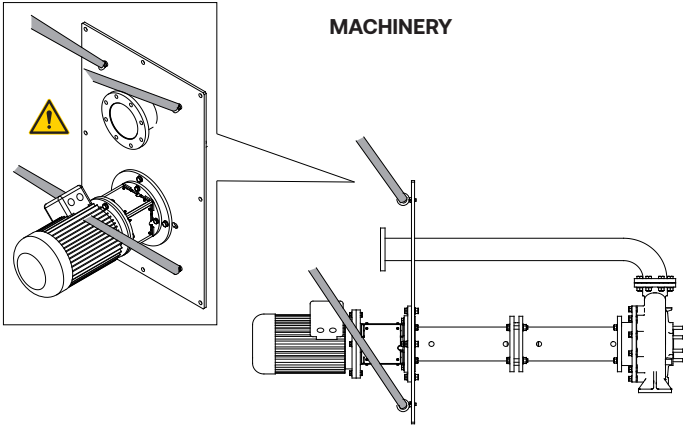
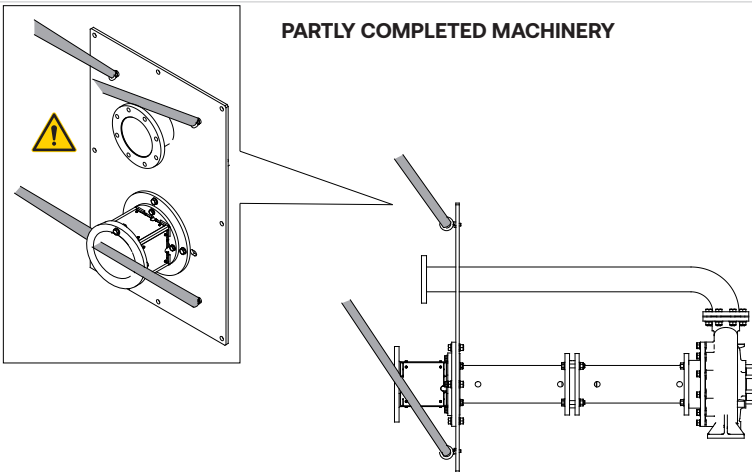
STEP	ACTION
4	After removing the pump from the wooden box, carefully lay it on the ground.
	<p data-bbox="528 297 655 320"><b>MACHINERY</b></p> 
	<p data-bbox="328 707 667 730"><b>PARTLY COMPLETED MACHINERY</b></p> 
5	Hook the belts/chains into the jacking points, as shown in the following pictures.
	<p data-bbox="778 1205 906 1227"><b>MACHINERY</b></p> 
	<p data-bbox="695 1637 1034 1659"><b>PARTLY COMPLETED MACHINERY</b></p> 

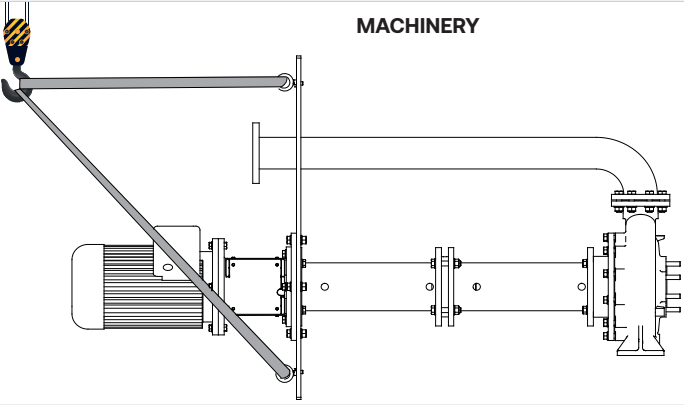
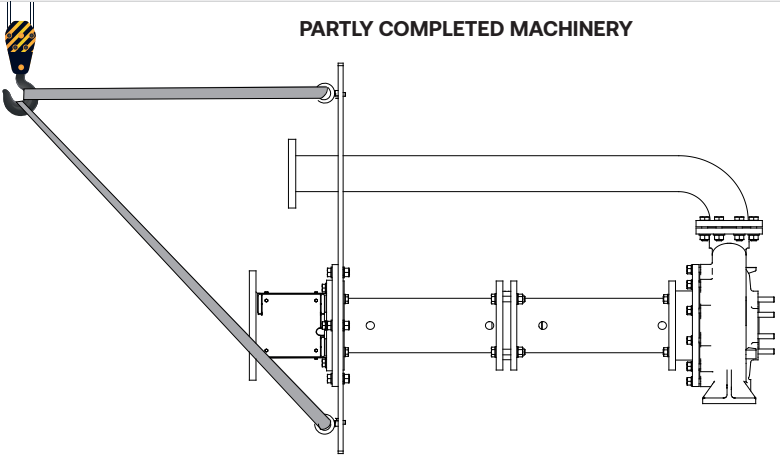
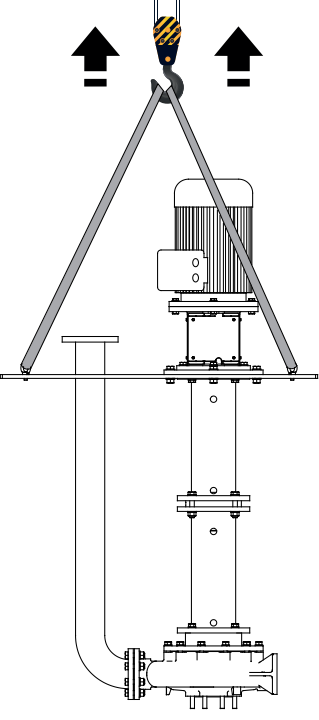
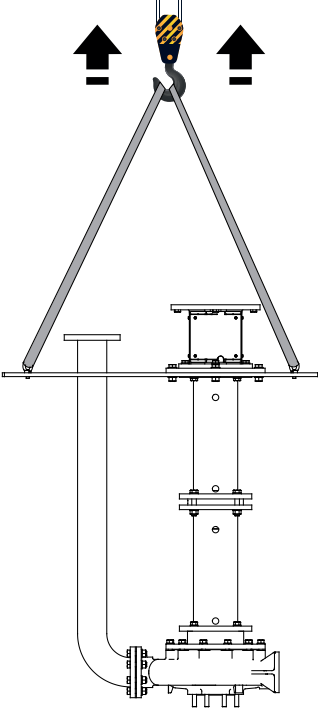
STEP	ACTION
6	Fix the belts/chains to the crane or crane system's hook.
<p style="text-align: center;"><b>MACHINERY</b></p> 	
<p style="text-align: center;"><b>PARTLY COMPLETED MACHINERY</b></p> 	
7	Lift the pump carefully, to put it into a vertical position.
<div style="display: flex; justify-content: space-around;"> <div style="text-align: center;"> <p><b>MACHINERY</b></p>  </div> <div style="text-align: center;"> <p><b>PARTLY COMPLETED MACHINERY</b></p>  </div> </div>	
8	Place the pump in the chosen area.

#### 4.4. STORAGE

If the pump is not installed on the plant within 30 days of delivery, it must:

- Be checked
- Packaged again
- Stored with the correct precautions.



**NOTE!**

**It is advisable to install the pump within 3 months of leaving the factory, otherwise follow the instructions below.**

For correct storage it is necessary to comply with the following provisions:

- Store the pump in an enclosed, dry, clean place that is not directly exposed to solar radiation and any type of vibration.
- Avoid places where the ambient temperature is lower than 4°C
- Close any holes that can connect the inside of the pump with the outside. (Only during storage)
- Protect the outside of the pump by waterproof sheets

## 5. FEATURES

### 5.1. PERFORMANCE AND OPERATING LIMITS

Flow rate and Head, if specified by the customer, are present on the plate.

The technical specifications of the pump are contained in the datasheet received in the order confirmation.

The pump can only be used for the conditions and liquids specified in the datasheet attached to the order confirmation.

If the limits are not specified, the following applies:

- Flow rate for short periods of operation:  $Q_{min} = 10\%$  of the flow rate at the BEP (BEP = best performance point)
- Flow rate in continuous operation:  $Q_{min} = 30\%$  of the BEP flow rate
- Maximum flow rate:  $Q_{max} = 85\%$  of the curve bottom flow rate (If a flow meter is not available refer to the head at that point multiplied by the specific weight of the pumped liquid).
- Tank/basin pressure = Atmospheric pressure

If the data sheet does not contain the working conditions, follow the instructions below:

- Clean liquid
- Non-aggressive liquid (it is the responsibility of the installer / user to check that the pump materials are suitable for the pumped liquid and the working temperature)
- Specific weight  $1 \text{ kg/dm}^3$
- Viscosity 1 cPs
- Liquid temperature MAX  $50^\circ\text{C}$
- Atmospheric suction pressure
- Frequency 50 HZ

For operation outside the above limits, request an update from Salvatore Robuschi & C. S.r.l. specifying the model and serial number of the pump. Table 5 shows the maximum permissible pressure values in the pump casing (design pressure). These values are valid for clean water at a temperature of  $20^\circ\text{C}$ .



#### CAUTION!

The design pressure is not the working pressure and can only be reached if the pump is equipped with adequate seals.

PUMPS	DESIGN PRESSURE	HYDROSTATIC TEST PRESSURE
RD	16 bar	24 bar
RG	16 bar	24 bar
RB	10 bar	15 bar
RC	10 bar	15 bar
RN	10 bar	15 bar
RE	10 bar	15 bar

Table 5 - Design pressure

### 5.2. PERMITTED ENVIRONMENTAL CONDITIONS

The permitted environmental conditions for the correct operation of the pump are those agreed with the customer and shown on the datasheet attached to the order confirmation. If not otherwise specified in the datasheet, the following conditions are to be considered valid:

PERMITTED ENVIRONMENTAL CONDITIONS	
Temperature	$-20^\circ\text{C} \leq T \leq +40^\circ\text{C}$
Environment	Non aggressive
Altitude	$< 1000\text{m}$
Installation	Indoor

### 5.3. LIMITS FOR ATEX PUMPS



For pumps operating in areas at risk of explosion and certified according to the 2014/34/EU directive, the actions provided in the specific Addendum accompanying the machine must be implemented and available, in the event of loss or wear, on the site [www.salvatorerobuschi.com](http://www.salvatorerobuschi.com).

## 6. INSTALLATION

PUMP INSTALLATION	
<b>Operator qualification</b>	Specialised mechanical worker Manufacturer's technician
<b>Necessary PPE</b>	
<b>Tools to be used</b>	Hand tools



**CAUTION!**  
The installation operations should only be performed by specialised, authorised personnel.

Risk		Description and procedural information
<b>Crushing hazard</b>		Danger of crushing during installation stages. It is mandatory to wear appropriate PPE.
<b>High voltage/electrocution hazard</b>		Electrocution hazard during installation stages. It is forbidden to carry out work on electrical components without first switching-off the electrical power supply. It is mandatory to wear appropriate PPE.

To correctly carry out the installation, follow the following stages:

STAGE	ACTION
1	Pump installation and fixing.
2	Pipe connection and inspection.
3	Mechanical checks and preliminary checks.
4	Installation of protections (if necessary).
5	Electrical connection.

### 6.1. FOUNDATION

The surfaces on which the pump will be installed must be checked and sized by specialised technicians. The structure of the construction must be suitable for the weight and dimensions of the machine. It must be done according to the class of concrete most suited to the environment in which it will operate. (for example: XO, XC1, XS1, etc...) in compliance with the provisions of UNI EN 206: 2016 and UNI 11104: 2016 standards. Alternatively, a structure can be made in a different material but with the same structural requirements. The base support must be perfectly levelled regardless of the type of structure chosen.

### 6.2. INSTALLATION AND FIXING

To correctly carry out the installation and fixing, follow the following stages:

STAGE	ACTION
1	Lower the pump carefully into the pit / tank and let the plate lean on the foundation.
2	Level the plate on the supporting surface and fix it with bolts.
3	If required fix some spacers between the plate and the supporting surface to level it.
4	Tighten the bolts fully.

## 6.3. PIPES

### 6.3.1. MAXIMUM PERMISSIBLE LOADS

The forces and moments acting on the pump flanges due to pipeline loads can cause an excessive stress on the fixing bolts and/or break of the discharge pipe.

The maximum admissible load values on the flanges are shown in Table 6.

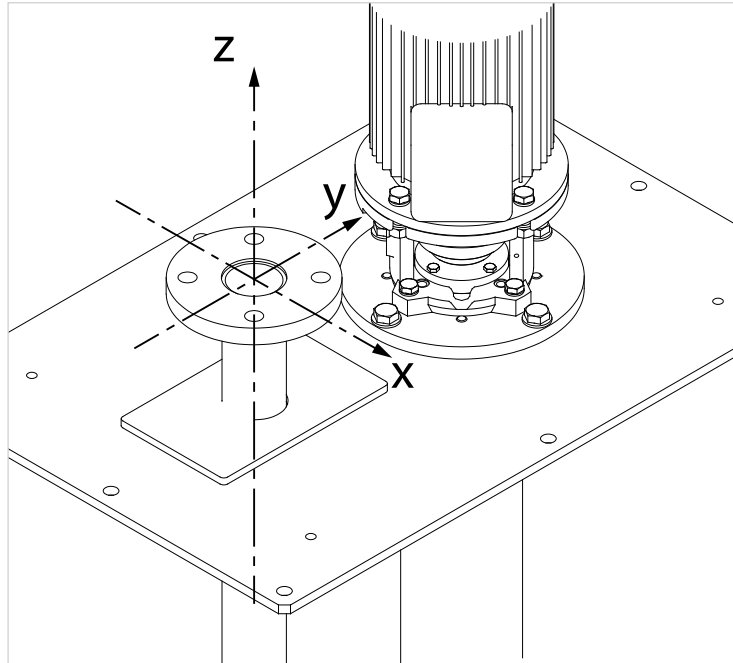

DISCHARGE PIPE (S 235 JR - STEEL)								
DN	F <sub>y</sub>	F <sub>z</sub>	F <sub>x</sub>	F <sub>tot</sub>	M <sub>y</sub>	M <sub>z</sub>	M <sub>x</sub>	M <sub>tot</sub>
32	327	404	347	625	289	327	424	608
40	385	481	424	748	347	404	501	731
50	520	635	578	1004	385	443	539	797
65	655	809	712	1261	424	462	578	852
80	789	963	866	1516	443	501	616	909
100	1040	1290	1155	2019	481	558	674	999
125	1232	1521	1367	2387	578	732	809	1234
150	1559	1925	1733	3023	674	789	963	1415
200	2079	2580	1925	4023	886	1020	1251	1848

Table 6 - Values of the maximum permissible loads

### 6.3.2. FIXING OF PIPES

Discharge pipes have to be supported independently from the pump. Be sure that pipes are installed to allow the perfect matching of flanges and counterflanges, avoiding stress transmission to the pump.

A compensation bellows is also necessary to absorb stresses or expansions caused by the temperature.

If compensation joints are installed, the pipes must be supported near the pump in such a way so it is not subjected to the thrusts caused by the lengthening of the pipes.

### 6.3.3. SUCTION AND DISCHARGE PIPES

Discharge pipe's diam shall never be smaller than pump's discharge port. Its dimensions shall be defined according to plant's requirement (length- curves no etc. ). The pumped medium max speed shall be of 2,5m/sec.. A non returned valve shall be fixed on the discharge pipe to protect the pump from excessive counter-pressure and opposite rotation after each stop. If any, the suction pipe's diam shall never be smaller than pump's suction port. Its dimensions shall be defined according to suction requirements, considering temperature product features and temperature. The suction port or free suction inlet of the suction pipe shall be at a distance of min. 1,5 diam from the wall or the bottom of the tank to avoid fluid's vortex or air inlet. In case of air into the liquid, air could be eliminated by bulkheads or similar. In case of air, pump performances would be lower than the data on the operating curve. Check the plant's NPSHa value is higher than pump's NPSHr value.

The following images show some examples of correct installation of the pump:

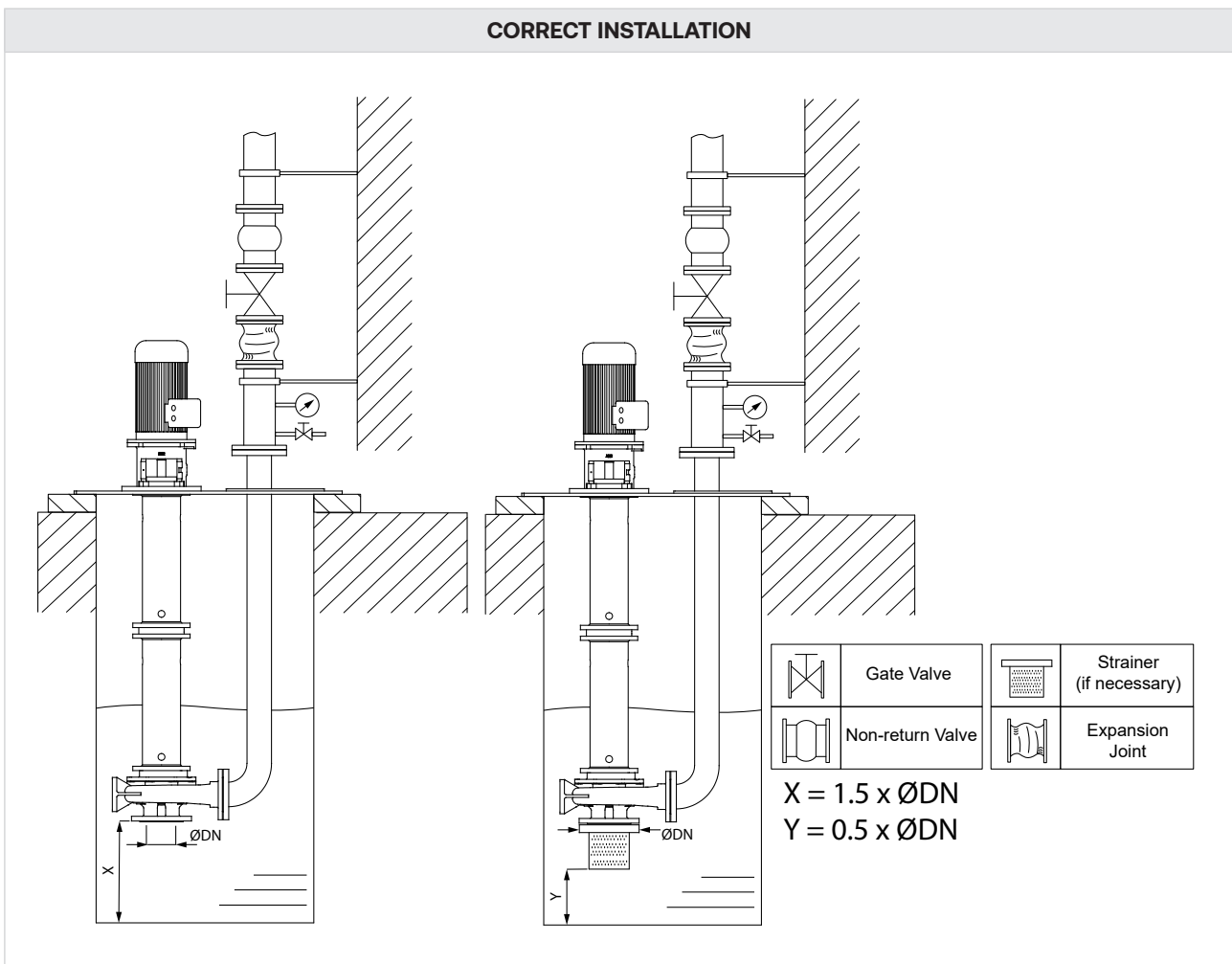

### 6.3.4. FILTERS

In presence of a strainer or other filtration system before the suction port, check solids dimensions and/or other parts in the tank are smaller than the filter's holes. Suction net surface of the filter needs to be 1.5 times bigger than suction's DN. Check periodically the solids and/or other parts in the tank do not clog the filter's holes , affecting pump performances.

### 6.3.5. VENT

Fix a 1/4" valve for air vent beyond the discharging pipe and prior to any other component. In presence of dangerous fluids, the air vent must be directed toward a safe area. The air vent is very important and it's essential during the start-up / removal to allow the proper pump's fill up/emptying.

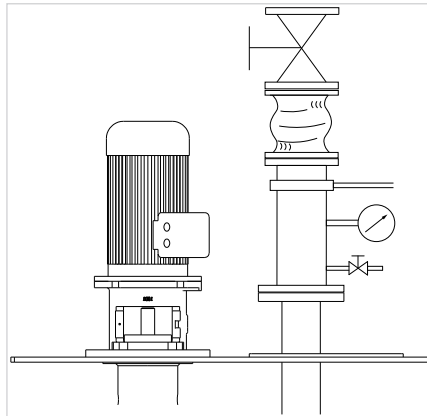

### 6.3.6. DRAIN

Vertical pumps do not require any drainage valve, because they spontaneously drain when they are lifted from the tank. Any remaining liquid in the flushing pipes or in the column are removed through a specific wash and drained through drain holes on the pump.

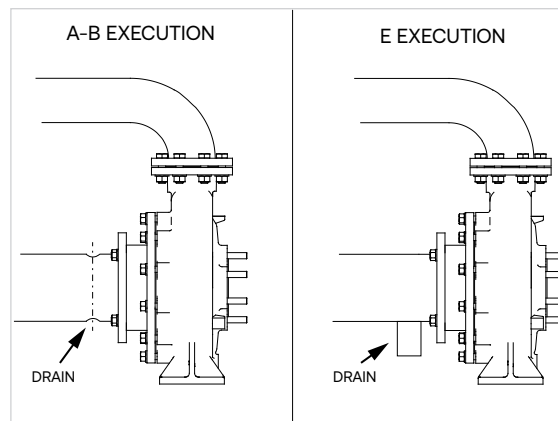

### 6.3.7. CONTROL INSTRUMENTS

Install a pressure gauge on the discharge pipe and minimum/maximum level sensors in the tank. This equipment is necessary for the proper pump's adjustment and running, also for faults detection or any plant failure. In case of any complaint concerning pump performances, it's necessary to measure the discharge pressure values stated close to the pump and levels of medium in the tank. Pressure gauge connections must be placed in a position as not to disturb measurement of valves, filters or other elements causing any pressure drops.

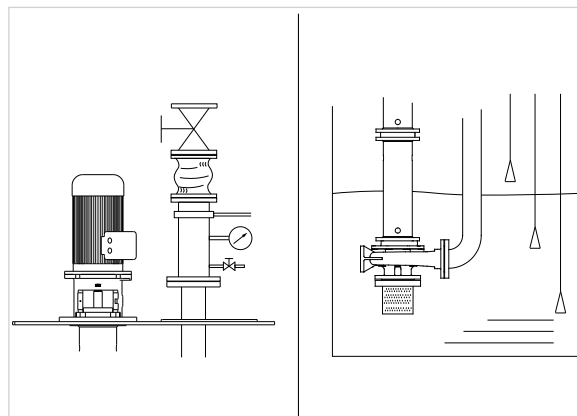

### 6.3.8. LUBRICATION SYSTEMS

Refer to APPENDIX A for instructions on correct connecting and commissioning lubrication systems. The auxiliary flushing must be connected to the connections provided on the pump. This is necessary for the correct lubrication of the mechanical seals and bearing bushings.



**IMPORTANT!**

Absence of and incorrect lubrication can lead, in addition to damage to the bearing housing and/or sealing parts, also to the triggering of combustion reactions caused by overheating due to friction.

### 6.4. MECHANICAL CHECKS AND PRELIMINARY CHECKS

Before proceeding with the commissioning of the pump, it is necessary to proceed with the following checks:

#### 6.4.1. COUPLING GUARD



**IMPORTANT!**

According to the security rules, pumps can work only if the coupling is correctly protected. If not included in the supply, it must be installed by the final user.

#### 6.4.2. ROTATION

Check that the pump rotates freely by hand.

#### 6.4.3. BEARING LUBRICATION - FIRST GREASING

##### 6.4.3.1. Lubrication with grease

The bearings: before shipping the pump the bearings are previously greased with high quality grease. After start-up, they must be refilled with the quantities indicated in the "first lubrication" table. The "group" is indicated in the "GROUP PARTITION" paragraph.

GROUP	FIRST LUBRICATION	SUBSEQUENT LUBRICATIONS
	BALL BEARING [g]	BALL BEARING [g]
1	19	5
2	37	10
2/3	37	10
3	75	15
4	131	23

Table 10 - Grease lubrication for bearings

N.L.G.I.	RECOMMENDED GREASE TYPES
3	ESSO – BEACON EP2
	MOBIL – MOBILUX EP2
	SHELL – ALVANIA EP
	GREASER

Table 11 - Grease types

## 6.5. INSTALLATION OF PROTECTIONS



### IMPORTANT!

If the pump is supposed to work with cold, warm or dangerous liquid, the necessary cautions have to be taken to prevent any possible accident.

It is compulsory to install adequate protections on the pump, on the fittings and on the pipes and put a safety perimeter around the machine so that any ejection of pressurised fluid, in the event of malfunction or corrosion of the parts, does not cause damage to property or persons.

## 6.6. ELECTRICAL CONNECTION

ELECTRICAL CONNECTION	
Operator qualification	Electrical maintenance engineer
Necessary PPE	
Tools to be used	Hand tools



### CAUTION!

The installation operations should only be performed by specialised, authorised personnel in accordance with local rules.

Risk	Description and procedural information	
High voltage/electrocution hazard		Electrocution hazard during installation stages. It is forbidden to carry out work on electrical components without first switching-off the electrical power supply. It is mandatory to wear appropriate PPE.

Before setting up the electrical connection, make sure that:

- the maintenance engineer is aware of the regulations in force in the country of installation;
- the supply voltage corresponds to the voltage indicated on the motor plate;
- the section of the electrical cables used is adequate to the absorption;
- the earthing of the circuit is in compliance with standards EN 60204-1;
- the materials used in the earthing system have adequate strength or adequate mechanical protection.
- person responsible for the installation on site must make sure that the earth connection is carried out first and that the entire system is built in compliance with the regulations in force.
- install a device for disconnection from the network.
- regarding motor protection, install a switch or a thermal relay for the current indicated on the motor plate, plus 5%.
- if available, connect the PTCs and any other probes provided.

## 7. USE



### CAUTION!

The pump must only be used for the purpose intended by Salvatore Robuschi & C. S.r.l. Salvatore Robuschi & C. S.r.l. will not be held responsible for damage caused due to improper use of the pump.

### 7.1. PRELIMINARY INSPECTIONS

The following checks must be performed before commissioning the pump.

- Check that the pump is positioned on a surface able to withstand the weight.
- Check the correct position and operation of safety devices.
- Check that the pump has been connected to the power mains.
- Check that the power supply phases are correct.
- Check that the pump is not in "Maintenance" status.

### 7.2. START-UP

Risk		Description and procedural information
Danger of impact/tripping		Risk of impact and tripping on the edges of the machine structure. It is mandatory to wear appropriate PPE.
Danger of crushing.		Danger of crushing during use. It is mandatory to wear appropriate PPE.
Danger of impact, dragging, crushing, shearing.		Danger of impact, dragging, crushing, shearing during use. It is forbidden to access the moving parts of the pump during its operation. It is mandatory to wear appropriate PPE.
Danger of cutting/shearing		Danger of cutting and shearing during unblocking. It is mandatory to wear appropriate PPE.
Danger of high noise level		Danger of high noise level near the pump during use. It is mandatory to wear appropriate PPE.
High-pressure fluid injection or ejection hazard		High-pressure fluid injection or ejection hazard during operation stages. It is mandatory to wear appropriate PPE.
Danger of burns and scalds		Danger of burns and scalds during use. It is mandatory to wear appropriate PPE. (High temperature resistant)
High voltage/electrocution hazard		Electrocution hazard during use. It is forbidden to carry out work on electrical components without first switching-off the electrical power supply. It is mandatory to wear appropriate PPE.



### FORBIDDEN!

No access to persons with active implanted cardiac devices.



### CAUTION!

The pump must never run dry.  
The pump can only be started if filled with liquid.



### CAUTION!

Observe the warnings in the safety data sheets of the liquids to be pumped.

### 7.3. CHECK THE MEDIUM LEVEL IN THE TANK



**IMPORTANT!**  
Medium's levels must be checked when the pump IS NOT RUNNING.

Before starting the pump, it's necessary to comply with minimum and maximum submergence as stated in the following table

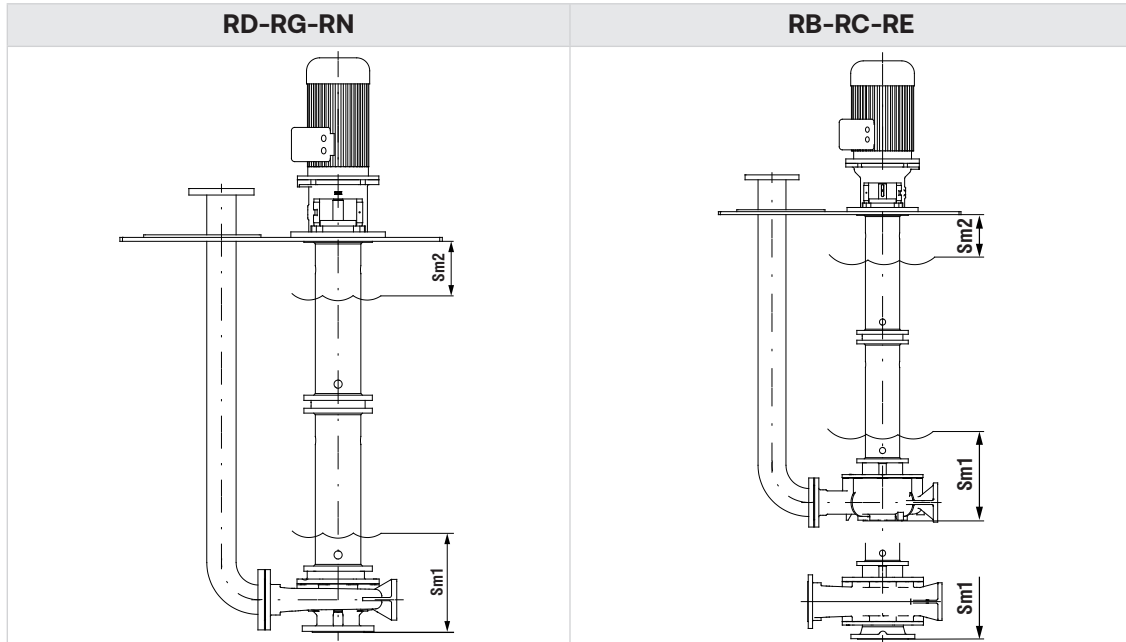

SIZE	RD-RG		RN		RC		RB-RE	
	Sm1	Sm2	Sm1	Sm2	Sm1	Sm2	Sm1	Sm2
32-12	-	-	228	130	-	-	-	-
32-16	228	130	228	130	217	130	-	-
32-20	228	130	228	130	222	130	-	-
40-12	-	-	228	130	-	-	-	-
40-16	228	130	228	130	-	-	-	-
40-20	248	130	248	130	-	-	-	-
40-25	-	-	290	130	-	-	-	-
50-12	-	-	248	130	-	-	-	-
50-16	248	130	248	130	235	130	-	-
50-20	248	130	248	130	243	130	-	-
50-25	290	130	290	130	246	130	-	-
65-12	-	-	263	130	-	-	-	-
65-16	263	130	263	130	-	-	-	-
65-20	262	130	262	130	264	130	250	130
65-25	290	130	290	130	-	-	-	-
65-31	321	130	280	130	-	-	-	-
80-16	288	130	288	130	-	-	-	-
80-20(S)	287	130	287	130	274	130	260	130
80-25	290	130	290	130	306	130	296	130
80-31	315	130	321	130	321	130	312	130
80-40	-	-	335	130	-	-	-	-
100-20	287	130	287	130	-	-	-	-
100-25	328	130	328	130	331	130	321	130
100-31	336	130	336	130	-	-	-	-

SIZE	RD-RG		RN		RC		RB-RE	
	Sm1	Sm2	Sm1	Sm2	Sm1	Sm2	Sm1	Sm2
100-40	335	130	335	130	-	-	-	-
125-25	328	130	328	130	366	130	356	130
125-31	342	130	342	130	356	130	347	130
125-40	335	130	335	130	-	-	336	130
150-31	-	-	342	130	361	130	352	130
150-35	-	-	-	-	474	130	464	130
150-40	-	-	335	130	-	-	-	-
200-35	-	-	-	-	538	130	528	130
250-35	-	-	-	-	602	130	592	130

#### 7.4. LINES OF LUBRICATION FEEDING

When flushing lines are present, open the feeding system and adjust the medium according to quantity/pressure stated in the A APPENDIX.

In case of failure or lack of flushing, pump running can be affected irreparably.

#### 7.5. ROTATION DIRECTION TEST

In case of disassembled motor, it's mandatory to check rotation direction BEFORE mounting it to the pump:



**ATTENTION!**

Comply with safety descriptions listed in the "POWER CONNECTION" paragraph.

Motor rotation must be clockwise, looking from fan side. In case of wrong rotation, invert the phases properly.

In case of pump equipped with motor, follow the instructions underneath to check the rotation direction:

STEP	ACTION
1	Start the pump for an instant with the discharge gate valve slightly open (20% opening).
2	Make sure the rotation's direction is the one shown by the arrow on the lantern: if it rotates the opposite way, swap the connections of two phases.

#### 7.6. COUPLING ASSEMBLY

When the pump is not equipped with motor, half couplings can be mounted on the motor shaft and pump shaft.

Follow the instructions underneath to assemble the motor properly:

STEP	ACTION
1	Lightly lubricate coupling elastomers with liquid soap, Vaseline or silicon oils.
2	Put the motor on the lantern flange, by fixing it with the bolts.
3	Check the half couplings are fitted without forcing them. Otherwise remove the motor and repeat the operation. In case of problems, get in touch with Salvatore Robuschi & C s.r.l. Technical Dept.
4	Check the distance between the two half-couplings is 3÷ 5 mm
5	Tighten the motor fixing bolts

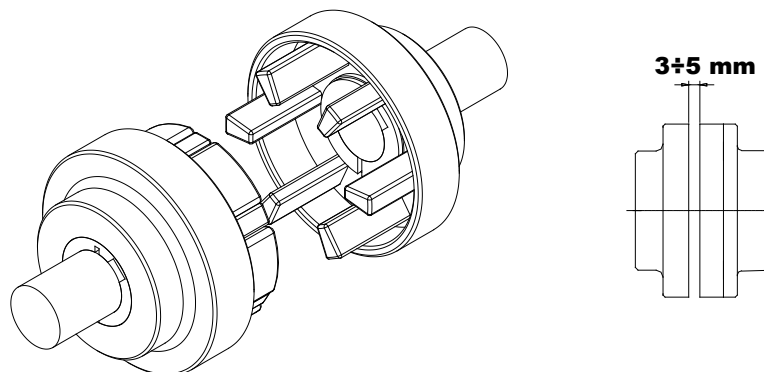

## 7.7. PUMP START



**FORBIDDEN!**  
The pump must never run dry.

Maximum power allowed for direct start-up (for data not in the table, start with star-delta, soft-start or with inverter).

Poles / rpm	Power (kW)
2P / 3000 rpm	Up to 30
4P / 1500 rpm	Up to 15
6P / 1000 rpm	Up to 11

To start the pump, proceed as described:

STEP	ACTION
1	Open the suction valve slightly (20% opening).
2	Start the pump.
3	When the motor has reached full throttle, slowly open the discharge valve and adjust the operating point.
4	Check that the current absorbed at full speed does not exceed the rated current.
5	Check that the work head is not lower than the curve bottom.

Number of start-ups allowed:

Motor power (kW)	max no. start-ups per hour
Up to 7.5	15
Up to 30	12
Over 30	10

### 7.7.1. CHECKS AFTER START-UP

To check after start-up, proceed as described below:

STEP	ACTION
1	Check that the pump turns in the indicated rotation direction.
2	Check that there is no excessive noise or vibration indicating a malfunction
3	Check that there are no leaks from the connections between the flanges and pipes.

## 7.8. STOP

If the system is equipped with non-return valves to stop the pump it is sufficient to stop the motor.

If the non-return valves are not present, stop the motor and close the discharge valve to prevent the reverse rotation of the pump for a long time.

Subsequently and independently of the aforementioned conformation:

STEP	ACTION
1	Close the auxiliary liquid valves (if present).
2	In case of shutdown with temperatures that could freeze the flushing liquid, drain the flushing pipes.

For extended stops, see the paragraph "EXTENDED STOPS"

## 7.9. EXTENDED STOPS

In the event of extended stops, the pump must be started for a few minutes at least once a month.

In case this is not possible, before the restart of the pump verify / check that:

- inside there are no incrustations or deposits that could obstruct the impeller and / or prevent its free rotation;
- the condition of the impeller, the tightening of the ogive, that there is not excessive and non-uniform wear of the blades at the inlet and outlet and, where present, of the ring or wear plate;
- the correct tightening of the casing, bearing housing and columns screws (APPENDIX B);
- all the checks and inspections contained in the "CHECKS AND MAINTENANCE" chapter.

If the pump is removed from the system, proceed with the instructions in the "STORAGE" section after having fully cleaned and dried the hydraulics and all the components in contact with the pumped fluid.

## 8. CHECKS AND MAINTENANCE



### CAUTION!

The maintenance operations must be carried out by qualified and authorised personnel.



### CAUTION!

Perform maintenance operations when the pump is off.

Risk		Description and procedural information
Danger of impact/tripping		Risk of impact and tripping on the edges of the machine structure. It is mandatory to wear appropriate PPE.
Danger of impact, dragging, crushing, shearing.		Danger of impact, dragging, crushing, shearing during maintenance stages. It is forbidden to access the moving parts of the pump during its operation. It is mandatory to wear appropriate PPE.
Danger of cutting/shearing.		Danger of cutting and shearing on moving machine parts during cleaning and maintenance stages. It is mandatory to wear appropriate PPE.
High-pressure fluid injection or ejection hazard		High-pressure fluid injection or ejection hazard during maintenance stages. It is mandatory to wear appropriate PPE.
Danger of burns and scalds		Danger of burns and scalds during cleaning and maintenance stages. Wait for the hot parts to cool down before proceeding. It is mandatory to wear appropriate PPE.
High voltage/electrocution hazard		Electrocution hazard during maintenance stages. It is forbidden to carry out work on electrical components without first switching-off the electrical power supply. It is mandatory to wear appropriate PPE.

### 8.1. SAFETY INFORMATION FOR CHECKS AND MAINTENANCE

The following information is to be considered supplementary to the "SAFETY REQUIREMENTS" paragraph.



### CAUTION!

Disconnect the power supply before any installation, maintenance and disassembly, making sure that the lifesaving devices are operating correctly.



### CAUTION!

It is necessary that the maintenance operations are carried out by using suitable equipment and in rooms suitable for ensuring the maximum safety of the operators.



### FORBIDDEN!

It is forbidden to remove the guards of the coupling or of the rotating shafts and any other safety protection during operation of the machine. If the protections are removed for maintenance, inspection operations or machine stop, they must be restored correctly and in their entirety before starting up again.



### IMPORTANT!

Use only original or authorised spare parts from Salvatore Robuschi & C. S.r.l.

The use of any other non-foreseen or unauthorised spare part absolves Salvatore Robuschi & C. S.r.l. from any liability in case of damage and invalidates the pump warranty.

## 8.2. PERIODIC CHECKS



### CAUTION!

Disconnect the power supply before any installation, maintenance and disassembly work, and ensure it cannot be accidentally restored.



### IMPORTANT!

It is mandatory to periodically check that the electrical equipment or devices used for the on-board machine system are earthed and/or double-insulated by construction.

### 8.2.1. LUBRICATION



### CAUTION!

For lubrication operations, wear appropriate PPE (gloves, goggles and possibly clothing), depending on the safety data sheets of the products used.

#### 8.2.1.1. Lubrication with grease

Periodically, every 2500 hours of operation, replace the lubrication grease of the bearings.  
For grease lubrication, see Table 10 (Paragraph "LUBRICATION WITH GREASE").

### 8.2.2. FLUSHING

Consult APPENDIX A and check, depending on the version (see paragraph "PUMP IDENTIFICATION CODES"), that the flow rate, pressure, level and / or temperature are correct.

### 8.2.3. PERFORMANCE

Check periodically or after maintenance work and / or any changes to the layout of the system, that the pump performance is as defined in the pump datasheet and the performance curves of the same. (Also consult the Chapter "FEATURES").

### 8.2.4. MOTOR

Check that the power absorbed by the electric motor is within the plate limits.  
Periodically check the efficiency of the electrical protections and the integrity of the connections.

### 8.2.5. PROTECTIONS

Check periodically and after every maintenance operation that the protections are present and correctly fixed: coupling guard, seal guards and, where present, flange protections, pipes and any other element provided to guarantee the safety of the operators (See Paragraph "INSTALLATION OF PROTECTIONS").

### 8.2.6. MOUNTING CLEARANCE

#### 8.2.6.1. WEAR RING (FOR RB-RD PUMPS ONLY)

Check the wear ring conditions and its clearance periodically and/or in case of performance loss. Here below a chart showing the nominal values of the mounting clearance that are likely to increase of even 50% in case of long-term use of the pump. The possibility of effectively bearing this increase depends on the pumped liquid features and the running conditions. For higher wear levels it's recommended to replace the part.

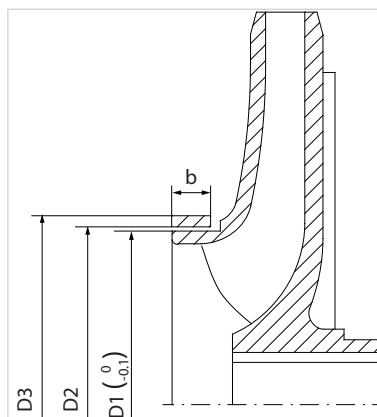

RB					
SIZE	D1 [mm]	D2 [mm]	D3 [mm]	b [mm]	CLEARANCE [mm]
65-20	94	95	104	13	1
80-20	119	120	128	18	1
80-25	119	120	128	18	1
100-25	144	145	155	18	1
125-25	169	170	180	20	1
80-31	124	125	135	20	1
125-31	169	170	180	20	1
150-31	209	210	220	20	1
125-40	169	170	180	20	1
150-35	209	210	220	20	1
200-35	229	230	240	20	1
250-35	259	260	275	20	1

RD					
SIZE	D1 [mm]	D2 [mm]	D3 [mm]	b [mm]	CLEARANCE [mm]
32-12, 32-16, 32-20	63.6	64	72	13	0.4÷0.5
40-12, 40-16, 40-20	73.6	74	82	13	0.4÷0.5
40-25, 50-12, 50-16, 50-20	89.6	90	98	13	0.4÷0.5
50-25, 65-16, 65-20, 65-25	114.6	115	123	16	0.4÷0.5
65-31, 80-16, 80-20, 80-25	129.5	130	138	16	0.5÷0.6
80-31, 80-40	139.5	140	150	18	0.5÷0.6
100-20, 100-25, 100-31, 100-40	154.5	155	165	18	0.5÷0.6
125-25, 125-31, 125-40	179.5	180	190	18	0.5÷0.6
100-31*	154	155	165	18	1
125-31*	179	180	190	18	1

\* Only for 2 Poles motor

### 8.2.6.2. WEAR PLATE (FOR RG-RE PUMPS ONLY)

Check the wear plate conditions and its clearance periodically and/or in case of performance loss. Here below a chart showing the nominal values of the mounting clearance. In case of replacement of the casing and/or the impeller, check that clearances are correct, otherwise adjust them again.

(For clearance adjustment see the Assembly and Disassembly manual)

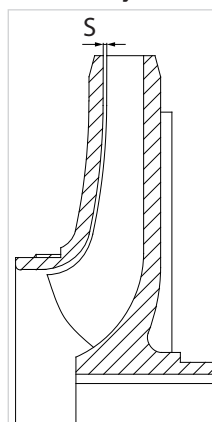

RG	
GRANDEZZA	GIOCO S [mm]
32-12, 32-16, 32-20, 40-12, 40-16, 40-20, 50-12, 50-16	0.4
65-16, 80-16, 50-20, 65-20	0.5

RG	
GRANDEZZA	GIOCO S [mm]
50-25, 80-20	0.65
65-25, 80-25, 80-31, 80-40, 100-20, 100-25, 100-31, 100-40, 125-25, 125-31, 125-40	0.8

  

RE	
GRANDEZZA	GIOCO S [mm]
ALL THE SIZE	0.8±1

### 8.2.7. BEARING BUSHES

Periodically verify the bearing bushes wear, particularly in presence of unusual vibrations and/or excessive noise. In order to guarantee that bearing bushes work properly, verify that the radial clearance P, between the shaft sleeve and the bearing bush, falls within the range of values shown in the chart below. If this value goes beyond the suggested limits, the bearing bush must be replaced.

ENGLISH

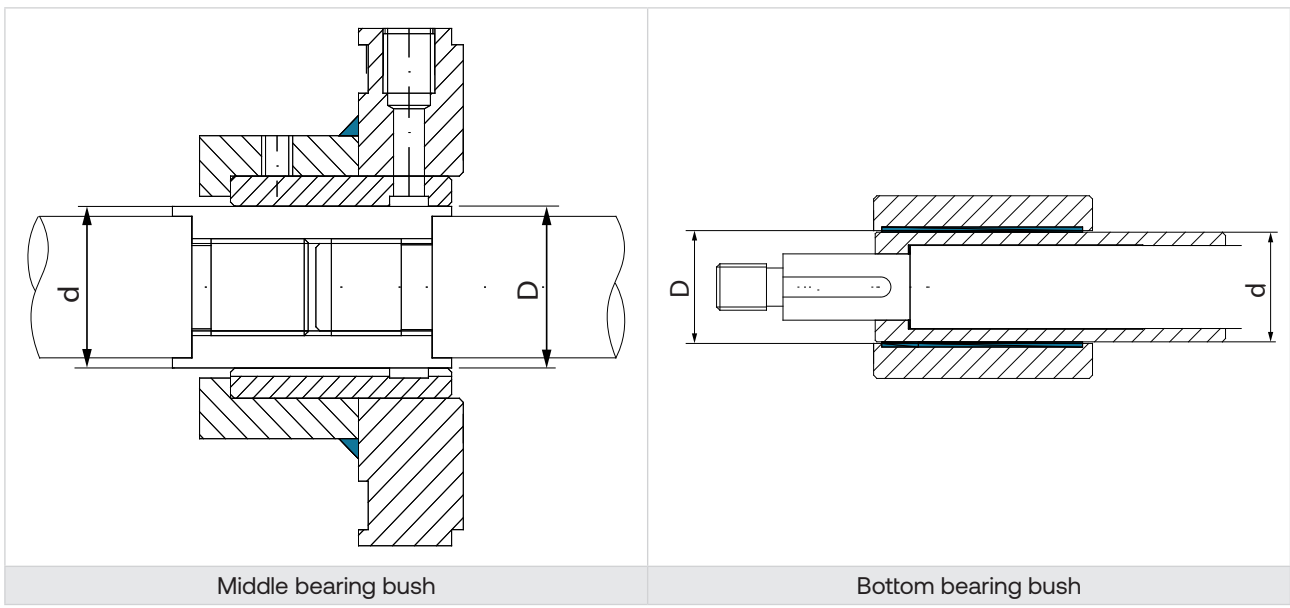

BEARING HOUSING	TYPE	d	P = D - d	CLEARANCE
1	Middle	40	0.15	0.1
	Bottom	33	0.15	0.1
2	Middle	45	0.15	0.1
	Bottom	43	0.15	0.1
3	Middle	60	0.2	0.1
	Bottom	53	0.2	0.1

Radial clearance values of bearing bushes

### 8.2.8. MECHANICAL SEAL

The mechanical seal does not require maintenance. Except for possible initial leaks after commissioning, the mechanical seal on the shaft must operate without leaks. **Avoid dry operation.** When a leak occurs which increases gradually, the seal must be replaced. Periodically check that the working conditions of the flushes (where present) correspond to that indicated in APPENDIX A.

### 8.2.9. COLUMN LEVEL

After any maintenance operation, check that the supporting column holes are not clogged (execution A and B) Check periodically and after every maintenance operation the correct level of medium in the column by the level rod (execution E).

### **8.2.10. SUCTION STRAINER AND FILTERS**

Check periodically that the solids and/or other foreign objects in the tank don't clog the filter holes. Reduction in the free suction surface may cause performance losses or damages to the pump.

### **8.2.11. INSTRUMENTATION AND AUXILIARY DEVICES**

Check the efficiency of the instrumentation (pressure gauges, etc.) and of the accessories necessary for the adjustment and proper operation of the pump.

## 9. DISASSEMBLY AND REASSEMBLY



**CAUTION!**

The disassembly and reassembly operations must be carried out by qualified and authorised personnel.



**CAUTION!**

Carry out the disassembly and reassembly when the pump is off.

Risk		Description and procedural information
Danger of crushing		Danger of crushing during movement of parts. It is mandatory to wear appropriate PPE.
High-pressure fluid injection or ejection hazard		High-pressure fluid injection or ejection hazard during disassembling stages. It is mandatory to wear appropriate PPE.
Danger of burns and scalds		Danger of burns and scalds during cleaning and maintenance stages. Wait for the hot parts to cool down before proceeding. It is mandatory to wear appropriate PPE.
High voltage/electrocution hazard		Electrocution hazard during disassembling stages. It is forbidden to carry out work on electrical components without first switching-off the electrical power supply. It is mandatory to wear appropriate PPE.

ENGLISH

### 9.1. SAFETY INFORMATION FOR DISASSEMBLY AND REASSEMBLY

The following information is to be considered supplementary to the "SAFETY REQUIREMENTS" paragraph.



**CAUTION!**

Disconnect the power supply before any installation, maintenance and disassembly, making sure that the lifesaving devices are operating correctly.



**CAUTION!**

It is necessary that the disassembly and reassembly are carried out by using suitable equipment and in rooms suitable for ensuring the maximum safety of the operators.

## 9.2. PRELIMINARY OPERATIONS



### CAUTION!

Disconnect the power supply before any installation, maintenance and disassembly work, and ensure it cannot be accidentally restored.

- Check that the pump is off.
- The pump casing and pipes must be cooled to room temperature.
- Close the system valves to isolate the pump.
- Close all the valves of the flushes and other auxiliary fluids.
- If the valves are out of use or not present, inform the safety officer and define a suitable intervention procedure. Then empty the system and the auxiliary circuits.
- If the pump works with dangerous liquids or which pose a health risk, decontaminate and clean the pump and the room in which it is located.
- Make sure that the pressure inside the pump casing and the auxiliary circuits is atmospheric. If it is higher, pay attention to the opening of the caps, fittings or flanges because the liquid will come out with force causing jets. Always open slowly, carefully and protect yourself to prevent contact with the liquid.

### 9.2.1. DISCONNECTION

- Remove the screws from the flanges or the connections to the pipes.
- Remove all the flushing connections and the auxiliary pipes, classifying them to reposition them correctly when reassembling the pump.

### 9.2.2. DRAIN AND RECLAMATION

When lifting the pump, its drainage happens spontaneously. Nevertheless, some residual fluids can be present inside the supporting column. In presence of toxic, harmful or dangerous substances, work with appropriate clothing and equipment in agreement with the safety officer and direct the fluids toward a safe area to avoid harming people or damaging things and environment.

- **VERSION A:** (holes on the bottom of the column): follow previous instructions
- **VERSION B:** remove and empty the flushing pipe, it can contain stagnation of pumped liquid
- **VERSION E:** empty the column through the pump-side plug; then lay it horizontally following instructions for VERSION A

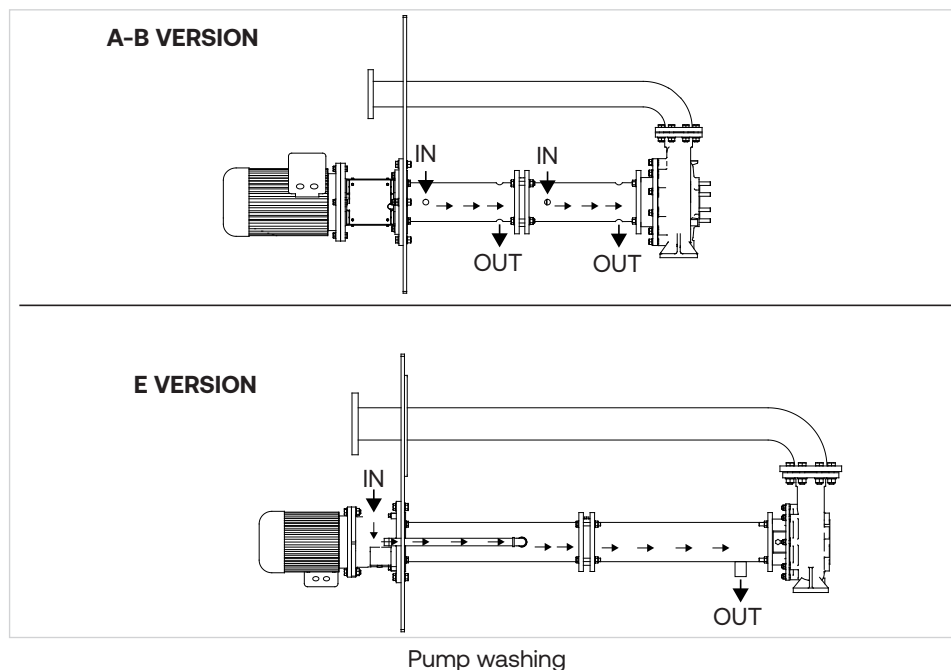

### 9.2.3. FINAL RECLAMATION

- Carefully remove any product residues present inside the pump and take all necessary measures for complete reclamation in accordance with the instructions of the safety officer.
- In the case of a pump with double seal: remove the liquid remaining inside the seal chamber.

### 9.3. INSTRUCTIONS FOR DISASSEMBLY AND REASSEMBLY OF THE PUMP

To disassemble and reassemble the pump, ask Salvatore Robuschi & C. S.r.l. for the dedicated manual, stating the model and serial number. **IT IS SPECIFICALLY PROHIBITED** to work on the pump without having this manual with you. In case of difficulties or doubts in understanding the instructions it is mandatory to suspend the intervention, secure the pump and the workplace and contact Salvatore Robuschi & C. S.r.l.

ENGLISH

## 10. SPARE PARTS

### 10.1. SPARE PARTS REQUEST, COMMISSIONING AND START-UP

To request spare parts, consult the pump sections on our general catalogue or on our website [www.salvatorerobuschi.com/Products](http://www.salvatorerobuschi.com/Products) and contact [ricambi@salvatorerobuschi.com](mailto:ricambi@salvatorerobuschi.com) stating the model, serial number and identification code of the desired components.

Use only original or authorised spare parts from Salvatore Robuschi & C. S.r.l.

The use of any other non-foreseen or unauthorised spare part absolves Salvatore Robuschi & C. S.r.l. from any liability in case of damage and invalidates the pump warranty.

### 10.2. SPARE PARTS AND SPARE PARTS SET FOR THE FIRST TWO YEARS OF USE (DIN 24296)

PART No.	DESCRIPTION	NUMBER OF PUMPS							
		1	2	3	4	5	From 6 to 7	From 8 to 9	10 and above
230	Impeller	1	1	1	1	2	2	2	20%
320.2	Ball bearing	1	1	2	2	2	3	3	25%
360.4	Spacer ball bearing	1	1	2	2	2	3	3	25%
400.1	Hydraulic gasket (Set)	1	1	2	2	3	3	4	50%
400.4									
420.1	Bearing cover seals(Set)	1	1	2	2	2	3	3	25%
420.2									
502.1 / 135	Wear ring / Wear plate	1	1	1	1	2	2	2	20%
524	Shaft sleeve	1	2	2	2	3	3	4	50%
545.1 / 545.3	Bottom bearing bush	1	1	2	2	3	3	4	50%
545.2	Middle bearing bush (if present)	1	1	2	2	3	3	4	50%
852	Coupling (if present)	1	1	2	2	3	3	4	50%
861.3	Coupling elastomers (Set)	1	2	2	2	3	3	4	40%
<b>PUMPS WITH MECHANICAL SEALS</b>									
433.2	Complete Mechanical Seal (Set) (if present)	1	1	2	2	3	3	4	50%

Table 13 - Spare parts set for the first two years of use

### 10.3. START UP SPARE PARTS AND SPARE PARTS SET

PART No.	DESCRIPTION	NUMBER OF PUMPS							
		1	2	3	4	5	From 6 to 7	From 8 to 9	10 and above
320.2	Ball bearing	1	1	1	1	1	2	2	10%
420.1	Bearing cover seals (Set)	1	1	1	1	1	2	2	10%
420.2									
400.1	Hydraulic gasket (Set)	1	1	1	1	1	2	2	20%
400.4									
524	Shaft sleeve	1	1	1	1	1	2	2	20%
545.1/ 545.3	Bottom bearing bush	1	1	1	1	1	2	2	10%
861.3	Coupling elastomers (Set)	1	1	2	2	2	3	3	30%
<b>PUMPS WITH MECHANICAL SEALS</b>									
433.2	Complete Mechanical Seal (Set) (if present)	1	1	2	2	2	3	3	30%

Table 14 – Start-up Spare parts set

## 11. SHIPPING TO SUPPLIER

Before returning the pump to the supplier, follow the steps below:

STEP	ACTION
1	Perform the steps indicated in the chapter "DISASSEMBLY AND REASSEMBLY".
2	It is mandatory to send a signed declaration that reclamation of the pump has taken place. The customer is responsible for any damage to property or persons due to residues not removed. It is also mandatory to indicate the possible presence of residual risks and the appropriate precautions to be taken in carrying out maintenance.
3	Pack the pump properly and correctly.

## 12. END OF LIFE AND DISPOSAL

This product falls within the scope of the Directive 2012/19/EU concerning the management of waste electrical and electronic equipment (WEEE).

The appliance must not be disposed of with domestic waste as it is made of different materials that can be recycled at the appropriate facilities. Ask through the municipal authority regarding the location of the ecological platforms to receive the product for disposal and its subsequent correct recycling.

Furthermore, upon purchase of an equivalent appliance, the distributor is obliged to collect the product for disposal free of charge.

The product is not potentially dangerous for human health and the environment, not containing harmful substances as per Directive 2011/65/EU (RoHS), but if released into the environment it negatively impacts the ecosystem.

Read the instructions carefully before using the appliance for the first time.

It is recommended that you do not use the product for any purpose other than that for which it was intended, there being a danger of electric shock if used improperly.



The crossed-out bin symbol, on the label on the appliance, indicates the compliance of this product with the regulations regarding waste electrical and electronic equipment.

Releasing the equipment into the environment or illegal disposal of the equipment is punishable by law.

ENGLISH

## 13. APPENDIX A – AUXILIARY CONNECTIONS AND SEAL FLUSHING

### 13.1. SEAL EXECUTION IDENTIFICATION

To identify the type of seal, see the paragraph "PUMP IDENTIFICATION CODE". The version is the one corresponding to point 6.

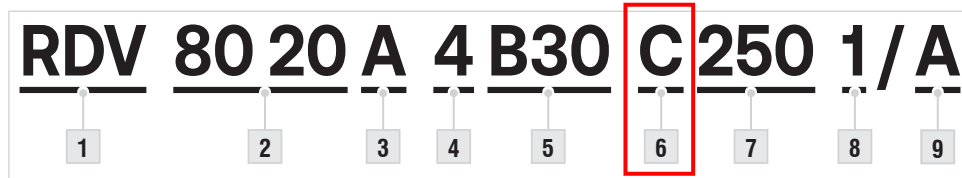

### 13.2. NAME

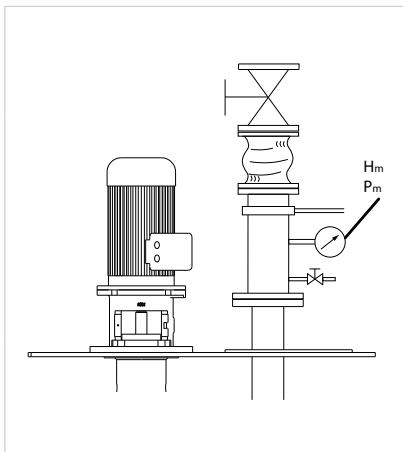

$\rho$  = Fluid density [kg/dm<sup>3</sup>]

$P_m$  = Discharge pressure [bar]

$H_m$  = Discharge head [m]

$H_m \approx (10 \cdot P_m) / \rho$

### 13.3. AUXILIARY CONNECTIONS AND BUSHES/SEAL FLUSHING

#### (A Exec.) Lubrication through process medium.

Intermediate bearing bushes lubrication through process medium recirculating from the discharge pipe. Lubrication of the bottom bearing bush is guaranteed by the minimum submergence of the pump (see the paragraph CHECK OF THE MEDIUM LEVEL IN THE TANK)

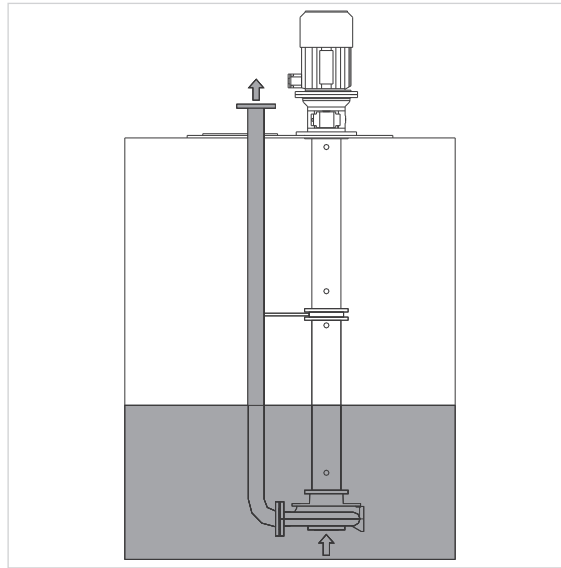

#### (B Exec.) Lubrication through a dedicated line, externally fed.

Connect the bearing bushes (bottom and intermediate) lubrication pipes to an external line and flush them through clean water at room temperature or through a medium compatible with the bearing bushes material and the process medium. Flushing pressure must be:

$$P_f = P_m/3 + 1\text{bar}$$

Flushing medium will dissolve into the tank.

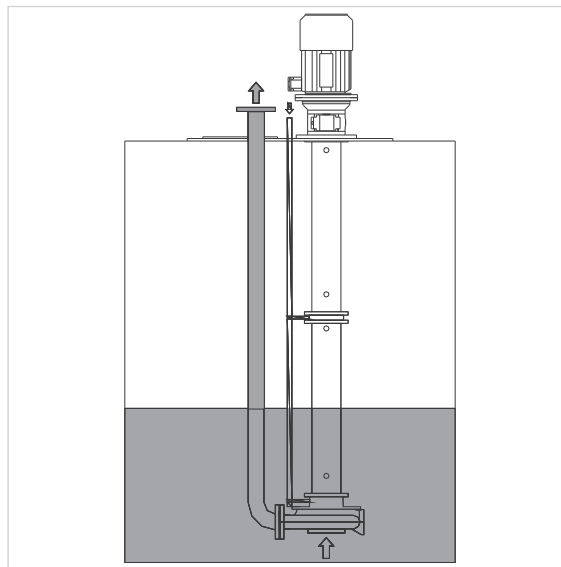

**(E Exec.) Lubrication through the medium in the column**

Fill the column with clean water + 30% of glycol and check the medium level by the appropriate level rod (and/or sensor).  
The mechanical seal is lubricated by the process medium and by the medium in the column pump  
(see the paragraph CHECK OF THE MEDIUM LEVEL IN THE TANK).

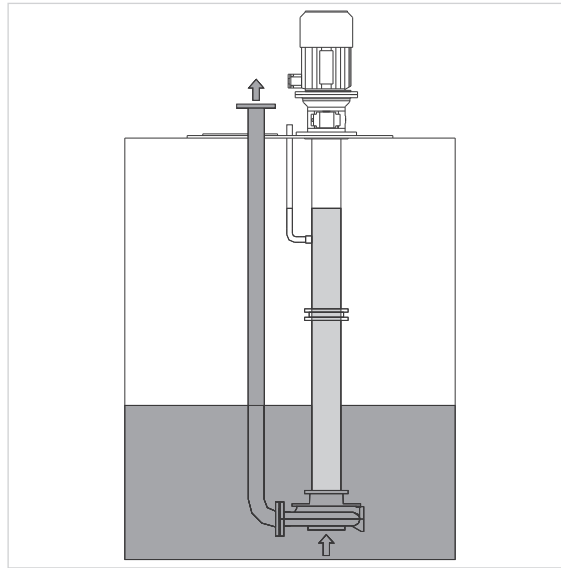

ENGLISH

## 14. APPENDIX B

TIGHTENING TORQUES TABLE	
Ø THREAD	TIGHTENING TORQUE (Nm)
M 5	5.5
M 6	9.5
M 8	23
M 10	46
M 12	79
M 14	127
M 16	198
M 18	283
M 20	402
M 22	552
M 24	691

Table 15 – Screw tightening torques

## 15. APPENDIX C

### 15.1. ADDENDUM FOR PARTLY COMPLETED MACHINERY ACCORDING TO DIRECTIVE 2006/42/EC

Pump type:-----

Serial number:-----

**Purpose:** This document describes the particular criteria for installation and coupling to a motor part that must be adopted for the correct operation of the pump (s) in question, as well as the main safety provisions to be complied with to avoid damage to property and / or persons during operation of the pump (s).

#### 15.1.1. CONNECTION TO A MOTOR PART BY FLEXIBLE COUPLING

If you intend to couple the pump to a standardised electric motor using a flexible coupling, consult the "Use and Maintenance Manual" supplied with the pump and the "Assembly and Disassembly" manual available on the website "[www.salvatorerobuschi.com](http://www.salvatorerobuschi.com)", which outlines the main provisions to be complied with in order to carry out a correct coupling.

The pump can be supplied with a standard joint cover, designed to prevent operators from accidentally coming into contact with the rotating parts during pump operation. Check, before starting the machine, that these joint covers are suitable for performing their protective function in light of the dimensional characteristics of the joint used.

If the dimensions of the installed joint do not allow the use of the standard joint cover supplied with the machine, or if the joint cover has not been supplied, it will be the responsibility of the user / installer to procure and install adequate protection to guarantee the safety of the operators present in the operating area of the pump and in compliance with the safety regulations in force.

Once the protection of the coupling parts has been installed, it is necessary to check that there is no sliding between the protection and the parts themselves in order to avoid overheating of the elements in question.

#### 15.1.2. CONNECTION TO A MOTOR PART THROUGH A DIFFERENT TYPE OF COUPLING

If you intend to couple the pump to a generic motor unit or use a coupling device different from a flexible coupling, it is necessary to check the operating limits in the catalogue or in the process of the commercial offer and available on the "Use and Maintenance Manual" supplied with the pump. If necessary, contact the technical department.

If you intend to use a coupling method different from the one described above, you must consult the instruction manual supplied by the manufacturer of the coupling parts to verify the criteria for their use.

It is the responsibility of the user / installer to procure and install adequate protection to guarantee the safety of the operators present in the operating area of the pump and in compliance with the safety regulations in force.

Once the protection of the coupling parts has been installed, it is necessary to check that there is no sliding between the protection and the parts themselves in order to avoid overheating of the elements in question.

Anyone who installs the "partly completed machine" inside their own machine, connecting it to a motor part, is required to provide the end user with specific instructions on the operation of his product.



**CAUTION!**

**Periodically check the degree of wear of the coupling with respect to the criteria recommended by the manufacturer.**

### 15.1.3. CONNECTION TO A MOTOR PART OF OPERATING PUMPS CERTIFIED FOR OPERATION IN AREAS SUBJECT TO ATEX DIRECTIVE 2014/34/EU



If the machine covered by this document is operated in potentially explosive areas subject to the ATEX directive 2014/34/UE, the user / installer must verify the correctness of the certification supplied with the machine.

The user / installer must ensure that the motor part, the coupling parts and the protection systems, if not supplied together with the machine, are suitable and comply with the ATEX directive 2014/34/EU.

### 15.1.4. ANALYSIS OF RISKS RELATED TO COUPLING WITH A MOTOR PART

Hazard source	Potential risk	Cause of the risk	Corrective measures or applicable protections
Rotating mechanical parts	Operators injury	Contact between the rotating parts and the operators during machine operation.	Installation of adequate protections to cover the rotating parts and the coupling systems of the pump with the motor element.
Rotating mechanical parts	Operators injury	Projection of components due to the breaking of the rotating elements or of the coupling parts.	Installation of adequate protections to cover the rotating parts and the coupling systems of the pump with the motor element.
Hot surfaces	Risk of burns	Friction between the rotating parts and the installed protections.	Check that the protections installed are adequate for the dimensions of the coupling parts. Periodically check that no modifications of the couplings or protections have occurred such as to cause these elements to come into contact.

## 15.2. DECLARATION OF INCORPORATION

We, Salvatore Robuschi & C. S.r.l., declare under our sole responsibility that the aforementioned pump (s) comply with the requirements of the 2006/42/EC, when used in compliance with the instructions contained in the instructions manual.

We also declare that the technical documentation concerning essential safety requirements of the pump has been compiled in compliance with the requirements of the 2006/42/EC Annex VII B.

We also undertake to transmit information on the aforementioned machine (s) to the national authorities, should there be any requests, as quickly as possible, by ordinary or electronic mail.

Salvatore Robuschi & C. S.r.l. is the sole party liable to compile the technical documentation relevant to the machine, should there be the need.

The partly completed machinery must not be put into service until the final machinery, into which it is to be incorporated, has been declared in conformity with the Directive 2006/42/EC

Date and Place

The Administrator Mr.